

INDEX



THE LIFE COMPANY
Introduction



PLUS
Automation
for up-and-over doors
Page 63



OPTIMO
Automation for
swing gates
Page 11



VIS
Automation
for industrial doors
Page 71



ARMOR
Automation for
swing gates
Page 21



SINUO DOOR
Automation
for book doors
Page 77



SINUO
Automation for
swing gates
Page 29



TENAX
Automation
For rolling shutter
Page 83



ERGO
Automation for
swing gates
Page 35



GEBOX
Control Units
Page 89



ACER
Automation for
sliding gates
Page 41



**VIPR - OMNIS - VIP - FIDO
STAR - BRAVO - EVER - BSM**
Remote Control Systems
Page 95

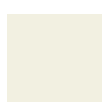

SUPRA
Automation for
crossing barriers
Page 51



**DES - DESE - DIXES
VISIO - VIRE - REX**
Photocells and Selectors
with supports and columns
Page 113



PROBO
Automation for sectional
and up and over doors
Page 57



SPLENDOR - FULGOR
Signalling and lighting systems
Page 123



To be part of a large group
To pursue great targets
To work closely in touch with the client
To always dream of new solutions



Abandoning the old
To understand and interpret the product
To trespass into unreal in order to create reality
Pleasure and beauty

DIGITAL LIFE

TECHNOLOGY

Professional

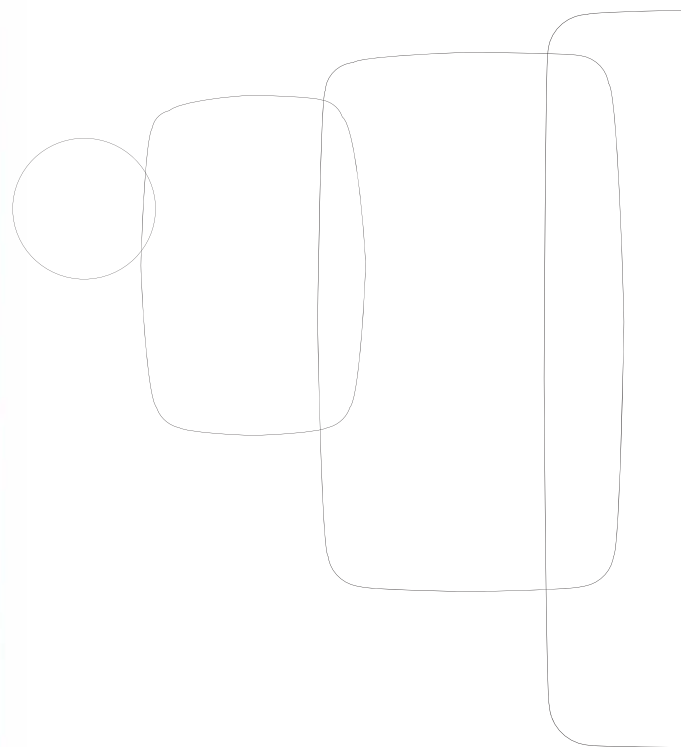
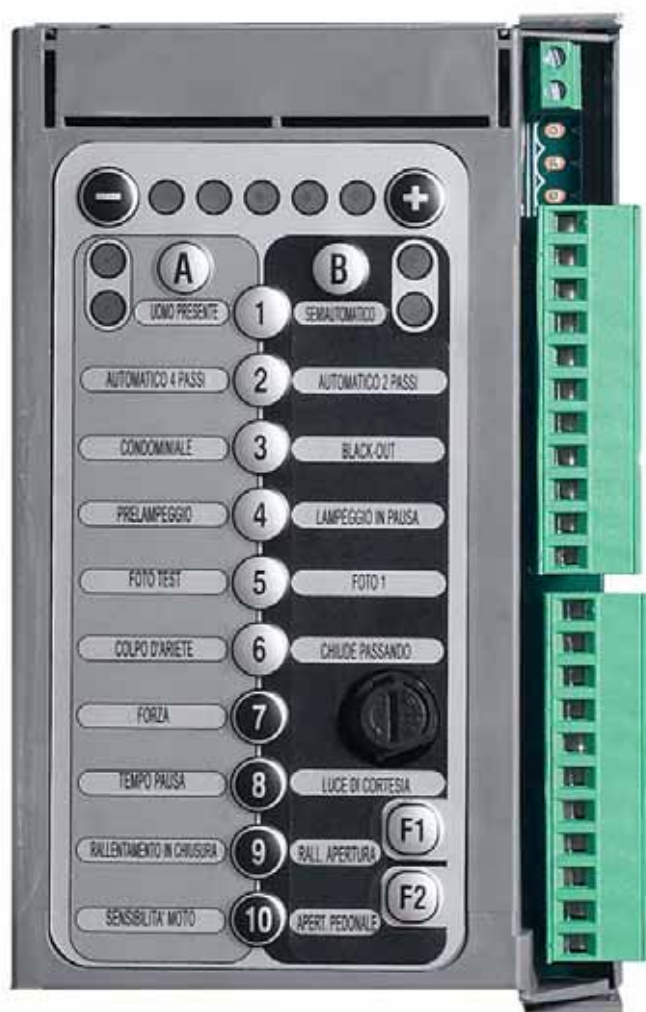

EVOLUTION GOES ON



Easy



LIFE welcomes you to the new automation generation with **DIGITAL LIFE TECHNOLOGY**. **LIFE** is avant-garde for domestic automation, not only with its new range of motors, but most of all due to its new concept of “home integration”. Throughout this technology even the most complex installations become quick and easy to carry out – the networking connection of the smart devices of the **DIGITAL LIFE TECHNOLOGY** range allows rapidity and cable precision, which leads to significant error reduction, higher security and faster performance. **DIGITAL LIFE TECHNOLOGY** means versatility and flexibility. The developed software protocol allows an efficient and quick dialogue between the control unit microprocessor and each of the microprocessors located in the smart applications. From now on, with **DIGITAL LIFE TECHNOLOGY** you can program, by just pushing one button, even the most complicated structure of photocells, control units and boards. **DIGITAL LIFE TECHNOLOGY** is, literally, simplicity at your fingertips: a complete and intuitive programming keyboard, coloured and lit signalling led...in the end, choosing **DIGITAL LIFE TECHNOLOGY** means to have an easy and very smart instrument, one that always has an answer and a solution.

LIF



STYLE AND ELEGANCE



SINUO

The password is security thanks to the well planned devices. Everything is created to give balance and precision. Sinuo is a tireless motor, powerfull and simple to manage. Protected from collisions by a plastic cover that makes it pliable in the design.

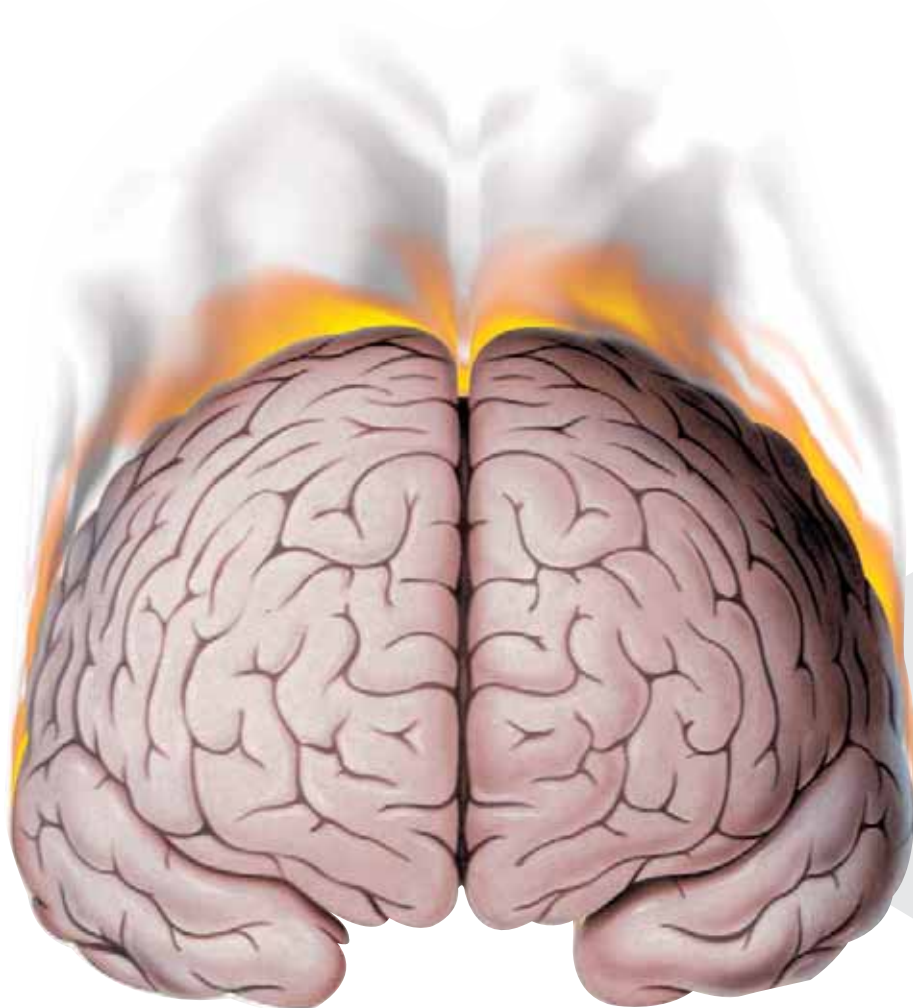

“...all begins with the irrational,
controlled by the brain’s right hemisphere:
here thoughts and ideas are born and develop,
until the turmoil they cause reaches
the soul and here they explode into...”

E *design*



...the copywriter control the explosions.

OPTIMO

Automation for swing gates

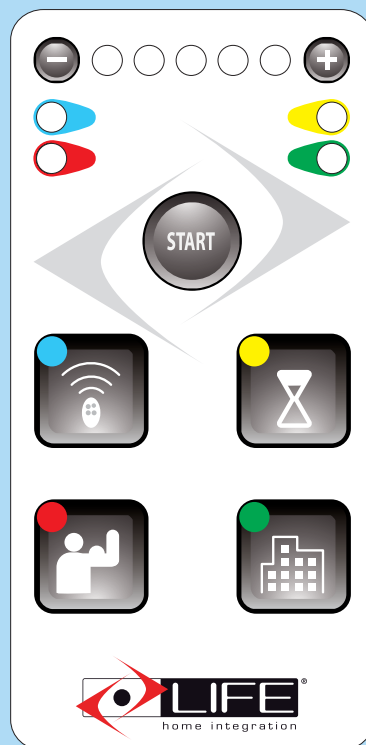



Automation for
swing gates





OPTIMO Automation for swing gates



Automation for swing gates

LIFE inaugurates new perspectives in the world of automation, even in the field of swing gate motors. The **Optimo** range of linear electromechanical actuators offers a wide range of choice between the 230 V and 24 V versions, with slow or fast movement. This is partnered by a high level of design and manufacturing, in line with the most evolved quality, design and functional standards on the market. There is more... discover for yourself all the advantages of this and other **LIFE** products and open up to a new era in "home integration".

Instant safety

Optimo has a vigilant eye and a quick brain, namely the optical "encoder", the electronic control unit and the limit switches. The encoder keeps the gate operating under control and instantly detects any object or person that should suddenly invade its operative area. The electronic control unit processes all information and activates the most appropriate safety measures in real time. As safety can never be too much, **Optimo** is also fitted with two "limit switch" devices that send a further precise signal of the gate position.



Protection in every season

The release mechanism is perfectly sheltered from water, and other agents' infiltration. Though its use is rarely required, the release mechanism has been designed to be activated with ease, quickness and safety, offering extra convenience.

Cleverly arranged

The **Optimo** gear motor is already equipped with a power cable and a signalling cable, both one meter long, to make electrical connections simpler and quicker: moreover, it also comes with an internal cabling system which facilitates maintenance. The assembling brackets are solid, modular and smart, ideal for solving any installation requirement.

Mounting instructions are clear, simple and intuitive, assisting the installer through all stages of his work. **LIFE** has designed everything to the finest detail, including a charming design and a range of customized services.

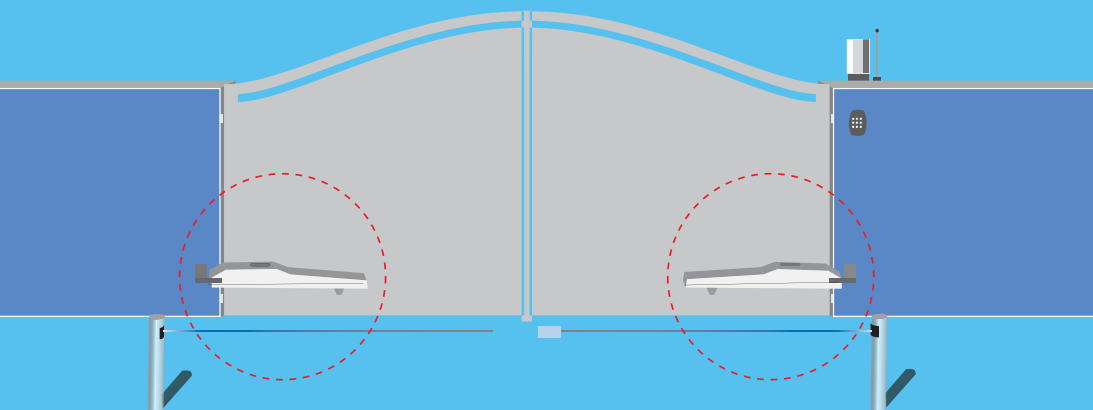

Max weight wing (see graphic)	kg
Max length wing (see graphic)	m
Motor supply	V
Power supply	W
Power	N
Working stroke	mm
Working temperature	°C Min/Max
Protection level	IP
Intermittence work cycle	%
Time for 90° cycle	s

OPTIMO

Ω	OP2 24 UNI			OP SL UNI			OP3 - OP3L - OP3 UNI OP3L UNI - OP3 24 OP3 24 UNI			OP5 - OP5L - OP5 UNI OP5L UNI - OP5 24 OP5 24 UNI		
	A max mm	B max mm	D max mm	A max mm	B max mm	D max mm	A max mm	B max mm	D max mm	A max mm	B max mm	D max mm
$\Omega_1 = 90^\circ$	160	160	640	160	160	720	140	140	755	210	210	905
$\Omega_1 = 120^\circ$	130	120	640	145	120	720	140	100	755	210	120	905

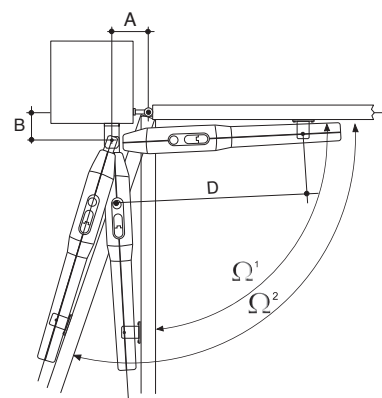
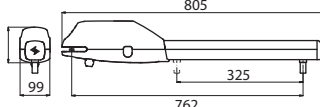
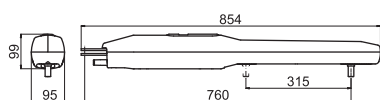
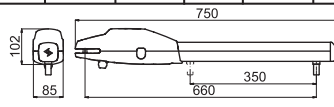
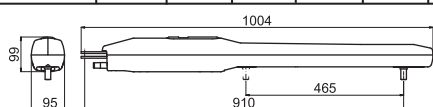

Code	Wing	Motor	Description	Pcs / Pallet	€ / Pcs
OP2 24 UNI	2,30 m	24V d.c. Intensive Use	Version equipped with mechanical open/close stopping	20	229,00
OP3 24	3 m	24V d.c. Intensive Use	Irreversible motor equipped with encoder, limit switches in opening and closing, cased in alu box and 1 mt. long pre-cabled wires.	20	379,00
OP3	3 m	230V a.c.	Fast irreversible motor equipped with encoder, limit switches in opening and closing, cased in alu box and 1 mt. long pre-cabled wires. Capacitor supplied.	20	359,00
OP3 UNI	3 m	230V a.c.	Fast version equipped with mechanical open/close stopping. Capacitor supplied. 1 mt. long pre-cable wires.	20	319,00
OP3 UNI L	3 m	230V a.c.	Slow version equipped with mechanical open/close stopping 1 mt. long pre-cables wire. Capacitor supplied. 1 mt. long pre-cabled wires.	20	319,00
OP5 24	5 m	24V d.c. Intensive Use	Irreversible motor equipped with encoder, limit switches in opening and closing, cased in alu box and 1 mt. long pre-cabled wires.	20	439,00
OP5	5 m	230V a.c.	Fast irreversible motor equipped with encoder, limit switches in opening and closing, cased in alu box and 1 mt. long pre-cabled wires. Capacitor supplied.	20	409,00
OP5 UNI	5 m	230V a.c.	Fast version equipped with mechanical open/close stopping 1 mt. long pre-cables wire. Capacitor supplied.	20	369,00
OP5 UNI L	5 m	230V a.c.	Slow version equipped with mechanical open/close stopping Capacitor supplied. 1 mt. long pre-cabled wires.	20	369,00
OP3 SL SKY LINE UNI	3 m	230V a.c.	Version equipped with mechanical open/close stopping. Capacitor supplied.	20	279,00

230V 50Hz					24V		
OP3 UNI	OP3L	OP3 SL UNI	OP5 UNI	OP5L	OP2 24 UNI	OP3 24	OP5 24
800	800	350	900	900	250	800	900
3	3	3	5	5	2,30	3	5
230V a.c.	230V a.c.	230V a.c.	230V a.c.	230V a.c.	24V d.c.	24V d.c.	24V d.c.
210	220	160	210	220	60	80	80
2000	2000	1800	2000	2000	1500	1800	1800
315	315	325	465	465	350	315	465
-20 +70	-20 +70	-20 +70	-20 +70	-20 +70	-20 +70	-20 +70	-20 +70
54	54	54	54	54	54	54	54
35	30	35	35	30	80	80	80
19	30	19	28	45	15	19	28

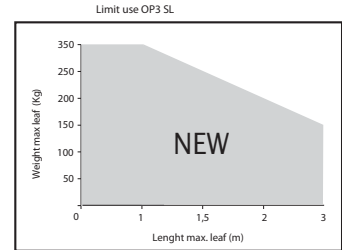
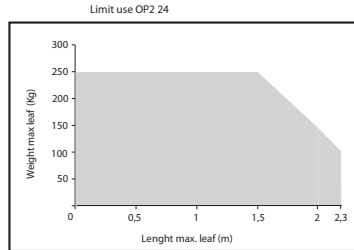
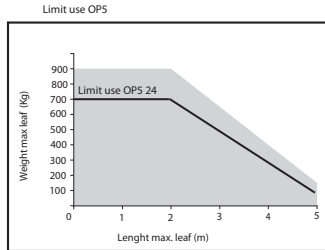
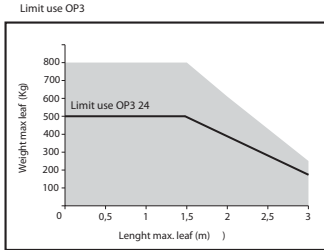

Reduce Limit use in case of windy area, or particular structural shape of the gate.

AOP1 € / Pcs 34,00



Modular adjustable rear bracket.
(Kit/Box 2)

AOP2 € / Pcs 38,00



Modular adjustable front bracket.
(Kit/Box 2)

AELVE € / Pcs 159,00



Vertical electrolock.
(Pcs/Box 1) see N.B.

AELOR € / Pcs 159,00



Horizontal electrolock.
(Pcs/Box 1) see N.B.

TL € / Pcs 2,90



Warning sign

AGECH € / Pcs 49,00



Battery charger additional circuit
for control boards
(see table at page 94)
(Pcs/Box 1)

AGE12 € 120,00



Battery 12V - 2,3 Ah.
(Pcs/Box 2)

N.B.
For leaf over 3m and for leaf over 2m for OP2,
use of electrolock is recommended.

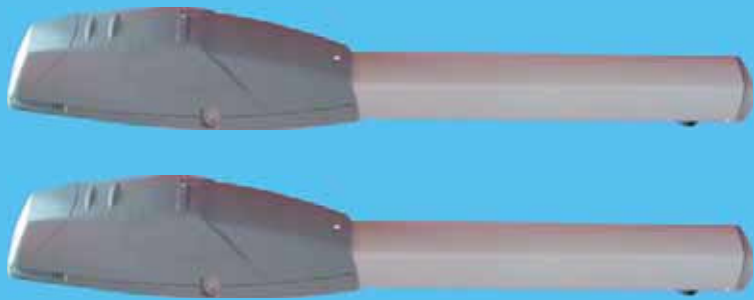

Full Setup 230V for gate automation - two swing gates up to 3 meters

SETUP OPTIMO SKY LINE



FID02
1 Transmitter
433,92 MHz
LIFE Rolling Code
Page 104



DES
1 Key selector
for external
use
Page 117



VISIO
1 External pair
of photocells
Page 121



SPL
1 Flashlight
Page 127



SKANX
1 Matching
antenna and
coaxial cable.
Page 127



GE UNI RS DL
1 Control unit
with receiver
integrated
Page 93



TL
1 Warning sign

Code	Wing	Gear motor	Setup / Pallet	€ / Setup
SETUP OP SL UNI	3 m	OP SL UNI	15	864,00



FID02
1 Transmitter
433,92 MHz
LIFE Rolling Code
Page 104



VISIO
1 External pair
of photocells
Page 121



SKANT
1 Matching
antenna and
coaxial cable.
Page 127



GE UNI RS DL
1 Control unit
with receiver
integrated
Page 93

Code	Wing	Gear motor	Setup / Pallet	€ / Setup
SETUP OP SL UNI S	3 m	OP SL UNI	15	809,00



FID02
1 Transmitter
433,92 MHz
LIFE Rolling Code
Page 104



GE UNI RS DL
1 Control unit
with radio and
receiver integrated
Page 93

Code	Wing	Gear motor	Setup / Pallet	€ / Setup
SETUP OP SL UNI EASY	3 m	OP SL UNI	15	763,00



Setup 230V 50 Hz for gate automation - two swing gates

SETUP OPTIMO OP3 UNI DL - OP5 UNI DL



FID02
1 Transmitter
433,92 MHz
LIFE Rolling Code
Page 104



DES
1 Key selector
for external
use
Page 117



VISIO
1 External pair
of photocells
Page 121



SPL
1 Flashlight
Page 127



SKANX
1 Matching
antenna and
coaxial cable.
Page 127



GE UNI RS DL
1 Control unit
with receiver
integrated
Page 93



TL
1 Warning sign

Code	Wing	Gear motor	Setup / Pallet	€ / Setup
SETUP OP3 UNI DL	3 m	OP3 UNI	15	939,00
SETUP OP5 UNI DL	5 m	OP5 UNI	15	1033,00



FID02
1 Transmitter
433,92 MHz
LIFE Rolling Code
Page 104



VISIO
1 External pair
of photocells
Page 121



SKANT
1 Matching
antenna and
coaxial cable.
Page 127



GE UNI RS DL
1 Control unit
with receiver
integrated
Page 93

Code	Wing	Gear motor	Setup / Pallet	€ / Setup
SETUP OP3 UNI DL S	3 m	OP3 UNI	15	884,00
SETUP OP5 UNI DL S	5 m	OP5 UNI	15	977,00



FID02
2 Transmitters
433,92 MHz
LIFE Rolling Code
Page 104



GE UNI RS DL
1 Control unit
with radio and
receiver integrated
Page 93

Code	Wing	Gear motor	Setup / Pallet	€ / Setup
SETUP OP3 UNI DL EASY	3 m	OP3 UNI	15	838,00
SETUP OP5 UNI DL EASY	5 m	OP5 UNI	15	932,00

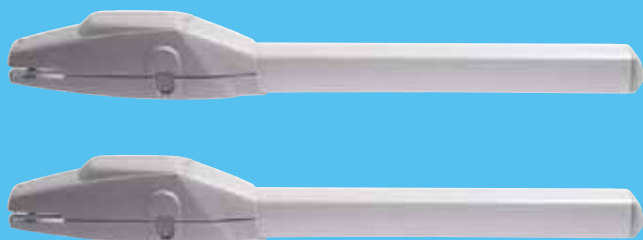

Full Setup 24V for gate automation - two swing gates u
to 2,3 meters

SETUP OPTIMO DL



FIDO2
1 Transmitter
433,92 MHz
LIFE Rolling Code
Page 104



DES
1 Key selector
for external
use
Page 117



VISIO
1 External pair
of photocells
Page 121



SPL 24
1 Flashlight
Page 127



SKANX
1 Matching
antenna and
coaxial cable.
Page 127



GE UNI 24R DL
1 Control unit
with receiver
integrated
Page 93



TL
1 Warning Sign.

Code	Wing	Gear motor	Setup / Pallet	€ / Setup
SETUP OP2 24 UNI DL	2,30 m	OP2 24 UNI	15	770,00



FIDO2
1 Transmitter
433,92 MHz
LIFE Rolling Code
Page 104



VISIO
1 External pair
of photocells
Page 121



SKANT
1 Matching
antenna and
coaxial cable.
Page 127



GE UNI 24R DL
1 Control unit
with receiver
integrated
Page 93

Code	Wing	Gear motor	Setup / Pallet	€ / Setup
SETUP OP2 24 UNI DL S	2,30 m	OP2 24 UNI	15	719,00



FIDO2
2 Transmitters
433,92 MHz
LIFE Rolling Code
Page 104



GE UNI 24R DL
1 Control unit
with receiver
integrated
Page 93

Code	Wing	Gear motor	Setup / Pallet	€ / Setup
SETUP OP2 24 UNI DL EASY	2,30 m	OP2 24 UNI	15	676,00



DIGITAL LIFE

TECHNOLOGY



SIMPLICITY
SPEED
RELIABILITY



Universal technology with a single finger

LIFE welcomes you to the new automation generation with **DIGITAL LIFE TECHNOLOGY**.

LIFE is avant-garde for domestic automation, not only with its new range of motors, but most of all due to its new concept of “home integration”. Throughout this technology even the most complex installations become quick and easy to carry out – the networking connection of the smart devices of the

DIGITAL LIFE TECHNOLOGY range allows rapidity and cable precision, which leads to significant error reduction, higher security and faster performance. **DIGITAL LIFE TECHNOLOGY** means versatility and flexibility. The developed software protocol allows an efficient and quick dialogue between the control unit microprocessor and each of the microprocessors located in the smart applications.

From now on, with **DIGITAL LIFE TECHNOLOGY** you can program, by just pushing one button, even the most complicated structure of photocells, control units and boards. **DIGITAL LIFE TECHNOLOGY** is, literally, simplicity at your fingertips: a complete and intuitive programming keyboard, coloured and lit signalling led...in the end, choosing **DIGITAL LIFE TECHNOLOGY** means to have an easy and very smart instrument, one that always has an answer and a solution.

ARMOR

Automation for swing gates

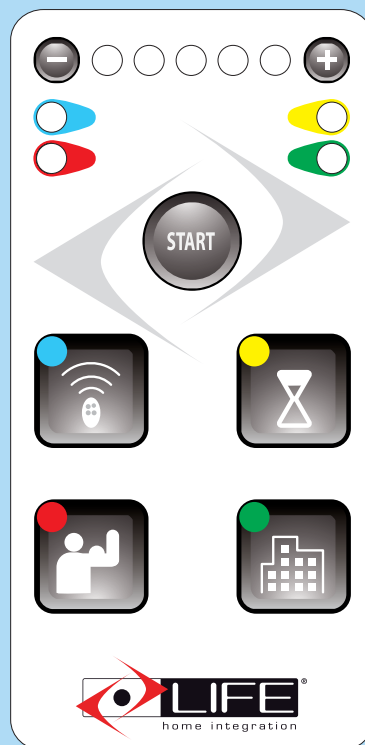





ARMOR

Automation for swing gates



Automation for swing gates

LIFE opens new perspectives in the world of automation: even for the swing gates sector. In fact, the family of electromechanical gear motor **Armor** offers a wide range of choice in the 24Vdc versions with DIGITAL LIFE TECHNOLOGY. This is the result of high level designing and manufacturing, aligned with the most evolved and demanding quality, design and functionality standards on the present market. But that's not all... find out all the benefits of this and the other **LIFE** products: open up to a new era in "home integration".

A novelty designed to last

Armor models are designed and manufactured without losing quality. The structure is made of a high density aluminium diecast, a material as light as inalterable. The external shell, one of **LIFE's** distinguishing features, is undeformable. Drive shaft and main machinery lie on oversized ball-bearings, bronze bushings and gauge, in order to guarantee the best resistance through time.



Instant safety

Armor has an alert eye and a clever brain: the encoder, the electronic control unit and the limit switches. The encoder monitors the gate's functioning and instantly detects any object or person that should cross its ray of action. The electronic control unit elaborates all the information and enables in real time the most appropriate safety measures. As safety is never too much, **Armor** also comes with two "limit switches" that send another precise signal about the gate's positioning.

Simple installation, immediate integration

DIGITAL LIFE TECHNOLOGY interface and protocol allow a simpler installation of photocells, transponder, digital selectors and other command devices. New devices are immediately acknowledged, due to the "plug and play" system: therefore the system can be updated and expanded at any time. You only need three steps to configure the installation: a clever instrument that always provides an answer to your installation and **LIFE's** quality, design and customized services you will reach the higher levels of technical satisfaction.

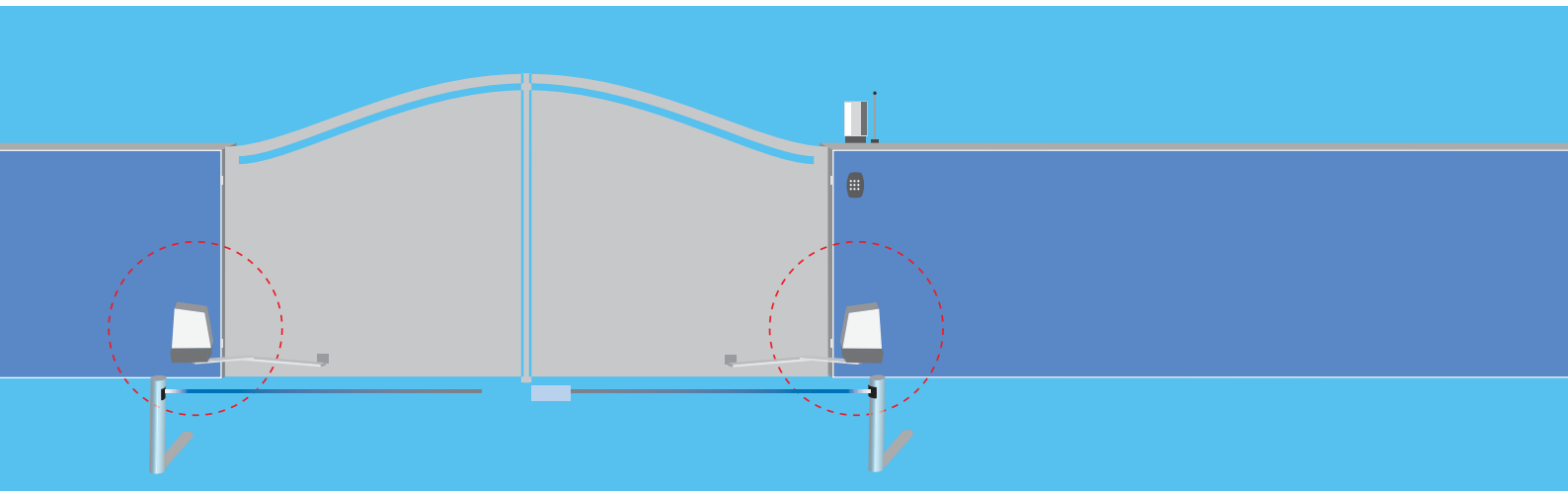

ARMOR

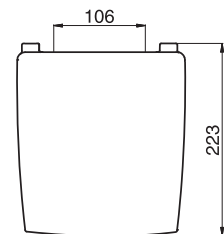
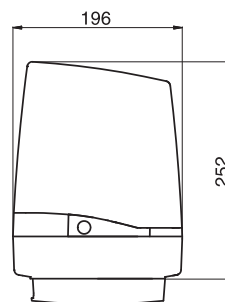
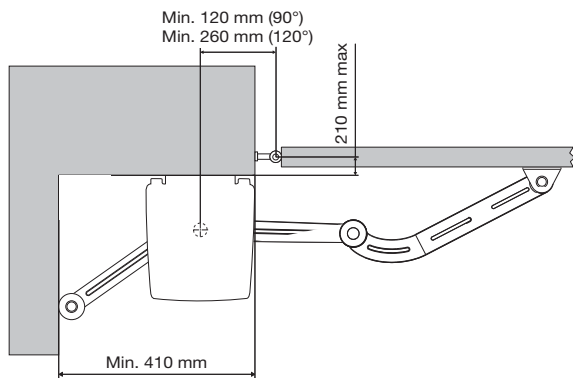

Electromechanical irreversible gear motor with articulated arm for swing gates. External mounting.

Code	Wing	Motor	Description	Pcs / Pallet	€ / Pcs
ARO 24 UNI	2,30 m	24V d.c.	Irreversible gear motor. Equipped with encoder, limit switches in opening and closing. Central unit not included.	16/24	339,00
AR2 24P UNI DL	2,30 m	24V d.c.	Irreversible gear motor. Equipped with Mechanical opening and closing stop system. Central unit (RG UNI 24R DL AR) for double motor with integrated 433,92 MHz LIFE rolling code radio receiver.	16/24	439,00



UNI: motor without encoder

		ARO 24 UNI	AR2 24P UNI DL
Max weight wing (see graphic)	kg	250	250
Max lenght wing (see graphic)	m	2,30	2,30
Power supply	V	230V 50 Hz	230V 50 Hz
Motor supply	V	24V d.c.	24V d.c.
Power	W	40	40
Pair	Nm	170	170
Working temperature	°C Min/Max	-20 +70	-20 +70
Protection level	IP	44	44
Intermittence work cycle	%	80	80
Time for 90° cycle	s	14	14

Limit use ARMOR

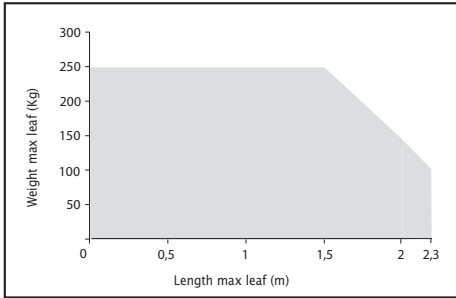

Reduce Limit use in case of windy area, or particular structural shape of the gate.

ARMAX € / Pcs 99,00Oversized articulated arm.
(Pcs/Box 1)**ASECAR** € / Pcs 29,00External unlocking device
with metallic cable.
(Pcs/Box 1)**DOS** € / Pcs 99,00Key selector to mechanically
release the lock.
(Pcs/Box 1)**AELVE** € / Pcs 159,00Vertical electrolock
(Pcs/Box 1)**AELOR** € / Pcs 159,00Horizontal electrolock.
(Pcs/Box 1)**AGECH** € / Pcs 49,00Battery charger additional circuit
for control boards
(see table at page 94)
(Pcs/Box 1)**AGE12** € / Pcs 120,00Battery 12V - 2,3 Ah.
(Pcs/Box 2)**TL** € / Pcs 2,90

Warning sign.



24 V complete Setup for swing gate automation with wing up to 2,3 mt.

SETUP ARMOR



FIDO2
1 Transmitter
433,92 MHz
LIFE Rolling Code
Page 104



DES
1 Key selector
for external
use
Page 117



VISIO
1 External pair
of photocells
Page 121



SPL24
1 Flashlight
Page 127



SKANX
1 Matching
antenna and
coaxial cable
Page 127



RG UNI 24 R DL AR
1 Control unit
with receiver
integrated.
Page 93



TL
1 Warning Sign

Code	Wing	Gear motor	Setup / Pallet	€ / Setup
SETUP ARMOR UNI DL	2,30 m	ARO 24 UNI e AR2 24P UNI DL	18	864,00



FIDO2
1 Transmitter
433,92 MHz
LIFE Rolling Code
Page 104



VISIO
1 External pair
of photocells
Page 121



SKANT
1 Matching
antenna and
coaxial cable
Page 127



RG UNI 24 R DL AR
1 Control unit
with receiver
integrated.
Page 93

Code	Wing	Gear motor	Setup / Pallet	€ / Setup
SETUP ARMOR UNI DL S	2,30 m	ARO 24 UNI e AR2 24P UNI DL	18	808,00



FIDO2
2 Transmitters
433,92 MHz
LIFE Rolling Code
Page 104



RG UNI 24 R DL AR
1 Control unit with
receiver and radio
integrated.
Page 93

Code	Wing	Gear motor	Setup / Pallet	€ / Setup
SETUP ARMOR UNI DL EASY	2,30 m	ARO 24 UNI e AR2 24P UNI DL	18	765,00



DIGITAL LIFE

TECHNOLOGY



SIMPLICITY
SPEED
RELIABILITY



Universal technology with a single finger

LIFE elcomes you to the new automation generation with **DIGITAL LIFE TECHNOLOGY**. **LIFE** is avant-garde for domestic automation, not only with its new range of motors, but most of all due to its new concept of “home integration”. Throughout this technology even the most complex installations become quick and easy to carry out – the networking connection of the smart devices of the **DIGITAL LIFE TECHNOLOGY** range allows rapidity and cable precision, which leads to significant error reduction, higher security and faster performance. **DIGITAL LIFE TECHNOLOGY** means versatility and flexibility. The developed software protocol allows an efficient and quick dialogue between the control unit microprocessor and each of the microprocessors located in the smart applications. From now on, with **DIGITAL LIFE TECHNOLOGY** you can program, by just pushing one button, even the most complicated structure of photocells, control units and boards. **DIGITAL LIFE TECHNOLOGY** is, literally, simplicity at your fingertips: a complete and intuitive programming keyboard, coloured and lit signalling led...in the end, choosing **DIGITAL LIFE TECHNOLOGY** means to have an easy and very smart instrument, one that always has an answer and a solution.

SINUO

Automaion for swing gate



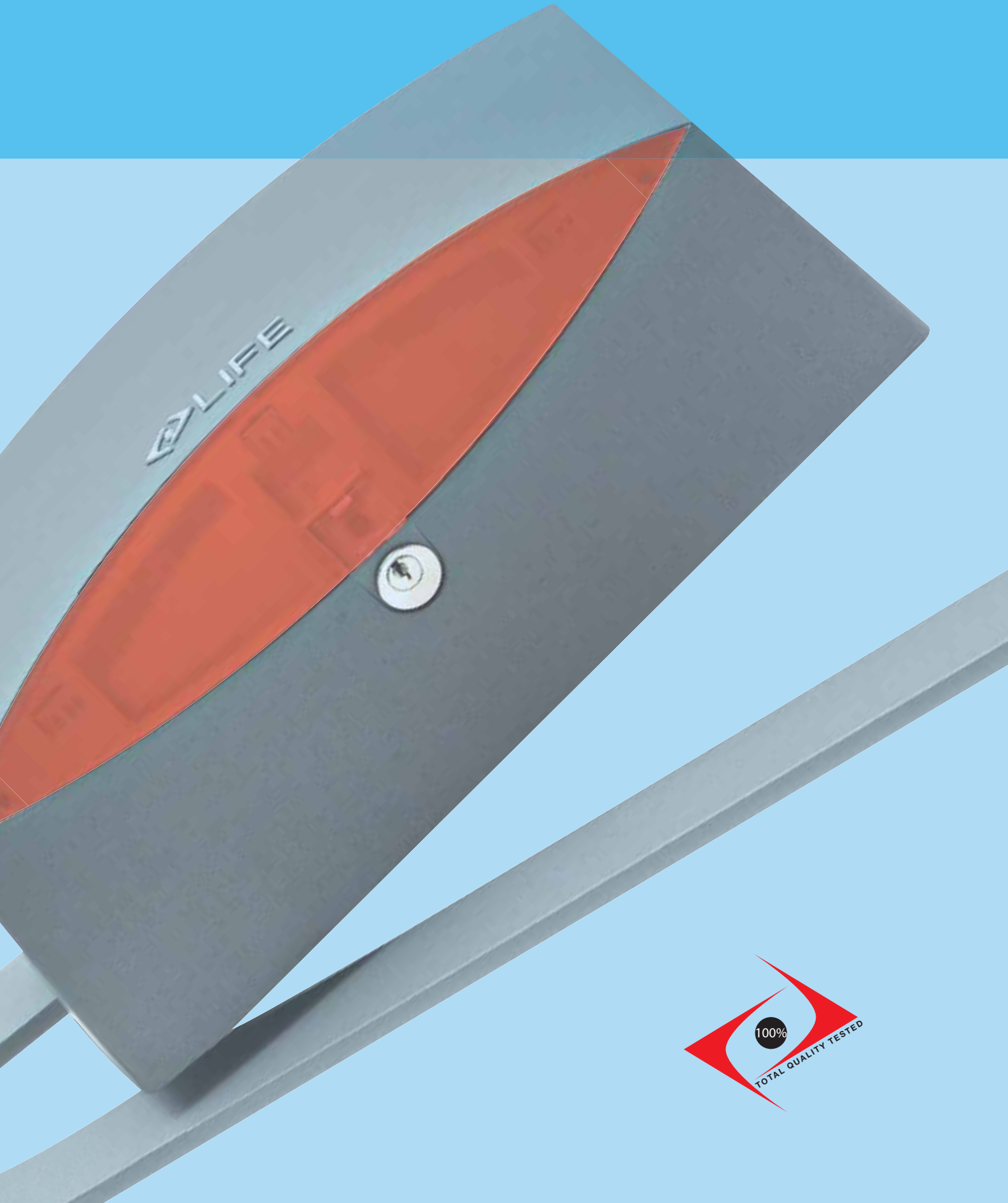



SINUO

Automation for swing gates



Automation for swing gates

Sinuo automation for Door up to 5 meters satisfies Every need. Proposed in version 230V to reach the highest security levels. It unifies the maximum of services and strength to a contemporary and nice design. In side of that there is an high level project and realisation, together with the more developed contemporary standards of quality and design and functionality.

Projected to last

Up to the firs project till the finished product, the **Sinuo** models are studied in the single details, to ensure you the best performances in the time.

The structure of two hulls in press fused in aluminium is the top of lightness and alterability. The correct thickness and the precise realisation of the hulls ensure a stability and strangeness able to overcame each type of test. Particular attention has been dedicate to the realisation of the reduction gear's mechanic, which permit a silent rotation.



Functionality first of all

LIFE fit ought to everything to improve the customer's life, and also to simplify the work of the installers and technicians. From the hull of protection extractable thanks to very simply accessible screws, up to the unblock system which is perfectly repaired by water's infiltrations soil and other extraneous bodies. Even if its use is rarely anticipated, the mechanical unblock system has been studied to be effectuated with the maximum facility and safety: one more convenience.

Simplicity first of all

LIFE knows the concrete demands of the installers, therefore it studied each detail to make simple, quick and gratifying their work.

The assembling instruction are clear and complete and follow step by step the operator. In this way it is possible to save time and work obtaining perfect results: another advantage of **LIFE**'s products.

Over a complete choice of solutions, there is also a range of personalized technical and commercial services.

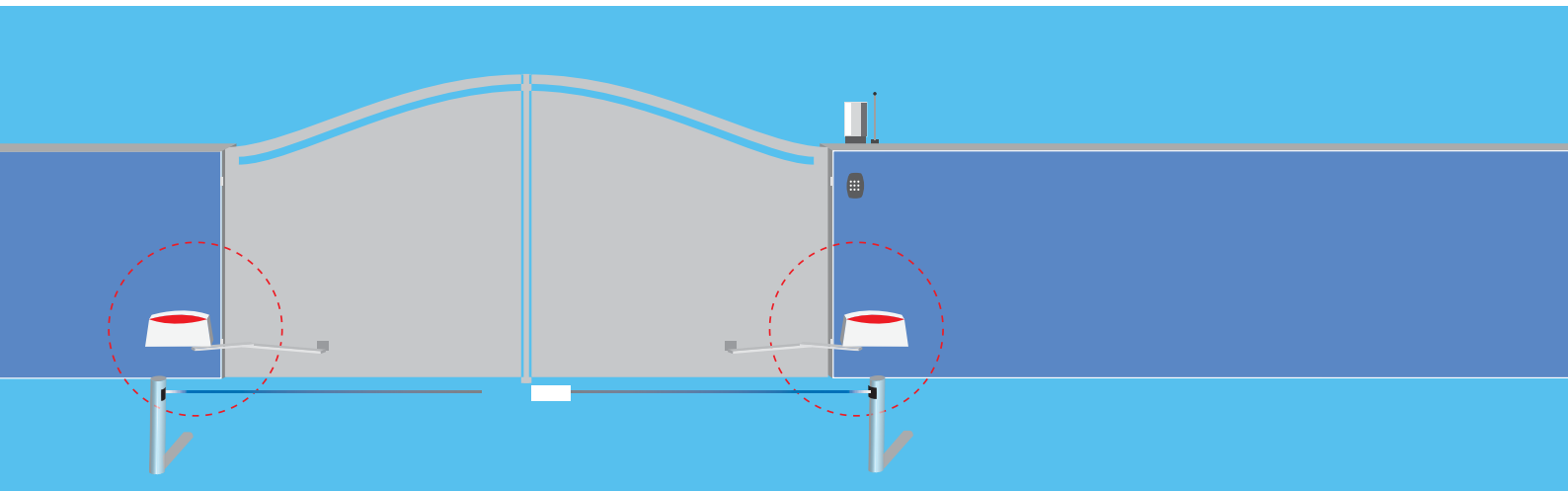

SINUO

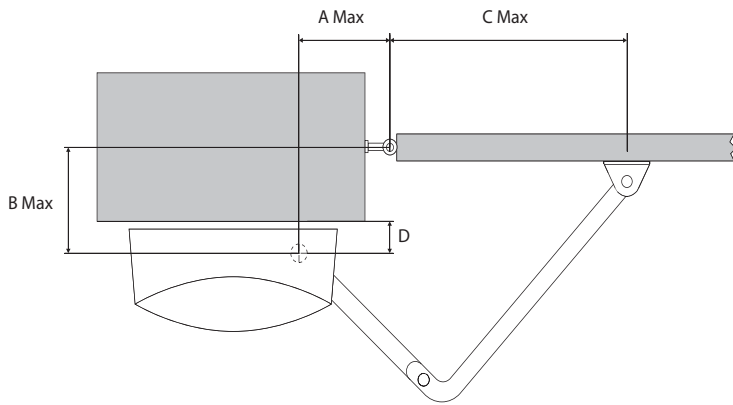

	STANDARD	ARMAX XL
A Max	160	420
B Max	370	470
C Max	480	820
D	87	87

Electromechanical irreversible gear motor with articulated arm for swing gates. External mounting.

Code	Door	Motor	Description	Pcs / Pallet	€ / Pcs
SIN 3 UNI DL	3 m	230V a.c.	Fast version equipped with electric open / close stopping. Capacitor supplied. Central unit not included.	20	449,00
SIN 5 UNI L DL	5 m	230V a.c.	Slow version equipped with electric open / close stopping. Capacitor supplied. Central unit not included.	20	489,00

UNI: motors without encoder

		SIN 3	SIN 5
Max weight wing (see graphic)	kg	400	600
Max lenght wing (see graphic)	m	3	5
Motor	V	230 V 50 Hz	230 V 50 Hz
Power	W	220	220
Thrust	Nm	280	350
Working temperature	°C Min/Max	-20 +70	-20 +70
Protection level	IP	44	44
Intermittence work cycle	%	35	35
Time for 90° cycle	s	12	18
Speed	rpm	1,7	1,1
Protection Level	°C	140	140

Limit use SINUO

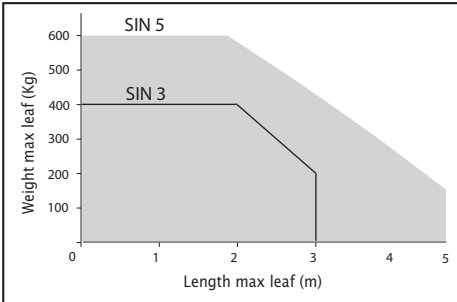

Reduce Limit use in case of windy area, or particular structural shape of the gate.

ARMAX XL € / Pcs 109,00



Oversized articulated arm.
(Pcs/Box 1)

ASECXL € / Pcs 49,00



External unblocking device
with metallic cable.
(Pcs/Box 1)

DOS € / Pcs 109,00



Key selector to release
mechanically the lock.
(Pcs/Box 1)

AELVE € / Pcs 159,00



Vertical Electrolock.
(Pcs/Box 1)

AELOR € / Pcs 159,00



Horizontal electrolock.
(Pcs/Box 1)

GE UNI RS DL € / Pcs 239,00



Control unit.
(Pcs/Box 1)

TL € / Pcs 2,90



Warning sign.

ERGO

Automtion for swing gates

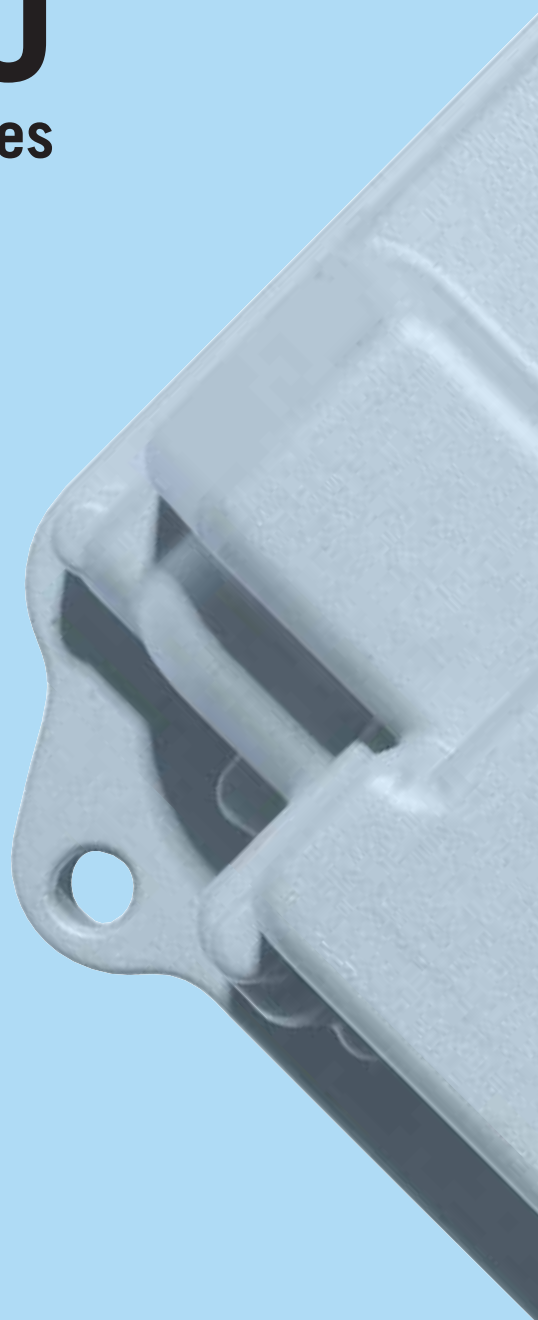
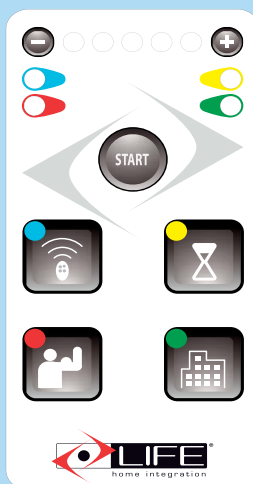



Automation for
swing gates





ERGO

Swing gate automation



Automation for swing gates

A new brand in home automation, a new name among underground motors for swing gates: **LIFE** introduces **Ergo**. This product range, as complete as it is innovative, offers an extensive choice of solutions: from the 230V version, with slow or fast movement, to the 24v version. Moreover, it guarantees all the quality of a state of the art design, all the duration and solid quality of the best materials, all the safety and functional quality of an evolved electronic system. Those who choose **LIFE** open the door to the future of automation.

Quality lies underneath

Ergo means more quality and attention given to detail, all combined in a system bound to last through time. The structure is a high density aluminium die-cast, which guarantees a superior lightness and inalterability. The gear motor's case is made of a die-cast and varnished with epoxy powders. The regularly shaped foundation box is made in galvanized steel with a copper ingredient to help it preserve through time. The thick bottom part has some drainage holes with plastic caps to avoid debris infiltration during installation. The actuator rests on two supports at a height of 20mm, to avoid piling up of dirt and allowing an easier maintenance.



A perfect machine

The release mechanism is perfectly protected from water and soil infiltrations. Plus, even though its use is foreseen as rare, the release mechanism has been designed to be carried out with maximum ease, simplicity and safety.

As per other **LIFE** models, **Ergo** is equipped with an integrated system composed by an optical "encoder", which detects any obstacle along the gate's way, even sudden ones, and an electronic control unit which activates any required safety measure in real time. Specific "limit switch" devices can also be added to the encoder, in order to have a quick response under any circumstance. Opening of the swing from 90° to 110° is controlled by a system with an easily adjustable hexagonal screw; the same convenience is also adapted during the closing phase.

Cleverly predisposed

LIFE simplifies the everyday work of the "workers involved": the **Ergo** model, in fact, is provided with clear assembly instructions that are complete and intuitive, following and assisting installation step by step. In addition, you have a quality capable to satisfy even the most demanding user, plus, a range of made to measure services. Enter the new world of home integration; it has never been so easy.

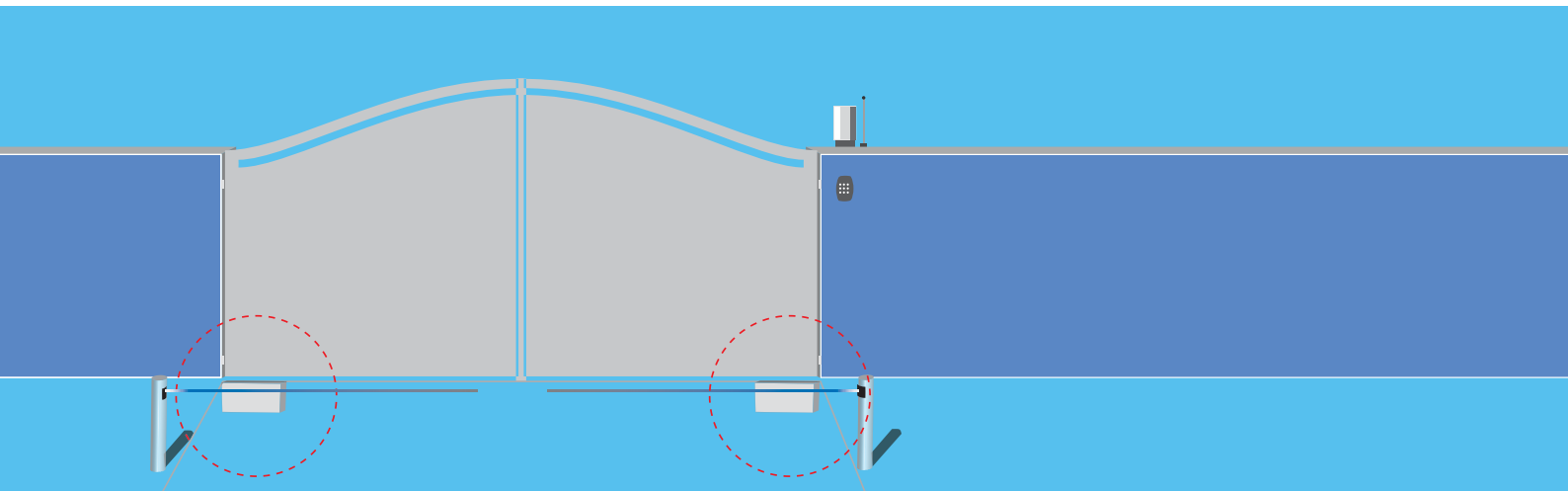

ERGO

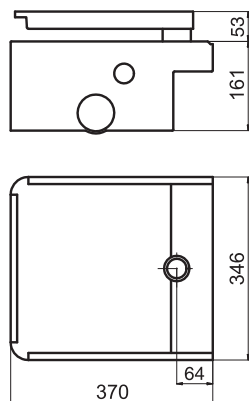

Electromechanical irreversible gear motor for swing gates. Underground installing.

Code	Wing	Motor	Description	Pcs / Pallet	€ / Pcs
ER4 24	3 m	24V d.c.	Irreversible gear motor, grease lubricated, with mechanical opening and closing stop. Version equipped with encoder and 2,5mt long. Pre-cabled wires.	16	429,00
ER4	3 m	230V a.c.	Fast irreversible gear motor, grease lubricated, with mechanical opening and closing stop .Version equipped with encoder and 2,5mt long. Pre-cabled wires. Capacitor supplied.	16	369,00
ER4L	3 m	230V a.c.	Slow irreversiile gear motor, grease lubricated, with mechanical opening and closing stop. Version equipped with encoder and 2,5mt long. Pre-cabled wires. Capacitor supplied.	16	369,00
ER4B	3 m	230V a.c.	Fast Irreversible gear motor, oil lubricated, with mechanical opening and closing stop .Version equipped with encoder and 2,5mt long. Pre-cabled wires. Capacitor supplied.	16	399,00
ER4 UNI DL	3 m	230V a.c.	Fast irreversible gear motor, grease lubricated, with mechanical opening and closing stop .Pre-cabled wires. Capacitor supplied.	16	359,00
ER4 UNI L DL	3 m	230V a.c.	Slow irreversiile gear motor, grease lubricated, with mechanical opening and closing stop .Pre-cabled wires. Capacitor supplied.	16	359,00

UNI: motors without encoder

		230V 50Hz			24V
		ER4 / ER4 UNI	ER4L	ER4B	ER424
Max weight wing (vedi grafici)	Kg	700	700	700	600
Max lenght wing (vedi grafici)	m	3	3	3	3
Motor supply	V	230V a.c.	230V a.c.	230V a.c.	24V d.c.
Power	W	300	300	300	120
Pair	Nm	350	350	350	250
Lubrification	Tipo	Grasso	Grasso	Olio	Grasso
Thermal cut-out	°C	140	140	140	-
Working temperature	°C Min/Max.	-20+70	-20+70	-20+70	-20+70
Protection level	IP	67	67	67	67
Time for 90° cycle	s	18	28	18	20
Intermittence work cycle	%	35	35	35	80

Limit use ERGO ER4

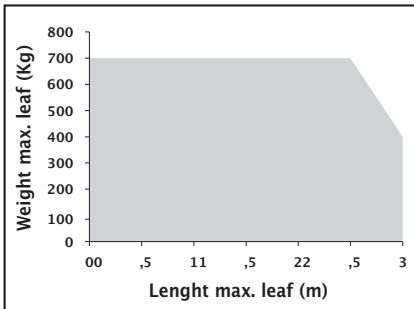

Limit use ERGO ER4 24

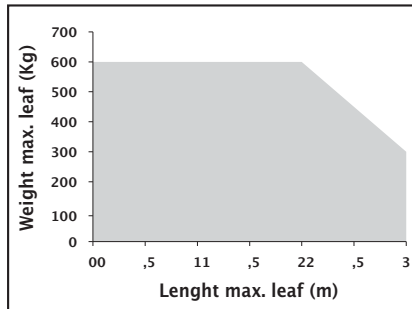

Reduce Limit use in case of windy area, or particular structural shape of the gate.

ERG € / Pcs 199,00



Foundation box complete with supports, caps levers & screws. Unblocking system not incl. Treatment with cataphoresis.

ERG CX € / Pcs 259,00



Foundation box complete with supports, caps levers & screws. Unblocking system not incl. Cataphoresis Box - Stainless steel cover

ERGX € / Pcs 369,00



Foundation box complete with supports, caps levers & screws. Unblocking system not incl. Stainless steel

AELVE € / Pcs 159,00



Vertical electrolock (Pcs/Box 1)

AELOR € / Pcs 159,00



Horizontal electrolock (Pcs/Box 1)

AER1 € / Pcs 129,00



Chain trasmission for opening up 180°. (for ERG, ERGX) (Pcs/Box 1)

TL € / Pcs 2,90



Warning sign

AMA2 € / Pcs 69,00



Unlock lever (Pcs/Box 1)

ACER

Automation for sliding gates

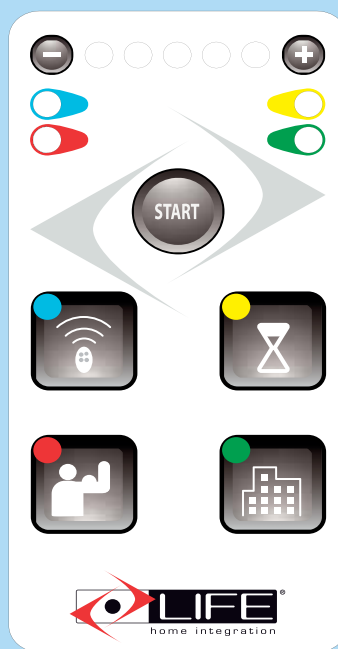



 LIFE

Automation for
sliding gates



ACER

Automation for sliding gates



Automation for sliding gates

From a new protagonist in the field of automation comes a new range of motors for sliding gates: **LIFE** introduces **Acer**. In the 230V and 24V versions up to 400, 600 and 1200 kg, this range of electromechanical actuators offers a wide possibility of choices together with an attentive design in every detail, in order to deliver the most advanced levels of quality, aesthetics and functionality available today. To choose **LIFE** means to move every day one more step in the direction of “home integration”: enter a world of safety, benefits and emotions.

Long lasting ideas and materials.

Acer is an innovative concept “coated” with materials and solutions to guarantee the best possible performance, also in terms of duration and safety. The structure is in high-density pressure-die cast aluminium, the best in lightweight and inalterability, even in severe weather conditions. The resistant external box protects from impact and bad weather both the electronic and mechanical components.

The latter has exemplary technical features: the whole motor body is finished with epoxy varnish, and the extremely solid machinery is produced with special alloys.



Simply the best.

All gate functions can be programmed as one pleases and with maximum simplicity, according to the needs of the user and to the various ways of employ.

The command panel, directly integrated into the protecting shield of the command central, is easily accessible as well as particularly intuitive in the functioning.

Moreover, two default programmes are already fitted, allowing instant use, even straight after installation.

Tranquillity comes first.

In addition to innovation, safety is one of the essential concepts of the **LIFE** philosophy, the reason why all models are fitted with an encoder.

Its function is to control the position and speed of the gate at all times and signal the presence of any obstacle to the electronic control unit. The latter instantly activates the measures required to avoid any incident. If this were not enough, there are also two “limit switch” devices that grant further safety.

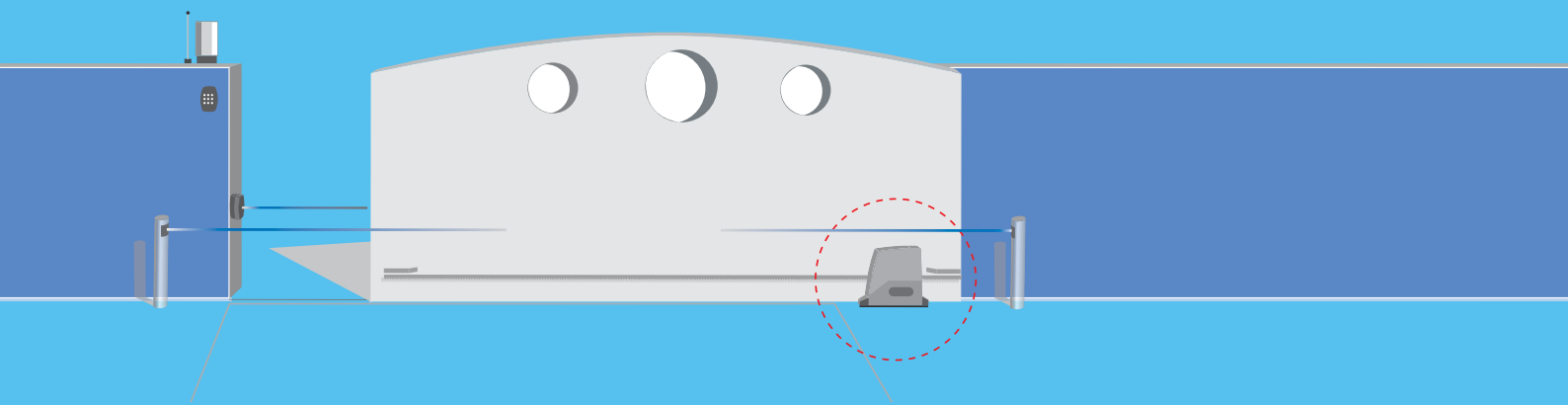

ACER

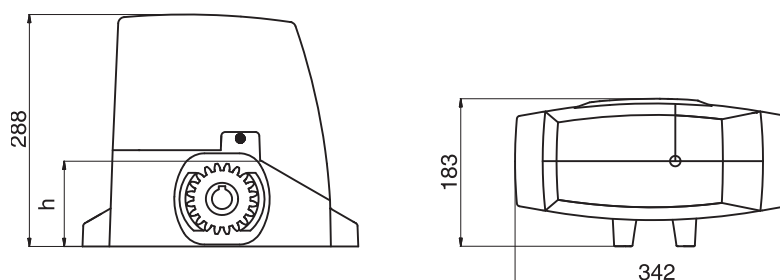

Electromechanical irreversible gear motor for sliding gates. External mounting.

Code	Door	Motor	Description	Pcs / Pallet	€ / Pcs
AC4R DL	400 Kg	230V a.c.	Version equipped with encoder, opening and closing electromechanical limit switches and central command unit (RG1R DL). Electrical clutch.	12/24	449,00
AC4R M DL	400 Kg	230V a.c.	Version equipped with encoder, opening and closing magnetic limit switches and central command unit (RG1R DL). Electrical clutch.	12/24	489,00
AC3R M 24 DL	300 Kg	24V d.c.	Version equipped with encoder, opening and closing magnetic limit switches and central command unit (RG1R 24 DL).	12/24	710,00
AC6R M 24 DL	600 Kg	24V d.c.	Version equipped with encoder, opening and closing magnetic limit switches and central command unit (RG1R 24 DL).	12/24	765,00
AC6R DL	600 Kg	230V a.c.	Version equipped with encoder, opening and closing magnetic limit switches and central command unit (RG1 R DL). Electrical clutch.	12/24	529,00
AC6R M DL	600 Kg	230V a.c.	Version equipped with encoder, opening and closing magnetic limit switches and central command unit (RG1R DL). Electrical clutch.	12/24	569,00
AC6M	600 Kg	230V a.c.	Version equipped with encoder, opening and closing magnetic limit switches and central command unit (RG1A). Electrical clutch.	12/24	499,00
AC8R DL	800 Kg	230V a.c.	Version equipped with encoder, opening and closing electromechanical limit switches and central command unit (RG1R DL). Cast iron gears	12/24	649,00
AC8R M DL	800 Kg	230V a.c.	Version equipped with encoder, opening and closing magnetic limit switches and central command unit (RG1R DL). Cast iron gears	12/24	680,00
AC12R DL	1200 Kg	230V a.c.	Version equipped with encoder, opening and closing electromechanical limit switches and central command unit (RG1R DL). Electrical clutch. Cast iron gears	12/24	731,00
AC12R M DL	1200 Kg	230V a.c.	Version equipped with encoder, opening and closing magnetic limit switches and central command unit (RG1R DL). Electrical clutch. Cast iron gears	12/24	771,00

		230V 50Hz				24V	
		AC4R DL	AC6R DL	AC8R DL	AC12R DL	AC3R M DL	AC6R M DL
Max weight wing	Kg	400	600	800	1200	300	600
Motor supply	V	230V a.c.	230V a.c.	230V a.c.	230V a.c.	24V d.c	24V d.c
Power	W	250	280	300	350	150	150
Thrust	N	500	700	900	1200	300	500
Lubrification	Tipo	Grease	Grease	Oil	Oil	Grease	Grease
Thermal cut-out	°C	140	140	140	140		
Working temperature	°C Min/Max	-20 +70	-20 +70	-20 + 70	-20 +70	-20 +70	-20 +70
Protection level	IP	44	44	44	44	44	44
Speed	m/min	10	10	8	8	6/12	11
Intermittence worj cycle	%	35	35	35	35	80	80
Height pinion (h)	mm	99	95	95	95	95	95

AAC1 € /mt 18,90



M4, 25x20x1000 rack, nylon slotten steel core, complete with screws. (Metre/Box 10)

AAC3 € / mt 23,90



M4, 30x12x1000 rack, galvanized and slotted complete with screws and spacers (Metre/Box 10)

AGECH € / Pcs 49,00



Battery charger additional circuit for control boards (see table at page 94) (Pcs/Box 1)

AGE12 € / Pcs 120,00



Battery 12V - 2,3 Ah. (Pcs/Box 2)

TL € / Pcs 2,90



Warning sign



230V complete 50Hz Setup for single-wing sliding gates automation.



SETUP ACER DL



FID02
1 Transmitter
433,92 MHz
LIFE Rolling Code
Page 104



DES
1 Key selector
for external
use
Page 117



VISIO
1 External pair
of photocells
Page 121



SPL
1 Flashlight
Page 127



SKANX
1 Matching
antenna and
coaxial cable
Page 127



RG 1R DL
1 Control unit
with receiver
integrated
Page 93



TL
1 Warning sign.

Code	Door	Gear Motors	Limit switches	Setup / Pallet	€ / Setup
SETUP AC4R DL	400 Kg	AC4R DL	Electromechanic	24	575,00
SETUP AC6R DL	600 Kg	AC6R DL	Electromechanic	24	649,00
SETUP AC8R DL	800 Kg	AC8R DL	Electromechanic	24	763,00
SETUP AC12R DL	1200 Kg	AC12R DL	Electromechanic	24	839,00
SETUP AC4RM DL	400 Kg	AC4RM DL	Magnetic	24	612,00
SETUP AC6RM DL	600 Kg	AC6RM DL	Magnetic	24	689,00
SETUP AC8RM DL	800 Kg	AC8RM DL	Magnetic	24	800,00
SETUP AC12RM DL	1200 Kg	AC12RM DL	Magnetic	24	877,00



230V complete Setup for single-wing sliding gates automation.



SETUP ACER DL



FID02

1 Transmitter
433,92 MHz
LIFE Rolling Code
Page 104



VISIO

1 External pair
of photocells
Page 121



SKANT

1 Matching
antenna and
coaxial cable
Page 127



RG 1R DL

1 Control unit
with receiver
integrated
Page 93

Code	Door	Gear Motors	Limit switches	Setup / Pallet	€ / Setup
SETUP AC4R DL S	400 Kg	AC4R DL	Electromechanic	24	516,00
SETUP AC6R DL S	600 Kg	AC6R DL	Electromechanic	24	592,00
SETUP AC8R DL S	800 Kg	AC8R DL	Electromechanic	24	704,00
SETUP AC12R DL S	1200 Kg	AC12R DL	Electromechanic	24	781,00
SETUP AC4RM DL S	400 Kg	AC4RM DL	Magnetic	24	554,00
SETUP AC6RM DL S	600 Kg	AC6RM DL	Magnetic	24	629,00
SETUP AC8RM DL S	800 Kg	AC8RM DL	Magnetic	24	742,00
SETUP AC12RM DL S	1200 Kg	AC12RM DL	Magnetic	24	819,00



230V complete 50Hz Setup for single-wing sliding gates automation.



SETUP ACER DL



FID02

2 Transmitters
433,92 MHz
LIFE Rolling Code
Page 104



RG 1R DL

1 Control unit
with receiver
integrated
Page 93

Code	Door	Gear Motors	Limit switchers	Setup / Pallet	€ / Setup
SETUP AC4R DL EASY	400 Kg	AC4R DL	Electromechanic	24	473,00
SETUP AC6R DL EASY	600 Kg	AC6R DL	Electromechanic	24	548,00
SETUP AC8R DL EASY	800 Kg	AC8R DL	Electromechanic	24	661,00
SETUP AC12R DL EASY	1200 Kg	AC12R DL	Electromechanic	24	738,00
SETUP AC4RM DL EASY	400 Kg	AC4RM DL	Magnetic	24	511,00
SETUP AC6RM DL EASY	600 Kg	AC6RM DL	Magnetic	24	585,00
SETUP AC8RM DL EASY	800 Kg	AC8RM DL	Magnetic	24	699,00
SETUP AC12RM DL EASY	1200 Kg	AC12RM DL	Magnetic	24	776,00



24V complete Setup for single-wing sliding gates automation.



SETUP ACER DL



FID02

1 Transmitter
433,92 MHz
LIFE Rolling Code
Page 104



DES

1 Key selector
for external
use
Page 117



VISIO

1 External pair
of photocells
Page 121



SPL24

1 Flashlight
Page 127



SKANX

1 Matching
antenna and
coaxial cable
Page 127



RG 1R 24 DL

1 Control unit
with receiver
integrated
Page 93



TL

1 Warning sign.

Code	Door	Gear Motors	Limit switches	Setup / Pallet	€ / Setup
SETUP AC3R M 24 DL	300 Kg	AC3 RM 24 DL	Magnetic	24	820,00



FID02

1 Transmitter
433,92 MHz
LIFE Rolling Code
Page 104



VISIO

1 External pair
of photocells
Page 121



SKANT

1 Matching
antenna and
coaxial cable
Page 127



RG 1R 24 DL

1 Control unit
with receiver
integrated
Page 93

Code	Door	Gear Motors	Limit switches	Setup / Pallet	€ / Setup
SETUP AC3R M 24 DL S	300 Kg	AC3 RM 24 DL	Magnetic	24	761,00



FID02

2 Transmitters
433,92 MHz
LIFE Rolling Code
Page 104



RG 1R 24 DL

1 Control unit with
receiver and radio
integrated
Page 93

Code	Door	Gear Motors	Limit switches	Setup / Pallet	€ / Setup
SETUP AC3R M 24 DL EASY	300 Kg	AC3 RM 24 DL	Magnetic	24	718,00



MADE IN ITALY

SUPRA

Road Barriers

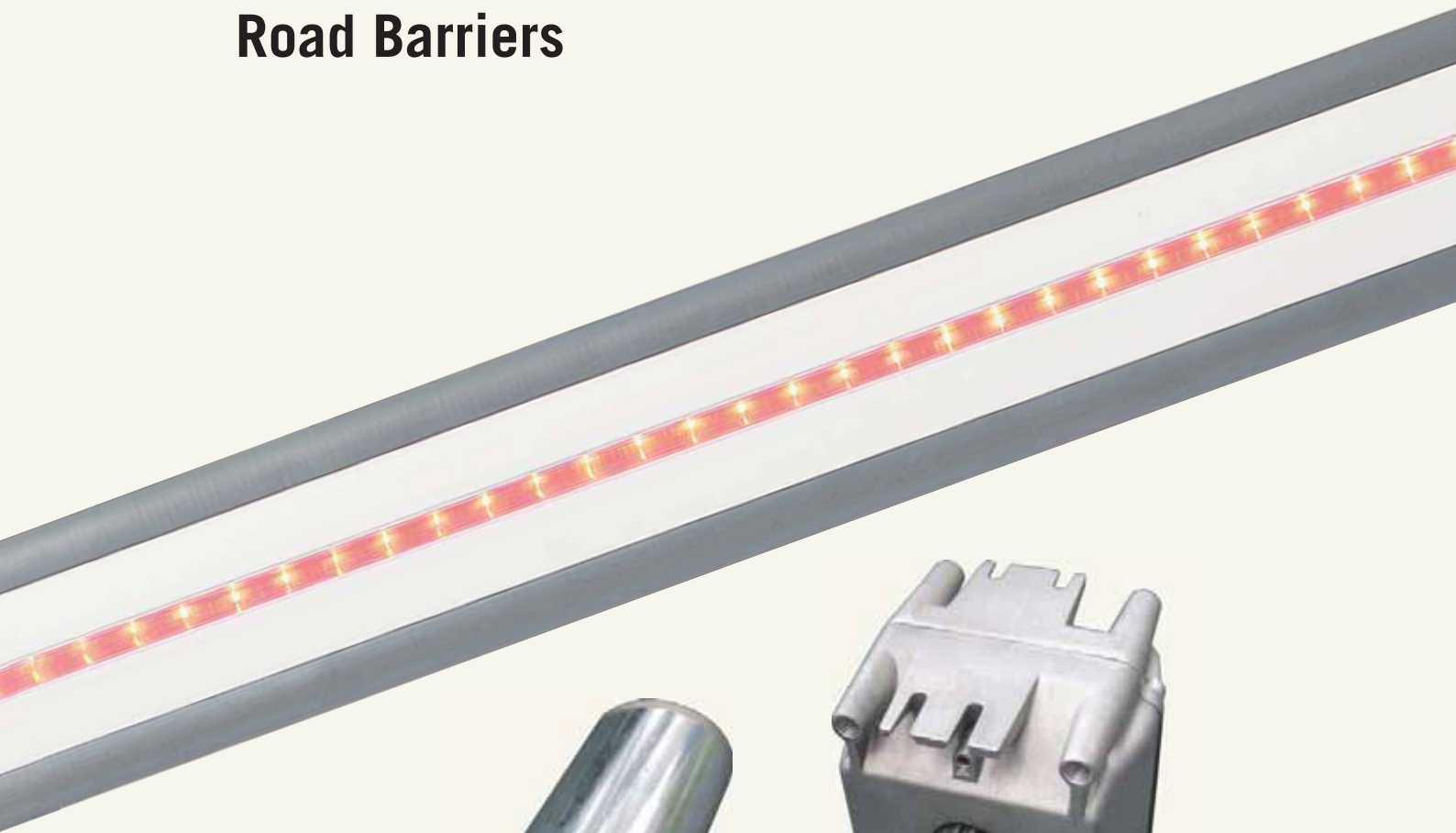



Road
Barriers

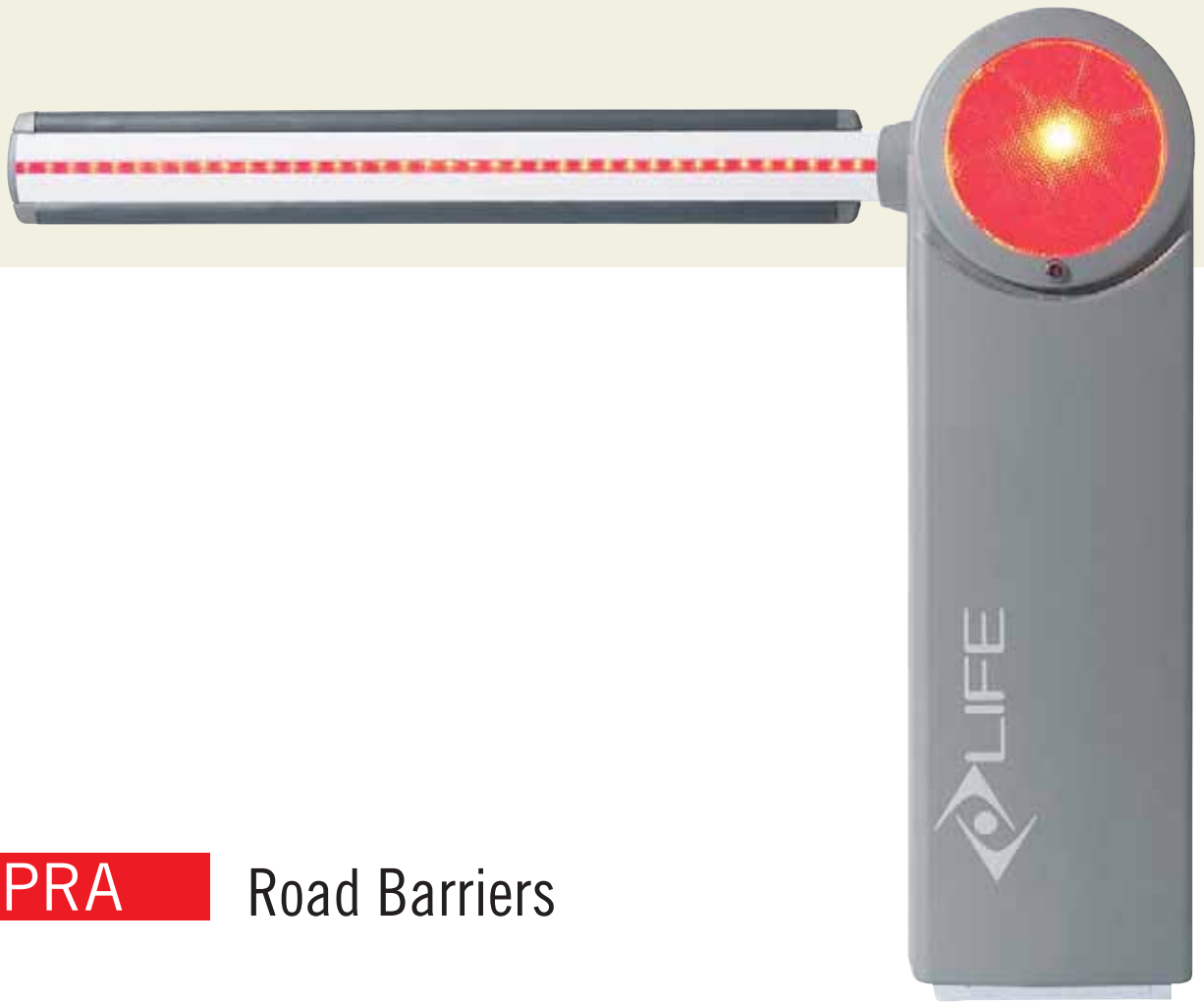

SUPRA

Road Barriers



Automation for road barriers

From a new leader in the field of automation, a new range of road barriers: **LIFE** introduces **Supra**. In the 24Vdc motor version, with boom up to 5 mt, this family of electromechanical actuators offers a wide possibility of choices and an engineering careful at every detail, in order to express the most advanced levels of quality, functionality and aesthetics available today. Choosing **LIFE** means taking each day a further step into the "home integration": come into a world of safety, benefits and emotions.

A touch of class

Supra stands for better quality and even more care put into detail, for a system bound to last in time. This is why its shell, a galvanized steel porting structure, has been coated with a solid plastic shockproof armour, inspired by the automobile world. **LIFE** makes the difference and introduces **Supra**: a "diva" on the scene of road barrier automation. Power and control dressed up with the same elegance and class of the most prestigious automobiles on the market.



Easy does it

All the barrier's functions can be programmed as one pleases with ease, according to specific needs and requirements. The control panel, perfectly integrated and protected by the superior shell is easily accessible, and extremely intuitive. Furthermore, there are two default programs already set, which allow to use the system immediately after installation.

Simple installation, immediate integration

The protocol and interface make it easier installing photocells, transponders, digital selectors and other command devices. New components are immediately acknowledged, thanks to the "plug and play" system: therefore the system can be updated and expanded at any time. Just three steps are necessary to configure installation: a smart instrument that's always capable of supplying an answer for any requirement and a solution for your installing and user needs. Clear, simple and intuitive assembly instructions help reduce installation time. With **LIFE's** quality, design and customized services, you will reach the highest levels of technical satisfaction.

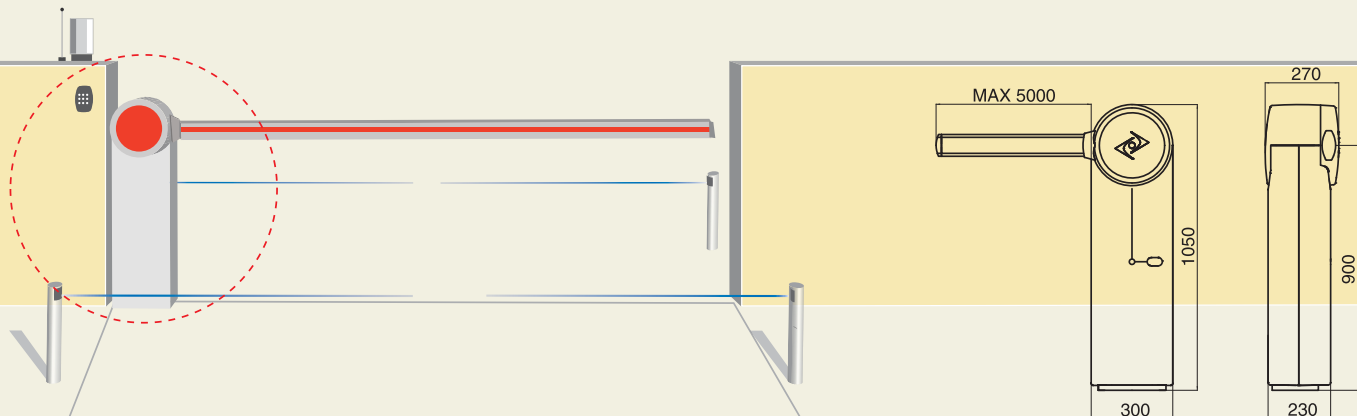

SUPRA

Automatic road barrier with boom up to 5 meters.

Code	Motor	Description	€ / Pcs
SU4 24	24V d.c.	Irreversible electromechanical gear motor mounted on a galvanized steel box with plastic shockproof cover.	1.199,00
3 nda 5 mt max		Model equipped with encoder, electromechanical limit switches in opening and closing and central command unit. (RG1A 24).	

SUB3	€ / Pcs 149,00	SUB4	€ / Pcs 179,00	SUB5	€ / Pcs 199,00	SUE1	€ / Conf. 59,00
-------------	----------------	-------------	----------------	-------------	----------------	-------------	-----------------



Modular channelled boom
L= 3,3 meters (Pcs/Box 1)



Modular channelled boom
L= 4,3 meters. (Pcs/Box 1)



Modular channelled boom
L= 5,3 meters. (Pcs/Box 1)



Soleplate with clamps
(Pcs/Box 1)

SUC1	€ /conf. 60,00	SUM1	€ / Pcs 109,00	SUM2	€ / Pcs 119,00	SUM3	€ / Pcs 139,00
-------------	----------------	-------------	----------------	-------------	----------------	-------------	----------------



Protective rubber, L= 10 meters
with accessories. (Pcs/Box 1)



Balancing spring
(Pcs/Box 1)



Balancing spring
(Pcs/Box 1)



Balancing spring
(Pcs/Box 1)

S U4 24

CRITERIA FOR CHOOSING THE BALANCING SPRING

		S U4 24			CRITERIA FOR CHOOSING THE BALANCING SPRING		
Max length boom	M	5			3 mt	4 mt	5 mt
Power supply	V	230V 50Hz		Simple boom + protective rubber	SUM1	SUM1	SUM2
Motor supply	V	24V		Channelled boom + protective rubber	SUM1	SUM2	SUM3
Power	W	150		Channelled boom + luminous cordon + protective rubber	SUM2	SUM3	SUM3
Pair	Nm	150		Channelled boom + protective rubber + movable stand	SUM2	SUM3	SUM3
Working temperature	°C Min/Max	-20 +70		Channelled boom + protective rubber + luminous cordon + movable stand	SUM2	SUM3	SUM3
Protection level	IP	44					
Intermittence work cycle	%	80					
Opening time	s	2 ÷ 6					

Nota: The above combinations are merely indicative and represent just a few among the most common installations. For support in cases not contemplated above please contact LIFE technical assistance and guidance.

Road Barriers

SUC3 € / Kit 69,00



Kit connecting cable for illuminated cordon.

SUC2 € / mt 18,00



Illuminated cordon for channelled boom.

SUC5 € / Box. 30,00



Profile for protective with illuminated cordon.
L=2 meters. (Metre/Box 10)

SUSPL € / Pcs 179,00



Light barrier.
(Pcs/Box 1)

SUC4 € / Box. 39,00

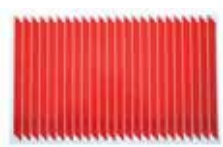

Refracting band.
(Pcs/Box 18)

SUD1 € / Pcs 89,00



Fixed stand for SUA and SUB. (Pcs/Box 1)

SUD2 € / Pcs 69,00



Movable stand for boom SUB.
(Pcs/Box 1)

SUS1 € / Pcs 19,00



Supporting racket for two AGE12 batteries.
(Pcs/Box 1)

AGECH XL € / Pcs 49,00



Battery charger additional circuit for control boards
(see table at page 94)
(Pcs/Box 1)

AGE12 € / Pcs 120,00



Battery 12V - 2,3 Ah.
(Pcs/Box 2)

PROBO

Automtionr sectional and up
and over doors

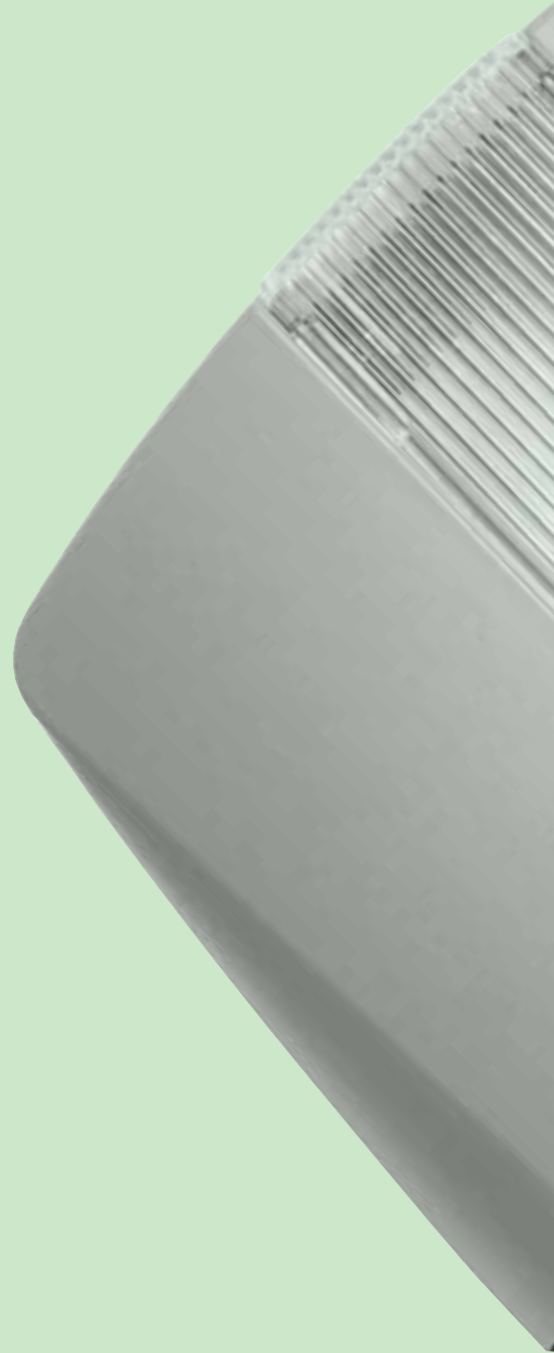



PALIFE

Automation for sectional
and up and over doors



PROBO

Automation for sectional and up and over doors

Automation for sectional to up and over doors

LIFE innovates the residential automation scene with a range of avant-garde solutions, such as **Probo**, a specific family of towing motors for sectional and up and over doors.

Aside from the possibility of choosing from various power strengths, **Probo** offers the performance of a motor specifically developed for these kind of applications, the versatility of programmable functions, the high quality of engineering and manufacturing carried out in every detail, an avant-garde design.

Try the benefits of **LIFE**: for sure, a step forward towards “home integration”.

Special materials, original concepts

Probo model has been developed out of **LIFE**'s research for new technologies and systems to solve everyone's requirements: even the most specific. More, the best raw materials are employed and the article is manufactured following the most strict quality standards, to guarantee a long duration and perfect functioning throughout time.

The motor has been expressly studied and optimized for towing of sectional and up and over doors. The unblocking is simple and intuitive, and the hooking to initial position is automatic. Both kinds of transmission, chain or belt, assure great reliability and an excellent acoustic comfort.



Safety in real time

A sudden obstacle crosses the door's range of travel? No problem: **Probo** models have a special encoder that, in the case on unforeseen events, immediately alerts the electronic central unit. The latter activates the required countermeasures, in order to guarantee total safety for objects and people.

The command panel, easily accessible, is simple to use and allows programming and adjusting of all the motor's functions.

Moreover the electronic central unit is already programmed with two default programs that help speeding up the installation: just a simple touch and the system is ready for use.

Simple installation, evolved services

LIFE knows the practical needs of installers, that's why it has studied every detail in order to make their work simpler, easier and gratifying.

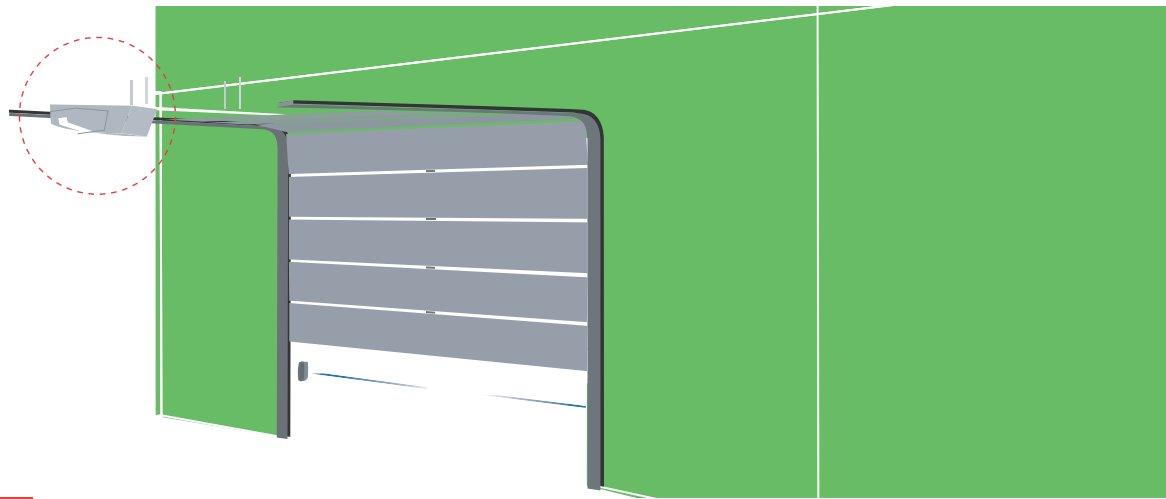

Assembling instructions are clear, complete, readable and take the operator step by step. A saving of time and effort are the end result, and a perfect outcome is achieved: another benefit of **LIFE** products. Beyond a complete set of solutions, there is a range of customized commercial and technical services: the future of “home integration” has already begun.

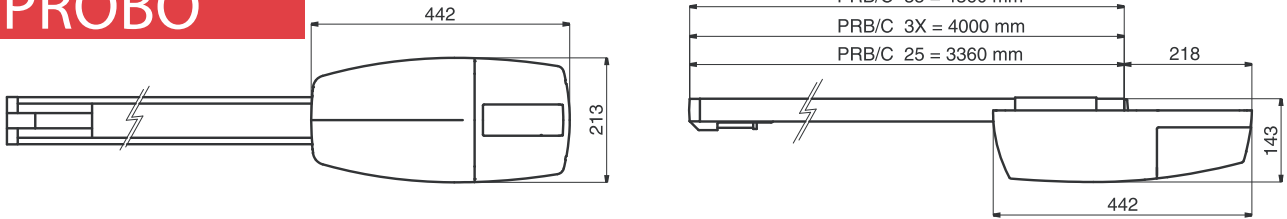

PROBO



Electromechanical irreversible towing gear motor for sectional and up-and-over doors.

Code	Door	Motor	Description	Pcs / Pallet	€ / Pcs
PR70-DL 	10 mq	24V a.c.	Irreversible gear motor with 700N maximum strength, equipped with encoder. Command central unit RG1 24DL with integrated LIFE 433,92 MHz radio receiver. Double-channel transmitter included.	50	299,00
PR120-DL 	16 mq	24V a.c.	Irreversible gear motor with 1200N maximum strength, equipped with encoder. Command central unit RG1 24DL with integrated LIFE 433,92 MHz radio receiver. Double-channel transmitter included.	50	399,00

Sliding guide complete with fixing brackets and straight arm. BELT transmission.



Code	Transmission	Segments	Height max gate	€ / Pcs
PRB25-08	Belt	2	2,5 m	115,00
PRB3X-08	Belt	1	3.0 m	125,00

Sliding guide complete with fixing brackets and straight arm. CHAIN transmission.



Code	Transmission	Segments	Height max gate	€ / Pcs
PRC25-08	Chain	2	2,5 m	115,00
PRC35-08	Chain	3	3,5 m	139,00
PRC3X-08	Chain	1	3,0 m	125,00

APRB € / Pcs 89,00



Oscillating bended arm with roller sliding for up-and-over projecting doors.
(Pcs/Box 1)

APRSK € / Kit 15,00



Additional fixing bracket.
(Kit/Box 1)

PRC12 € / Kit 49,00



1250 mm extension for PRC sliding guide. Kit complete with junction, chain part and joining link.
(Kit/Box 1)

		PR70DL	PR120DL
		230V 50Hz	230V 50Hz
Power supply	m Ω		
Door max surface	V	10	16
Motor supply	W	24	24
Power	W	50	90
Thrust	N	700	1200
Working temperature	$^{\circ}$ C Min/Max	-20 +70	-20 +70
Protection level	IP	40	40
Intermittence work cycle	%	50	50

ASEC € / Kit 69,00



Complete unblocking handle kit.
(Kit/Box 1)

AGECH € / Pcs 49,00



Battery charger additional circuit
for control boards
(see table at page 94)
(Pcs/Box 1)

AGE12 € / Pcs 120,00



Battery 12V - 2,3 Ah.
(Pcs/Box 2)

PLUS

Automation for up and over doors





LIFE

Automation for up
and over doors



PLUS

Automation for up and over doors



Automation for up and over doors

LIFE presents itself as a new reference point in “home integration” and introduces Plus, the motor for up and over doors that will better the quality of your life. Plus satisfies any requirement: offered in a 230V SUPPLY, it is predisposed to accommodate a 24V motor and to reach maximum safety levels. Plus couples the highest duration of performances and solidity with a design pleasantly modern and an avant-garde electronic system. In fewer words, **Plus** gives you more: that’s **LIFE**’s philosophy.

A novelty designed to last

The **Plus** model has been developed and manufactured without losing quality. The structure is high density aluminium die-cast, a material which is as light as inalterable. The external shell, a **LIFE** trademark, is undeformable.

The motor shaft and the basic mechanism lay on oversized ball bearings, bronze bearings with gauge, in order to grant maximum solidity and duration. In the version with central command unit included, the command panel integrated in the protection shell allows to customize all functions. More, two default programs are already installed, with a preconfigured adjustment capable to satisfy the most common requirements: it can’t get easier than that.



An electronic eye for your safety

Just like every other **LIFE** model, **Plus** is also supplied with an “encoder”: this device can monitor in real time the position of the door already installed or fitted externally, the presence of any possible obstacle. Practically, it’s like you had a guardian looking after your safety. But that not all: the system also comes with limit switches ready to operate automatically, both in opening and closing.

Quicker installation, easier maintenance

LIFE has considered everything in order to better the life of its end users, but also to make the work of technicians and installers simpler.

The limit switch devices are already cabled, and the protection shell can be easily extracted due to two screws positioned on the front. One of these also holds the courtesy light window, which can be easily opened to change the light bulb. With **LIFE** quality, design and customized services it is easy to enter a world of benefits.

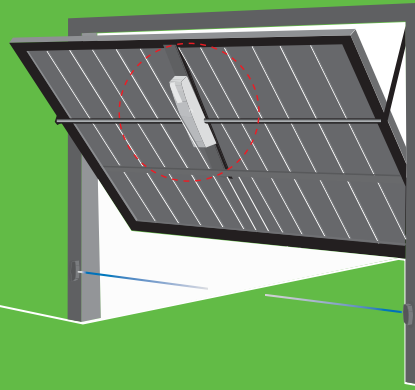

PLUS

For overhead doors overflowing and no-overflowing until 9 sq.mt. (until 14 sq.mt. with 2 motors and hinged doors)

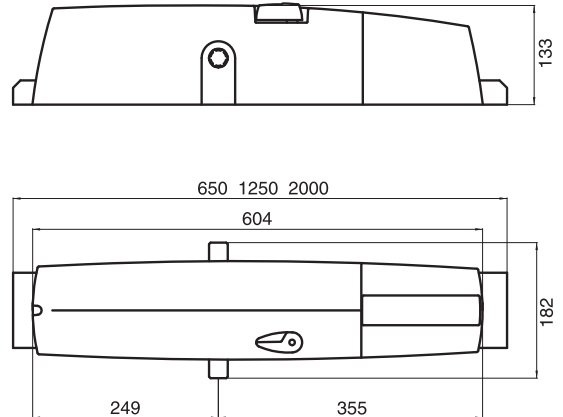

Irreversible electromechanical gear motor for projecting and non-projecting up-and-over doors.

Code	Door	Motor	Description	Pcs / Pallet	€ / Pcs
PL1	9 mq	230V a.c.	Irreversible fast gear motor. Equipped with encoder. Opening and closing limit switches. Central command unit RG1A integrated on board.	20	459,00
PL1L	9 mq	230V a.c.	Irreversible slow gear motor. Equipped with encoder. Opening and closing limit switches. Central command unit RG1A integrated on board.	20	459,00
PL2	9 mq	230V a.c.	Irreversible fast gear motor. Equipped with encoder. Opening and closing limit switches. Central command unit RG1A integrated on board.	20	309,00
PL2L	9 mq	230V a.c.	Irreversible slow gear motor. Equipped with encoder. Opening and closing limit switches. Central command unit RG1A integrated on board.	20	309,00

GE1A € / Pcs 169,00

PLA15 € / Kit 69,00

PLA20 € / Kit 78,00

PLA03 € / Kit 56,00



Control unit.
(Pcs/Box 1)



Transmission shaft, 1500 mm long with welded fluted bush, equipped with bracket and fixing screws. (Pcs/Box 2)



Transmission shaft, 2000 mm long with welded fluted bush, equipped with bracket and fixing screws. (Pcs/Box 2)



Galvanized transmission shaft, 100mm long with welded fluted bush, equipped with bracket and fixing screws. (Pcs/Box 2)

		PL1	PL2	PL1L	PL2L
Door max surface	m ²	9	9	9	9
Motor supply	V	230V 50Hz	230V 50Hz	230V 50Hz	230V 50Hz
Power	W	210	210	220	220
Pair	Nm	350	350	350	350
Thermal cut-out	°C	140	140	140	140
Working temperature	°C Min/Max	-20 +70	-20 +70	-20 +70	-20 +70
Protection level	IP	40	40	40	40
Speed	rpm	1,7	1,7	1,1	1,1
Intermittence work cycle	%	30	30	30	30

PLA	€ / Kit 26,00	PLA01	€ / Pcs 16,00	PLB1	€ / Kit 22,00	PLB2	€ / Kit 33,00
------------	---------------	--------------	---------------	-------------	---------------	-------------	---------------



Fixing brackets kit with adjustable slide for transmission shafts PLA15 and PLA20. (kit/Box 2)



Galvanized coupling bush to be welded on telescopic arm PLB1, PLB2 e PLB4.



Standard straight telescopic arm. Sheath, length 700mm. Shaft, length 700 mm. Double adjustable "L" shaped bracket.



Long straight telescopic arm. Sheath, length 1500mm. Shaft length 700. Double adjustable "L" shaped bracket.

PLB3	€ / Kit 32,00	PLB3F	€ / Kit 79,00	PLB4	€ / Kit 33,00	PLB4F	€ / Kit 99,00
-------------	---------------	--------------	---------------	-------------	---------------	--------------	---------------



Standard straight telescopic arm with fluted welded bush. Double adjustable "L" shaped bracket.



Standard straight telescopic arm with smooth welded bush for direct fixing on transmission shaft. Double adjustable "L" shaped bracket.



Standard curved telescopic arm bush. Double adjustable "L" shaped bracket.



Left and right standard curved telescopic arm with welded bushing for direct fixing on transmission shaft. Double adjustable "L" shaped bracket.

PLS5	€ / Pcs 19,00	PLS10	€ / Pcs 36,00	PLS20	€ / Pcs 49,00
-------------	---------------	--------------	---------------	--------------	---------------



Gear motor support racket 530mm long.



Gear motor support racket 1250mm long.



Gear motor support racket 2000mm long.

PLSBA	€ / Kit 19,00	PLSBC	€ / Kit 19,00	ASECPL	€ / Kit 30,00	TL	€ / Pcs 2,90
--------------	---------------	--------------	---------------	---------------	---------------	-----------	--------------



External unlocking device With rigid rod.



External unlocking device with removable key ratchet.



External unlocking device +with metal wire bush. Double adjustable "L" shaped bracket.



Warning sign.



230 V complete 50Hz Setup for automation of projecting and non-projecting up-and-over doors.

SETUP PLUS



FID02
1 Transmitter
433,92 Mhz
LIFE Rolling Code
Page 104



DES
1 key selector
for external use
Page 117



SPL
1 Flashlight
Page 127



SKANX
1 Matching
antenna and
coaxial cable.
Page 127



RG1 A
1 Control
unit
Page 93



FAST R2
1 Receiver
433,92 MHz
Page 99



PLB3F
1 Couple of
Telescopic
arms.
Page 68



TL
1 WARNING Sign.

Code	Door	Gear Motor	Setup / Pallet	€ / Setup
SETUP PLUS	9 mq	PL1L	20	648,00



ACCESS. SETUP PLUS

PLA15 € / Kit 69,00



Transmission shaft, 1500 mm Long, with welded fluted bush, equipped with bracket and fixing screws.
(Pcs/Box 2)

PLA20 € /Kit 78,00



Transmission shaft, 2000 mm Long, with welded fluted bush, equipped with bracket and fixing screws.
(Pcs/Box 2)

PLS5 € / Pcs 19,00



Gear motor support bracket 530mm long.

PLS10 € / Pcs 36,00



Gear motor support bracket 1250 mm long.

PLS20 € / Pcs 49,00



Gear motor support bracket 2000 mm long.

PLSBA € / Kit. 19,00



External unlocking device With rigid rod.

PLSBC € / Kit. 19,00



External unlocking device with removable key ratchet.

ASECPL € / Kit. 30,00



External unlocking device +with metal wire bush. Double adjustable "L" shaped bracket.



MADE IN ITALY

VIS

Automation for industrial doors





**PRECISION
AND
QUALITY**



VIS

Automation for industrial doors



Automation for industrial doors

LIFE renew the landscape of automation for industrial doors with a range of innovative solutions like VIS, a specific family of engines for overhead and sliding doors. In addition to the possibility of choosing between different modes of installation, **Vis** offers the performance of an engine designed for this type of application, the versatility of the programmable functions, the quality of a design and implementation of an attention to every detail, the the charm of a cutting edge design. Experience for yourself the benefits **LIFE**: definitely a step beyond "Home Integration".

Special materials, original concepts

The **Vis** model has been developed through **LIFE**'s research for new technologies and systems to solve anyone's requirements: even the most specific ones, coming from the industrial field. To manufacture this model, the highest materials and quality standards are involved, in order to assure a long-lasting life and a perfect functioning through time. The gear motor has been specifically designed for sectional and sliding industrial doors. The release system is simple and intuitive, and the hooking to initial position is automatic. Both kinds of transmission, chain or direct drive, guarantee a higher reliability and fine acoustic comfort.



An electronic eye for your safety

As with all **LIFE** motors, the **Vis** model is available with encoder: this equipment monitors in real time the position of the door and indicates this to the electronic central unit, installed externally or onboard, the eventual presence of obstacles along the run. In the end, it's just like having at your disposal an unfailing guardian looking after your safety. But it's not enough: the system also includes the limit switches with micrometer adjustment, ready to activate automatically, in opening and in closing

A novelty designed to last

The **Vis** models have been designed and manufactured without losing any quality. The structure is made in aluminium high density die-cast, a material which is as light as resistant. The external shell, a **LIFE** "brand signature", is not deformable. The drive shaft and the machinery operate on larger ball bearings of superior quality, to assure longlasting life. In the version with control unit onboard, the command keyboard is integrated into the protective shell and allows customization of all functions, so to satisfy even the most specific requirements: it can't get easier.

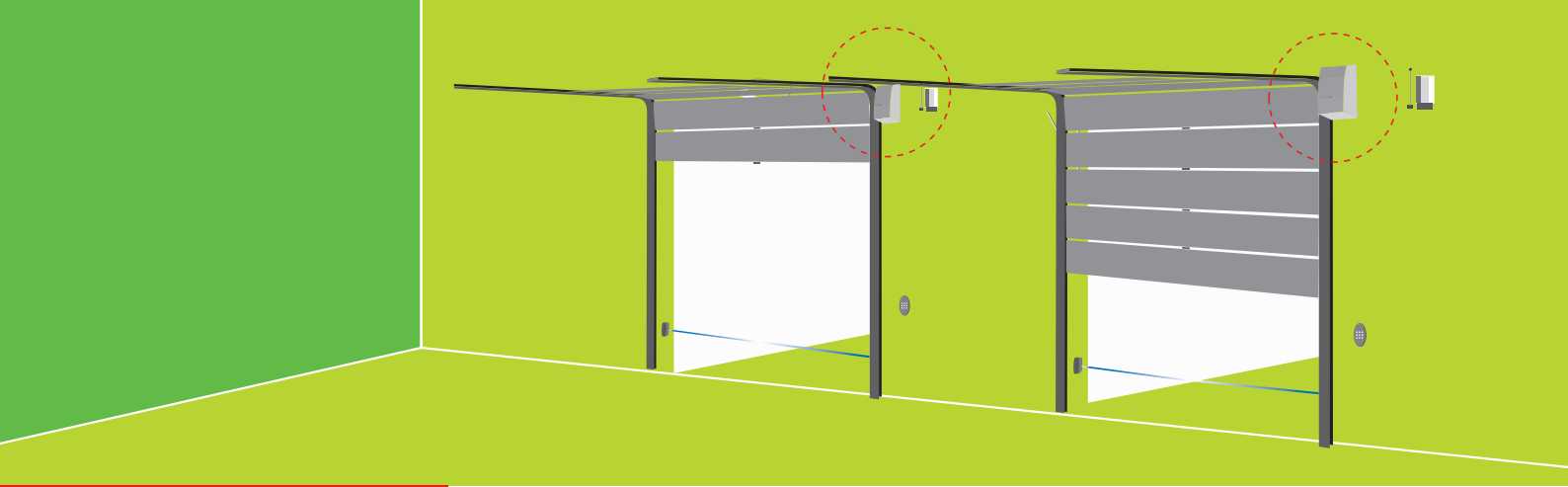

VIS

For sectional doors over 22 sq.mt. and until 34 sq. mt. it needs the use of kit VISCH

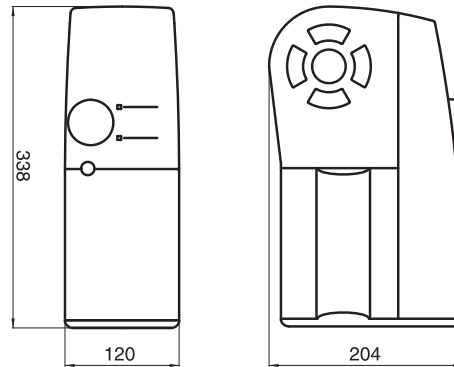

Irreversible electromechanical gear motor for sectional door and sliding book doors.

Code	Door	Motor	Description	Pcs / Pallet	€ / Pcs
VIS	22/34* mq	230V a.c.	Irreversible electromechanical gear motor equipped with encoder and open/close limit switch. Central command unit not integrated on board.	18	539,00

* with VISCH accessories

		VIS	
Door max surface	m ²	22/34*	
Motor supply	V	230V 50Hz	
Power	W	450	
Pair	Nm	45/70*	
Weight	Kg	15	
Thermal cut-out	°C	140	
Working temperature	°C Min/Max	-20 +50	
Protection level	IP	54	
Speed	rpm	20	
Intermittence work cycle	%	35	

VISFX1 € / Pcs 29,00



Standard fixing bracket
(Pcs/Box 1)

VISMV € / Pcs 99,00



Manual winch (10 mt chain)
(Pcs/Box 1)

VISBLK € / Box 9,00



Unblocking system H=3 metri.
(Kit/Box 1)

VISCH* € / Pcs 172,00



Kit chain
(Kit/Box 1)

GEVISR DL € / Pcs 230,00



Control unit.
(Pcs/Box 1)

GEVISR DL AC € / Pcs 299,00



Control unit with pushbuttons.
(Pcs/Box 1)

TL € / Pcs 2,90



Warning sign.



MADE IN ITALY

SINUO DOOR

Automation for book doors



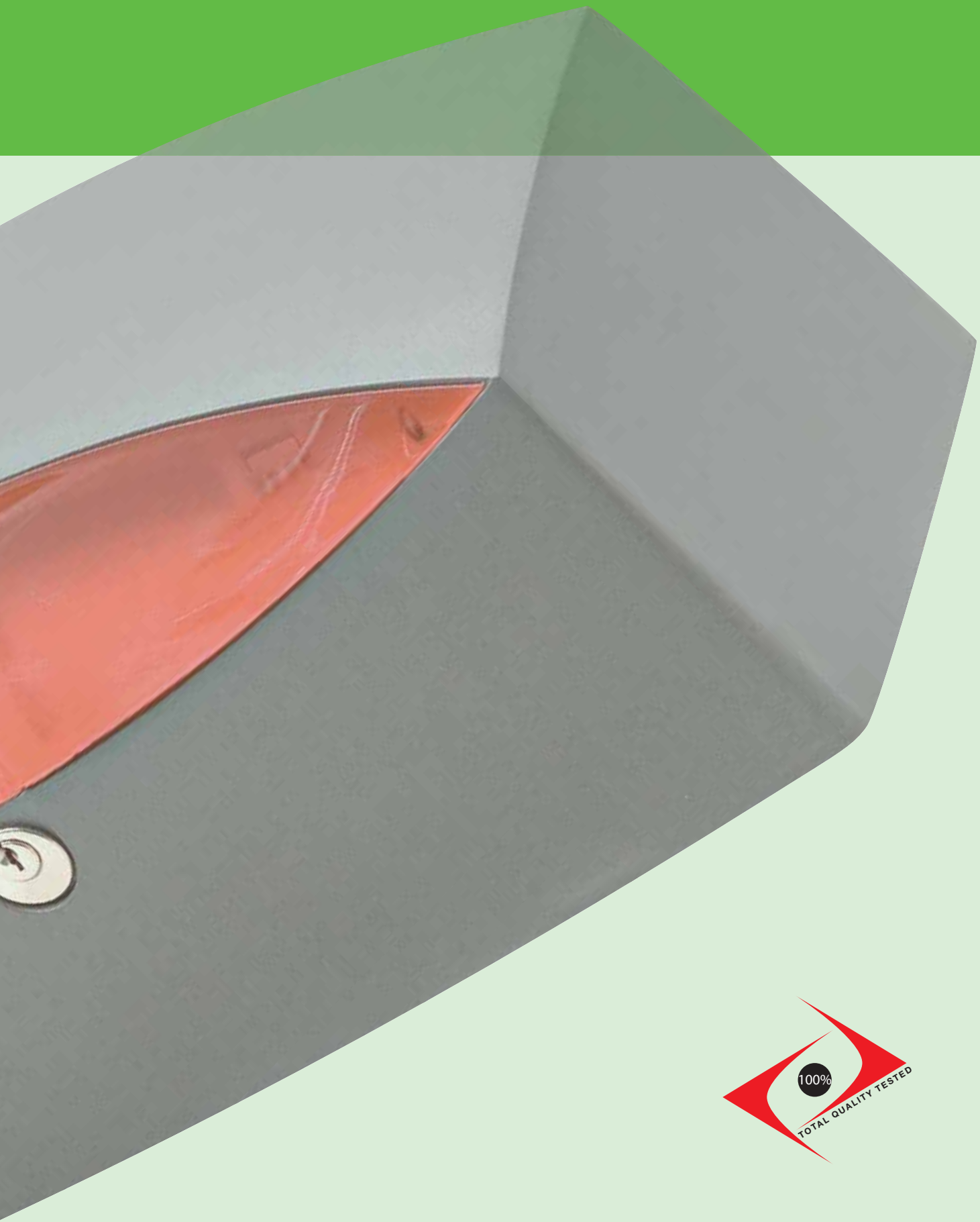

Automation for book doors





SINUO DOOR

Automation for book doors



Automation for book doors

Sinuo Door automation for Doors up to 1.5 meters satisfies every need. Proposed in 230V version to reach the highest security levels. Combines the maximum benefit duration and strength, with a pleasant contemporary design. This is supported by a design and manufacturing of high-level, in line with the standards of quality, design and features the most advanced in the contemporary scene.

Projected to last

From the very start right up to the finished product, the **Sinuo** smodels are studied in every details and assessed to ensure that the highest performance are reached and maintained. The structure of two hulls is press fused aluminium: the top of the lightness and the unalterability. The right thickness and the precise construction of the hulls ensure a stability and strength able to overcome each type of test. Particular attention has been made to the construction of the reduction gear' mechanics, which permit a silent rotation.



Functionality first of all

LIFE think everything to improve the customer's life, as well as making the installation easier for the engineer/installors. From the protective shell removable, thanks to two screws in easily accessible position, until the release device. Even if it is rarely used anticipated, the mechanical unblock system has been designed to be effective with the maximum security and safety. One last comfort.

Simplicity first of all

LIFE knows the practical needs of installers: that's why has studied every detail to make it easy, fast and rewarding their work. The assembly instructions are clever and in a simple step by step format. This makes for perfect results and ultimately saves time: another advantage of the products **LIFE**. Besides a complete range of solutions, there is also a range of technical and commercial custom services.

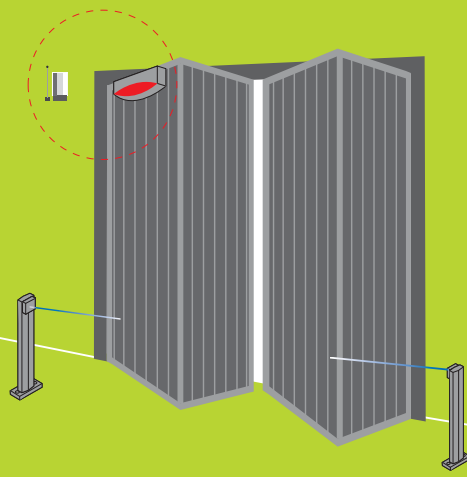

SINUO DOOR

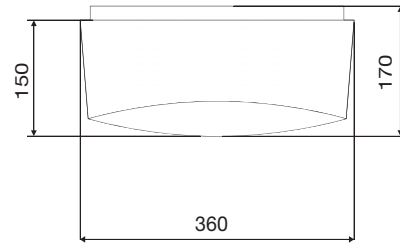
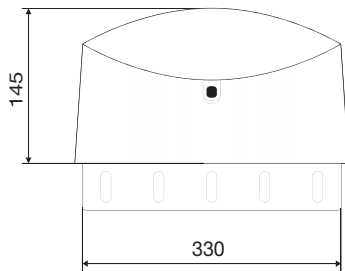

Irreversible Electromechanical gear motor for book doors.

Code	Door	Motor	Description	Pcs / Pallet	€ / Pcs
SIN DOOR	1,5 m	230V a.c.	Irreversible electromechanical gear motor with opening and closing limit switches. Central command unit not integrated on board.	20	449,00

		SINU DOOR
Max weight wing (see graphic)	kg	250
Max length wing (see graphic)	m	1,5
Power supply	V	230 50 Hz
Power	W	220
Pair	Nm	350
Working temperature	°C Min/Max	-20 +70
Protection Level	IP	44
Intermittence work cycle	%	30
Speed	rpm	1,7
Protection live	°C	140

Limit use SINU DOOR

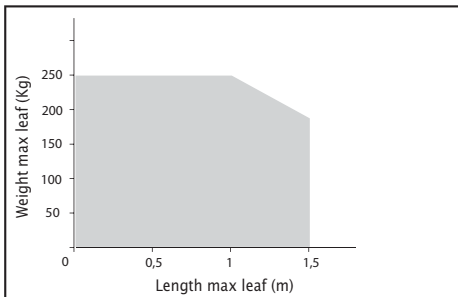

Reduce Limit use in case of windy area, or particular structural shape of the gate.

ASEC SIN € / Pcs 99,00



Internal Unblocking with 6 mt. cable
(Pcs/Box 1)

ASECAR XL € / Pcs 39,00



Internal Unblocking with 6 mt. cable
(Pcs/Box 1)

DOS € / Pcs 99,00



Key selector to release mechanically the lock.
(Pcs/Box 1)

GE UNI R € / Pcs 239,00



Control Unit.
(Pcs/Box 1)

TL € / Pcs 2,90



Warning sign.



MADE IN ITALY

TENAX

Automation for rolling shutters



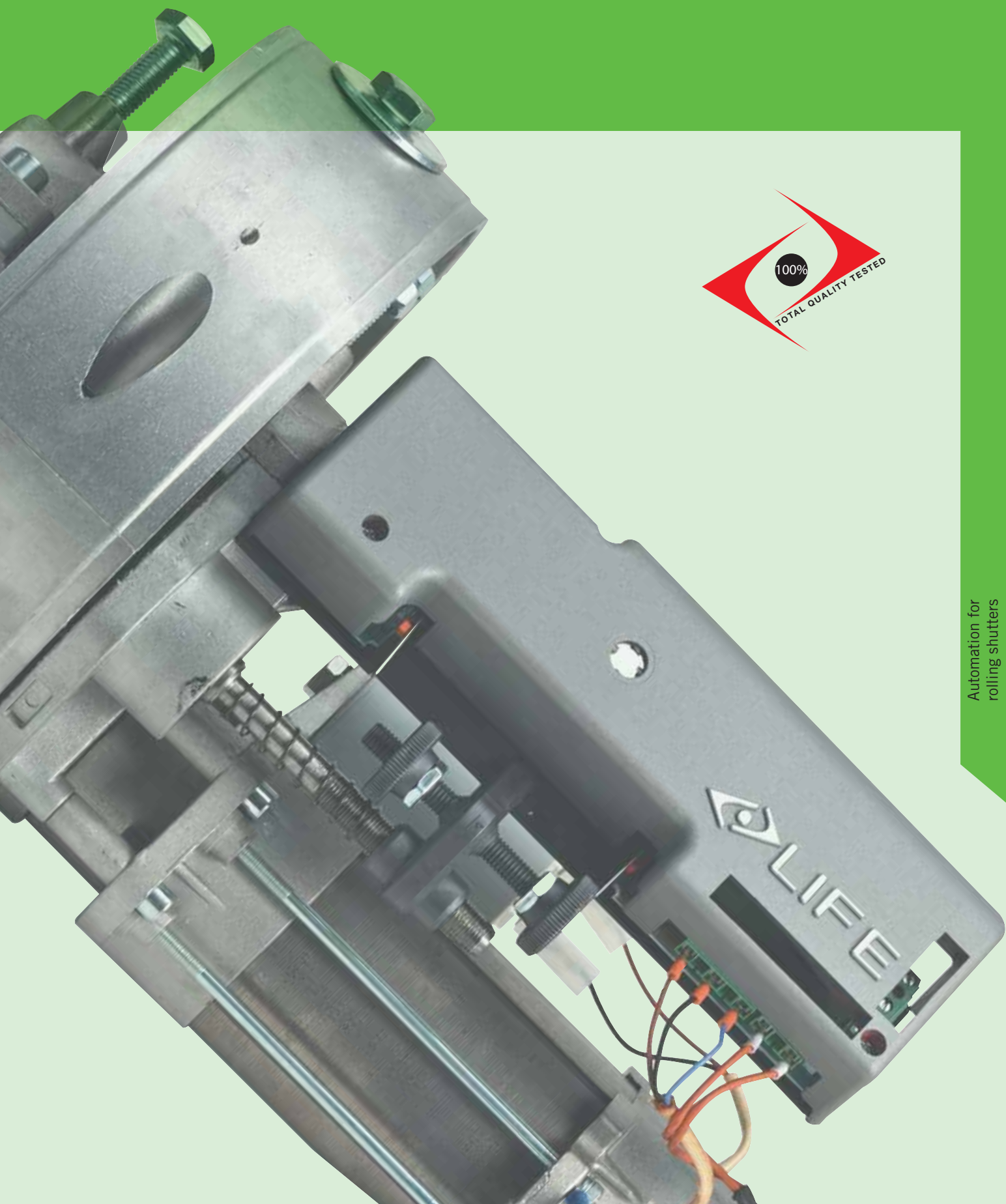

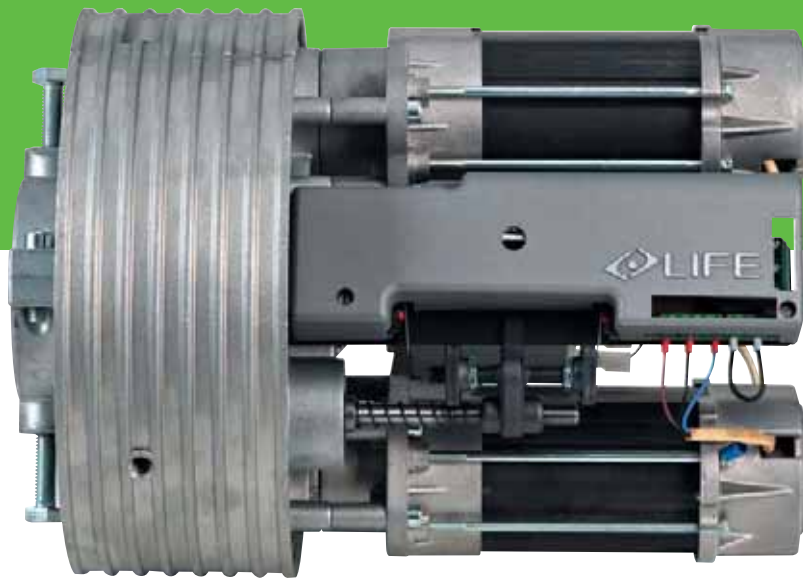

TENAX

Automation for rolling shutters



Automation for rolling shutters

From the initial design to the finished product the **Tenax** models are studied in the minutes detail, to guarantee the best performances over time. The structure is aluminum die cast to high density: the top of the lightness and the unalterability. The right thickness and the precise construction of the shells provide stability and strength can overcome any trial. Attention to detail in the mechanical construction ensures silent operation.

Total Reliability

The **LIFE** quality is born already in phase of planning, guaranteed from use of the best members beyond that from un' taken care of realization, and it is certified from the marks of more prestigious qualities, in the respect of the international norms. The emergency of the **LIFE** products is applied to all fields, a philosophy that is based on the requirements of the customer and on the protection of your job for being effective in every condition, what do you ask more from life?



Emergency to All Field

The **LIFE** the emergency is a fundamental value that comes expressed to 100% in every solution: in the prevention of every disadvantage, thanks to sophisticated electronic systems, at the inaccessibility of the codes of remote control, in the innovative robustness of the materials and at last in the duration and reliability, that they safeguard in the time the investment of the customer.

Fast Installation

There are three steps in order to shape the installation. An intelligent instrument that can always find an answer and solution in every requirement of installation. Clear, simple and intuitive, the instructions of assembly contribute to reduce the times of installation. With the personalised quality, design and service of **LIFE**, you will catch up the highest technical levels and satisfaction.

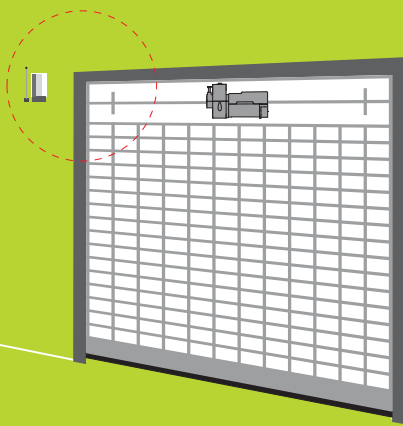

TENAX

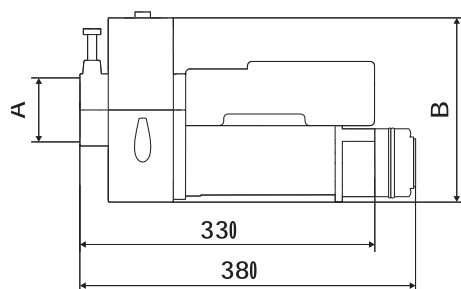

	A (mm)	B (mm)
TENAX 120 TENAX 120F TENAX 160 TENAX 160F	60	200
TENAX 210 TENAX 210F TENAX 420 TENAX 420F	76	240

Central gear motor for rolling shutters.

Code	Pair (Nm)	Motor	Description	Pcs / Pallet	€ / Pcs
TENAX 120	120	230V a.c.	Reversible gear motor without a brake function. Raising force 120 kg.	21	209,00
TENAX 120 F	110	230V a.c.	Irreversible gear motor with a brake function. Raising force 120 kg.	21	259,00
TENAX 160	160	230V a.c.	Reversible gear motor without a brake function. Raising force 160 kg.	21	229,00
TENAX 160 F	150	230V a.c.	Irreversible gear motor with a brake function. Raising force 160 kg.	21	279,00
TENAX 210	210	230V a.c.	Reversible gear motor without a brake function. Raising force 180 kg.	21	319,00
TENAX 210 F	190	230V a.c.	Irreversible gear motor with a brake function. Raising force 180 kg..	21	369,00
TENAX 420	420	230V a.c.	Reversible gear motor without a brake function. Raising force 360 kg.	21	489,00
TENAX 420 F	380	230V a.c.	Irreversible gear motor with a brake function. Raising force 360 kg.	21	539,00

		TENAX 120	TENAX 120F	TENAX 160	TENAX 160F	TENAX 210	TENAX 210F	TENAX 420	TENAX 420F
Pair	Nm	120	110	160	150	210	190	420	380
R.P.M.		10	10	10	10	8	8	8	8
Nr fi ne turns run		5-6	5-6	5-6	5-6	5-6	5-6	5-6	5-6
Before thermal time	min	4	4	4	4	4	4	4	4
Absorbed power	W	460	460	630	630	630	630	1260	1260
Absorbed intensity	A	2.2	2.2	2.7	2.7	2.7	2.7	5.4	5.4
Weight	Kg	7	8	8	9	9	10	16	17
Raising	Kg	120	120	160	160	180	180	360	360
Tree Shutter	mm	60	60	60	60	76	76	76	76
Gear	mm	200	200	200	200	240	240	240	240

ASECAR XL € / Pcs 39,00



External unblocking device with metallic cable.
(Pcs/Box 1)

DOS € / Pcs 99,00



Key selector to release mechanically the lock.
(Pcs/Box 1)

TEN 33 € / Pcs 9,00



Tube Adapter of Ø 33 millimeter.
(Pcs/Box 1)

TEN 42 € / Pcs 10,00



Tube Adapter of Ø 42 millimeter.
(Pcs/Box 1)

TEN 48 € / Pcs 11,00



Tube Adapter of Ø 48 millimeter.
(Pcs/Box 1)

GE UNI R € / Pcs 239,00



Control unit.
(Pcs/Box 1)

GE UNI EASY € / Pcs 109,00

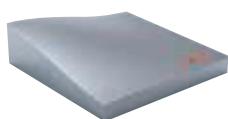

Control Unit.
(Pcs/Box 1)

TL € / Pcs 2,90



Warning sign.



MADE IN ITALY

GEBOX

Control boards with microprocessor





Control boards
Radio control systems



GEBOX

Control boards with microprocessor



Control boards

LIFE solves in a unique way the many requirements of domestic automation: starting from control board **Gebox**. **Gebox** and **Gebox** Digital Life Technology represent a range of specific solutions for the management of automatic gates, with 230 or 24V SUPPLY, that can be either installed separately or directly integrated to the motor. These versatile “brains” allow a complete adjustment of all the opening / closing functions; more, they also take care of the user safety, interacting with the encoder, supplied with all **LIFE** motors. All this with the maximum easiness, a fascinating design and an outstanding hardware. If **Gebox** and **Gebox** Digital Life Technology didn't exist it should invent them!

Functionality made to measure

With **Gebox**, programming the motor functions is extremely simple. In order to make things easy for the operator, the **LIFE Gebox** Control Board allows you to adjust the functioning parameters through a practical and ergonomic keyboard, integrated by a range of warning lights that indicate the programming state. For example, one can determine an interval between opening and closing, or modulate the electromechanical power, sensitivity of safety devices, automatic, semiautomatic or manual functioning, partial pedestrian opening... and much more. For installations that don't require any particular function, **LIFE** has thought the two preset user modes that make it all, even simpler: once installed, **Gebox** is immediately ready for use.



Quality at first sight

Rain, frost, direct sunlight... **Gebox** fears nothing, because it's been developed to **LIFE's** research for quality. Manufactured with resistant plastic materials, the shell is waterproof and guarantees a perfectly operative working cycle even in the presence of extreme weather conditions, from -20°C up to + 70°C. Strong under any circumstance, **Gebox** is also aesthetically appealing, because **LIFE** is always updated with the latest trends, not only in technology, but also when it comes to appearance.



Perfect and quick installation

LIFE solves the installers requirements starting from the project easy phases: the box is already equipped with transformer and batteries, accordingly to the chosen power supply. Five predisposed drills for cable passage have already been configured in the lower part of the box. Moreover, the shell is equipped with specific rotating plastic fillers in order to hide and protect the fixing screws. As well as all **LIFE** products, **Gebox** is equipped with complete and simple assembling instructions: **LIFE** knows how to improve your life.



GEBOX

Control boards with microprocessor

Code	n° motor	Motor	Description	€ / Pcs
GE1A 24	1	24V d.c.	IP55 box and control for LIFE gear motors with embodied optical encoder, with or without limit switches. Predisposed for insertion of LIFE radio receivers and battery charging circuit.	179,00
GE2A 24	1 ÷ 2	24V d.c.	IP55 box and control unit with for LIFE gear motors with embodied with or without limit switches. Predisposed for insertion of LIFE radio receivers and battery charging circuit.	279,00
* GE UNI 24R DL	1 ÷ 2	24V d.c.	IP55 box and control unit for LIFE gear motors with embodied optical encoder. Receiver radius 433,92 integrated MHz LIFE	269,00
				
GE1A	1	230V a.c.	IP55 box and control unit for LIFE gear motors with embodied optical encoder, with or without limit switches. Predisposed for insertion of LIFE radio receivers. Electrical setting of the clutch.	169,00
GE2A	1 ÷ 2	230V a.c.	IP55 box and control unit for LIFE gear motors with embodied optical encoder, with or without limit switches. Predisposed for insertion of LIFE radio receivers. Electrical setting of the clutch.	199,00
GE2R	1 ÷ 2	230V a.c.	IP55 box and control unit for LIFE gear motors with embodied optical encoder, with or without limit switches. LIFE 433,92 Mhz radio receiver onboard and extractable code memory storage. Electrical setting of the clutch.	199,00
* GE UNI R	1 ÷ 2	230V a.c.	IP55 box and control unit for LIFE gear motors, with or without limit switches. LIFE 433,92 MHz radio receiver on board and extractable code memory storage. Electrical setting of the clutch.	239,00
* GE UNI R S DL	1 ÷ 2	230V a.c.	IP55 box and control unit for LIFE gear motors, without limit switches. LIFE 433,92 MHz radio receiver on board Electrical setting of the clutch. Amperometric detection of the input current	239,00
				
* GE UNI EASY	1	230V a.c.	Box IP44 command of motor reducer with or without limit switch. Receiver radius 433,92 integrated MHz LIFE Recommended for shutters, blinds and curtains	109,00

* Control board series UNI, without encoder

Main features of control boards

	230 Vac 50Hz								24 V					
	GE1A RG1A	GE VIS R DL RG VIS R DL	RG1R DL	GE UNI EASY RG UNI EASY	GE2A RG2A	GE2R RG2R	GE UNI R RG UNI R	GE UNI RS DL RG UNI RS DL	GE1A 24 RG1A 24	RG1 24P DL	RG1R 24DL	GE2A 24 RG2A 24	GE UNI 24R DL RG UNI 24R DL	RG UNI 24R DL AR
Command one motor	•	•	•	•	•	•	•	•	•	•	•	•	•	•
Command one and two motors					•	•	•	•				•	•	•
Electric torque adjustment	•				•									
Electronic torque adjustment		•	•			•	•				•	•	•	•
Connection for radio receivers	•				•						•			
Radio receiver integrated 433,92 Mhz		•	•	•		•	•				•	•	•	•
Obstacle detection	•	•	•		•	•	•		•	•	•	•	•	•
Opening limit switch	•	•	•	•	•	•	•		•	•	•	•	•	•
Closing limit switch	•	•	•	•	•	•	•		•	•	•	•	•	•
Analog photocells	•	•	•	•	•	•	•		•	•	•	•	•	•
Battery charger AGECH									•	•		•	•	•

Scheme using control units with engines

	230 Vac 50Hz								24 V					
	GE1A RG1A	GE VIS R DL RG VIS R DL	RG1R DL	GE UNI EASY RG UNI EASY	GE2A RG2A	GE2R RG2R	GE UNI R RG UNI R	GE UNI RS DL RG UNI RS DL	GE1A 24 RG1A 24	RG1 24P DL	RG1R 24DL	GE2A 24 RG2A 24	GE UNI 24R DL RG UNI 24R DL	RG UNI 24R DL AR
OP224 UNI														
OP324									•					
OP3 SL UNI							•	•						
OP3	•													
OP3 UNI - OP3 UNI L								•	•					
OP524									•					
OP5	•					•	•							
OP5 UNI - OP5 UNI L								•	•					
SETUP OP3 - OP5 UNI DL								•	•					
SETUP OP3 SL UNI DL								•	•					
SETUP OP224 UNI DL													•	
AR224P UNI DL														•
SETUP ARMOR UNI DL														•
SIN 3 UNI								•	•					
SIN 5 UNI								•	•					
ER424											•			
ER4 - ER4 B - ER4 L	•					•	•							
ER4 UNI - ER4 UNI L								•	•					
AC6M	•													
AC4R - AC6R - AC8R - AC12R DL			•											
AC4RM - AC6RM - AC8RM - AC12RM DL			•											
AC3RM 24DL - AC6RM 24DL										•				
SETUP AC4R DL - AC4RM DL			•											
SETUP AC6R DL - AC6RM DL			•											
SETUP AC8R DL - AC8RM DL			•											
SETUP AC12R DL - AC12RM DL			•											
SETUP AC3RM 24DL - AC6RM 24DL										•				
SU4 24									•					
PR70-DL										•				
PR120-DL										•				
PL1 - PL1L	•													
SETUP PLUS	•													
VIS		•												
SIN DOOR								•	•					
TENAX				•				•	•					

AGECH € / Pcs 49,00



Battery charger additional circuit for control boards (see table at page 94) (Pcs/Box 1)

AGE12 € / Pcs 120,00



Battery 12V - 2,3 Ah. (Pcs/Box 2)

GEBOX € / Pcs 39,00



Box IP55. (Pcs/Box 1)

TL € / Pcs 2,90



Warning Sign.

FAST R2 € / Pcs 36,00



Two channel radio receiver on 433,92 Mhz frequency 1000 codes memory storage integrated. Module to be inserted. "LIFE Rolling code" and "Auto Code" coding systems. (Pcs/Box 1)

EVER R2 € / Pcs 44,00



Two channels on frequency 868,35 MHz frequency 1000 codes memory storage integrated. Module to be inserted. "LIFE Rolling code" and "Auto Code" coding systems. (Pcs/Box 1)



MADE IN ITALY

VIPR-OMNIS-VIP-FIDO-STAR

Radio control systems



BRAVO-EVER-BSM





VIPR-OMNIS

Radio control systems



VIPR: quality to show off

The versatility and innovation of **LIFE** "home integration" has upgraded the sector's scene and is with you anywhere, with transmitters **Vipr, Fido, Star, Bravo** and **Ever**. Solid and very simple to use, these transmitters combine charming looks and avant-garde technology, allowing you to manage a full range of functions with maximum comfort and total safety. Just a touch of the hand and a new world of authentic avails opens up, exclusively to the owners of **LIFE** Systems.



OMNIS:





This new system allows the management and the personalization of the plants through the aid of a software installed on Pc and a portable programmer. For the management it must use the transmitters of **VIP2R** and **VIP4R** series, while all the receivers actually in our production can be managed. Each programmer will be able to manage more than 10.000 systems, a variety of 950 remote controls for a two channel receiver and 750 for a four channel receiver.



	VIP2R	VIP4R
N° channels	2	4
Type codifies	Rolling-Code	
Carrying frequency	433,92 MHz	
Irradiated power	1 mW	
Codifies	64 Bit	
Feeding	6 V	
Temperature max	55 °C	
Capacity on receivers LIFE	150-200 m	

VIPR

Emitter radius LIFE ROLLING 433,92 TAILS MHZ.

	Code	Description	€/Pcs
	VIP2R	Two channel radio transmitter on 433,92 Mhz frequency. "LIFE Rolling code" coding system. Two 3V CR2032 lithium batteries included.	29,00
	VIP4R	Four channel radio transmitter on 433,92 Mhz frequency. "LIFE Rolling code" coding system. Two 3V CR2032 lithium batteries included.	32,00
	FAST R2	Two channel radio receiver on 433,92 Mhz frequency 1000 codes memory storage integrated. Module to be inserted. "LIFE Rolling code" and "Auto Code" coding systems.	36,00
	FAST R1E	One channel radio receiver with 750 codes memory storage integrated. Clamp output with an NO relay with four functioning modes: monostable, bistable, 30 sec. and 180 sec. temporisation. Antenna input and power supply input 12÷24V ac÷dc.	68,00
	FAST R2E	Two channel radio receiver with 750 codes memory storage integrated. Clamp output with two NO relays with four functioning modes: monostable, bistable, 30 sec. and 180 sec. temporisation. Antenna input and power supply input 12÷24V ac÷dc.	76,00
	FAST R4E	Four channel radio receiver with 750 codes memory storage integrated. Clamp output with four NO relays with four functioning modes: monostable, bistable, 30 sec. and 180 sec. temporisation. Antenna input and power supply input 12÷24V ac÷dc.	109,00
	SKANT	Matching antenna and coaxial cable. Stainless steel fixing bracket.	19,00



OMNIS

Programmatore per gestione telecomandi

Code	Description	€/Pcs
OMNIS	Hand held programmer, 799 retro – illuminated display. Internal memory capacity for 20 individual systems and 1,000 codes. Connection cable, USB Software on CD rom.	799,00





VIP-FIDO

Radio control systems



VIP: quality to show off

The versatility and innovation of **LIFE** “home integration” has upgraded the sector’s scene and is with you anywhere, with transmitters **Vipr, Fido, Star, Bravo** and **Ever**. Solid and very simple to use, these transmitters combine charming looks and avant-garde technology, allowing you to manage a full range of functions with maximum comfort and total safety. Just a touch of the hand and a new world of authentic avails opens up, exclusively to the owners of **LIFE** Systems.



FIDO: quality that distinguish

LIFE puts the utmost care into every detail that may contribute to better the quality of its products and the easiness in using them. A perfect synthesis of aesthetics, ergonomics and functionality, the design of these transmitters adds elegance and practicality to everyday life. The protection shell, manufactured in a solid and resistant plastic, assures a perfect functioning under any condition. The 12V batteries assure long life and the reach satisfies any usage requirement.



	VIP2	VIP4
N° chanel	2	4
Type codifies	Rolling-Code	
Carrying frequency	433,92 MHz	
Irradiated power	1 mW	
Codifies	64 Bit	
Feeding	6 V	
Temperature max	55 °C	
Capacity on receivers LIFE	150-200 m	

VIP

Emitter radius LIFE ROLLING 433,92 TAILS MHZ.



Code	Description	€/Pcs
VIP2	Two channel radio transmitter on 433,92 Mhz frequency. "LIFE Rolling code" coding system. Two 3V CR2032 lithium batteries included.	28,00



VIP4	Four channel radio transmitter on 433,92 Mhz frequency. "LIFE Rolling code" coding system. Two 3V CR2032 lithium batteries included.	31,00
-------------	--	--------------



FAST R2	Two channel radio receiver on 433,92 Mhz frequency 1000 codes memory storage integrated. Module to be inserted. "LIFE Rolling code" and "Auto Code" coding systems.	36,00
----------------	---	--------------

FAST R1E	One channel radio receiver with 750 codes memory storage integrated. Clamp output with an NO relay with four functioning modes: monostable, bistable, 30 sec. and 180 sec. temporisation. Antenna input and power supply input 12÷24V ac÷dc.	68,00
-----------------	--	--------------



FAST R2E	Two channel radio receiver with 750 codes memory storage integrated. Clamp output with two NO relays with four functioning modes: monostable, bistable, 30 sec. and 180 sec. temporisation. Antenna input and power supply input 12÷24V ac÷dc.	76,00
-----------------	--	--------------

FAST R4E	Four channel radio receiver with 750 codes memory storage integrated. Clamp output with four NO relays with four functioning modes: monostable, bistable, 30 sec. and 180 sec. temporisation. Antenna input and power supply input 12÷24V ac÷dc.	109,00
-----------------	--	---------------







SKANT	Matching antenna and coaxial cable. Stainless steel fixing bracket.	19,00
--------------	---	--------------



	FID02	FID04
N° chanel	2	4
Type codifies	Rolling-Code	
Carrying frequency	433,92 MHz	
Irradiated power	1 mW	
Codifies	64 Bit	
Feeding	12 V	
Temperature max	55 °C	
Capacity on receivers LIFE	150-200 m	

FIDO

Emitter radius LIFE ROLLING 433,92 TAILS MHz.

Code	Description	€ / Pcs
 FID02	Two channel radio transmitter on 433,92 Mhz frequency "LIFE Rolling code" coding system. 12V alkaline battery.	27,00
 FID04	Four channel radio transmitter on 433,92 Mhz frequency "LIFE Rolling code" coding system. 12V alkaline battery.	29,00
 FAST R2	Two channel radio receiver on 433,92 Mhz frequency 1000 codes memory storage integrated. Module to be inserted. "LIFE Rolling code" and "Auto Code" coding systems.	36,00
FAST R1E	One channel radio receiver with 750 codes memory storage integrated. Clamp output with an NO relay with four functioning modes: monostable, bistable, 30 sec. and 180 sec. temporisation. Antenna input and power supply input 12÷24V ac÷dc.	68,00
 FAST R2E	Two channel radio receiver with 750 codes memory storage integrated. Clamp output with two NO relays with four functioning modes: monostable, bistable, 30 sec. and 180 sec. temporisation. Antenna input and power supply input 12÷24V ac÷dc.	76,00
FAST R4E	Four channel radio receiver with 750 codes memory storage integrated. Clamp output with four NO relays with four functioning modes: monostable, bistable, 30 sec. and 180 sec. temporisation. Antenna input and power supply input 12÷24V ac÷dc.	109,00
 SKANT	Matching antenna and coaxial cable. Stainless steel fixing bracket.	19,00



STAR-BRAVO

Radio control systems



STAR: **A touch of simplicity**

LIFE widens its range of transmitters and offers a new software protocol to simplify the code self-programming from one transmitter to another.

Without involving any other tool, but just by following a simple “plug & play” procedure, it is possible to differentiate a countless amount of transmitters.



BRAVO: **Friendly technology**

LIFE puts the utmost care into every detail that may contribute to better the quality of its products and the easiness in using them.

A perfect synthesis of aesthetics, ergonomics and functionality, the design of these transmitters adds elegance and practicality to everyday life. The protection shell, manufactured in a solid and resistant plastic, assures a perfect functioning under any condition.





The 6-12V batteries assure long life and the reach satisfies any usage requirement.



	STAR2	STAR4
N° chanel	2	4
Type codifies	Auto-Code	
Carrying frequency	433,92 MHz	
Irradiated power	1 mW	
Codifies	32 Bit	
Feeding	6 V	
Temperature max	55 °C	
Capacity on receivers LIFE	150-200 m	

STAR

Emitter LIFE CAR 433,92 TAILS MHz

	Code	Description	€ / Pcs
	STAR2	Two channel radio transmitter on 433,92 Mhz frequency "LIFE Auto Code" coding system. 12V alkaline battery.	29,00
	STAR4	Four channel radio transmitter on 433,92 Mhz frequency "LIFE Auto Code" coding system. 12V alkaline battery.	32,00
	FAST R2	Two channel radio receiver on 433,92 Mhz frequency 1000 codes memory storage integrated. Module to be inserted. "LIFE Rolling code" and "Auto Code" coding systems.	36,00
	FAST R1E	One channel radio receiver with 750 codes memory storage integrated. Clamp output with an NO relay with four functioning modes: monostable, bistable, 30 sec. and 180 sec. temporisation. Antenna input and power supply input 12÷24V ac÷dc.	68,00
	FAST R2E	Two channel radio receiver with 750 codes memory storage integrated. Clamp output with two NO relays with four functioning modes: monostable, bistable, 30 sec. and 180 sec. temporisation. Antenna input and power supply input 12÷24V ac÷dc.	76,00
	FAST R4E	Four channel radio receiver with 750 codes memory storage integrated. Clamp output with four NO relays with four functioning modes: monostable, bistable, 30 sec. and 180 sec. temporisation. Antenna input and power supply input 12÷24V ac÷dc.	109,00
	SKANT	Matching antenna and coaxial cable. Stainless steel fixing bracket.	19,00



	BRAVO2	BRAVO4
N° chanel	2	4
Code type	Auto-Code	
Carrying frequency	433,92 MHz	
Irradiated power	1 mW	
Codifies	32 Bit	
Feeding	12 V	
Temperature max	55 °C	
Capacity on receivers LIFE	150-200 m	

BRAVO

Emitter LIFE CAR 433,92 TAILS MHZ.

Code	Description	€ / Pcs
BRAVO2	Two channel radio transmitter on 433,92 Mhz frequency "LIFE Auto Code" coding system. 12V alkaline battery.	27,00
BRAVO4	Four channel radio transmitter on 433,92 Mhz frequency "LIFE Auto Code" coding system. 12V alkaline battery.	29,00
FAST R2	Two channel radio receiver on 433,92 Mhz frequency 1000 codes memory storage integrated. Module to be inserted. "LIFE Rolling code" and "Auto Code" coding systems.	36,00
FAST R1E	One channel radio receiver with 750 codes memory storage integrated. Clamp output with an NO relay with four functioning modes: monostable, bistable, 30 sec. and 180 sec. temporisation. Antenna input and power supply input 12÷24V ac÷dc.	68,00
FAST R2E	Two channel radio receiver with 750 codes memory storage integrated. Clamp output with two NO relays with four functioning modes: monostable, bistable, 30 sec. and 180 sec. temporisation. Antenna input and power supply input 12÷24V ac÷dc.	76,00
FAST R4E	Four channel radio receiver with 750 codes memory storage integrated. Clamp output with four NO relays with four functioning modes: monostable, bistable, 30 sec. and 180 sec. temporisation. Antenna input and power supply input 12÷24V ac÷dc.	109,00
SKANT	Matching antenna and coaxial cable. Stainless steel fixing bracket.	19,00





EVER-BSM

Radio control systems



EVER: new classified codes

The **LIFE** range of transmitters offers a new type of coding, inaccessible to strangers. The **LIFE** Rolling Code changes at every use, following a pre-defined sequence and a sophisticated algorithm that inhibits duplication or copying. The protective shell is made of very resistant plastic, and guarantees a perfect functioning under any weather condition. The 12V batteries assure long-life, and the reach satisfies any using requirement.



BSM: quicker installation, easier maintenance





LIFE has considered everything in order to better the life of its end users, but at the same time making the job simpler for technicians and installers. The sensitive edge is composed by a 30 mm rubber profile with an elastic antiimpact end-of-run cushion and by an aluminium profile fixed to the column or the gate that supports the rubber extrusion. The device functioning is guaranteed by two micro-switches, one operating on the rubber bending and the lower support, the second one operates as a safety device in the case the steel cable should lose tension. And with **LIFE**'s quality, design and customized services. It is even easier to enter a real new world of benefit.



	EVER2	EVER4
N° channels	2	4
Code type	Rolling-Code	
Carrying frequency	868,35 MHz	
Irradiated power	1 mW	
Codifies	64 Bit	
Feeding	6 V	
Temperature max	55 °C	
Capacity on receivers LIFE	150-200 m	

EVER

Transmitters LIFE ROLLING CODE 868,35 MHz.

	Code	Description	€ / Pz.
	EVER2	Two channel radio transmitter on 868,35 Mhz frequency "LIFE Rolling code" coding system. Two 3V CR 2032 lithium batteries.	31,00
	EVER4	Four channel radio transmitter on 868,35 Mhz frequency "LIFE Rolling code" coding system. Two 3V CR 2032 lithium batteries.	34,00
	EVER R2	Two channel radio receiver on 868,35 Mhz frequency 1000 codes memory storage integrated. Module to be inserted. "LIFE Rolling code" and "Auto Code" coding systems.	44,00
	EVER R1E	One channel radio receiver with 750 codes memory storage integrated. Clamp output with an NO relay with four functioning modes: monostable, bistable, 30 sec. and 180 sec. temporisation. Antenna input and power supply input 12÷24V a.c./d.c.	69,00
	EVER R2E	Two channel radio receiver with 750 codes memory storage integrated. Clamp output with two NO relays with four functioning modes: monostable, bistable, 30 sec. and 180 sec. temporisation. Antenna input and power supply input 12÷24V ac÷dc.	79,00
	EVER R4E	Four channel radio receiver with 750 codes memory storage integrated. Clamp output with four NO relays with four functioning modes: monostable, bistable, 30 sec. and 180 sec. temporisation. Antenna input and power supply input 12÷24V ac÷dc.	109,00
	SKANT	Matching antenna and coaxial cable. Stainless steel fixing bracket.	19,00



BSM

Pre-assembled sensitive edge.

Code	Description	€ / Pcs
BSM15	Mechanical contact sensitive edge, mounted on aluminium profile. L=150 cm.	79,00
BSM17	Mechanical contact sensitive edge, mounted on aluminium profile. L=170 cm.	84,00
BSM20	Mechanical contact sensitive edge, mounted on aluminium profile. L=200 cm.	89,00
BSM25	Mechanical contact sensitive edge, mounted on aluminium profile. L=250 cm.	99,00

PRL	Radio link LIFE	329,00
------------	-----------------	---------------



SM1	Single-channel magnetic sensor for detection of metal.	299,00
------------	--	---------------





MADE IN ITALY

DES-DESE-DIXES-VISIO

Photocells and selectors with supports and columns



VIRE-REX

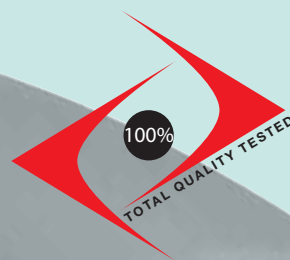



DES-DESE-DIXES Key selectors - Digital Selector



DES-DESE: quality to show off

Those looking at the future of “home integration” choose **LIFE**: a new leader in quality and technology, with a range of solutions introducing avant-garde concepts and benefits. The presence detecting system, composed by **Des** and **Dese** selectors and Rex supporting columns, represents a new reference point in the business sector, due to its efficacy, flexibility, safety and easiness to install.

With **LIFE** a new era has started for automation, under every point of view.



DIXES: quality that distinguish

Those looking to the future of “home integration” choose **LIFE**: a new leader in quality and technology, with a range of solutions introducing avant-garde concepts and benefits.

The Rolling Code remote control system, formed by the **Dixes** selector with ergonomic keypad and the **Dix**, decoder represent a new reference point in the business sector: due to its efficacy, flexibility, safety and easiness to use. With **LIFE** has started a new era of automation under every point of view.



	DES	DESE
Cylinder bolt	Universale	Europeo
N° positions	2 ± 90°	2 ± 90°
Protection level	IP54	IP54
Contacts type	Nc+No	Nc+No
Reach max contacts	<2A;	<42V a.c./d.c.
Temperature min/max	-20 +55 °C	-20 +55 °C
Dimension mm	65x80x40	65x80x40

DES-DESE

Key selectors.

Code	Description	€ / Pcs
DES	Key selectors. Normal bolt. External application. Aluminium casing.	33,00
DIN	Key selectors. Normal bolt. External application. Wall-mount application to be combined with AREC box.	30,00
DESE	Key selectors. European bolt. External application. Aluminium casing.	38,00
DINE	Key selectors. European bolt. Aluminium casing. Wall-mount application to be combined with AREC box.	36,00
AREC	Wall-insert box for photocells, selector and digital keyboards.	(Pcs/Box 10) 20,00
AREF	Supporting bracket for photocells, selectors and digital keyboards.	(Pcs/Box 4) 20,00
ALED	Indication light for key selectors.	(Pcs/Box 5) 40,00
ALEP	Fixing interface for photocells, selectors and digital keyboards when different wall fittings are in use.	(Pcs/Box 4) 16,00

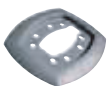
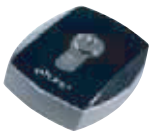
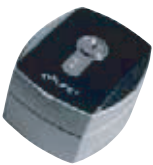



Description	DIXES	DIX
	Selettore	Decoder
Supply	12÷20V d.c.	12÷24V a.c.
Absorption max	50 mA	50 mA
Protection level	IP54	IP30
N° contacts type	-	4 x No
Contact capacity max	-	50 x 50 mA
Temperature min/max	-20 +55°C	-20 +55°C
Dimension (Visio) mm	65x83x41	77x59x24

DIXES

Digital Selector

Code	Description	€ / Pcs
DIXES	Keyboard selector. Digital Key. External application. Aluminium casting and metal key buttons. To be combined with Dix decoder.	76,00
DIXIN	Keyboard selector. Digital key Wall-mount application. To be combined with AREC box. Alluminium. Casing and metal key buttons. To be combined with DIX Decoder.	74,00
DIX	Decoder for keyboard selector with 750 code memory storage. Clamp output with 4 relays with 4 functioning modes.	79,00
AREC	Wall-insert box for photocells, selector and digital keyboards.	(Pcs/Box 10) 20,00
AREF	Supporting bracket for photocells, selectors and digital keyboards.	(Pcs/Box 4) 20,00
ALEP	Fixing interface for photocells, selectors and digital keyboards when different wall fittings are in use.	(Pcs/Box 4) 16,00





VISIO-VIRE-REX

Photocells with supports and columns



VISIO-VIRE: safety in real time

Those looking to the future of “home integration” choose **LIFE**: a new leader in quality and technology , with a range of solutions introducing avant-garde concepts and benefits.

The presence detection system, formed by the relay synchronized **Visio** photocells, by the photocells with Digital Life Technology and by all the supporting accessories represent a new reference point in the business sector: due to its efficacy, flexibility, safety and easiness to use. With **LIFE** a new era has started for automation, under every point of view.



REX: special materials, original concepts

LIFE's quality starts already during the designing phase, and lasts throughout time. The photocells structure is in ABS, while the electronic part bears a double covering to prevent water and humidity leaks. The supporting columns, manufactured in inalterable thick aluminium, are equipped with a patented **LIFE** system that allows the revolving of the photocells with a +/- 17° excursion. Located in an aluminium die-cast box with a solid polycarbonate front, the key or keyboard selectors grant the maximum safety.



	VISIO/VIRE
Capacity	20 m
Supply	12/24V a.c.
Assorbimento Tx/Rx	25/35 mA
Absorption	IP54
Contacts type RX	Nc+No
Contact capacity max RX	1A/24 Vd.c.
Temperature min/max	-20 +55 °C
Dimension mm	64x78x26

VISIO-VIRE

Synchronized photocells.

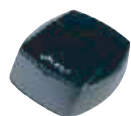

Code	Description	€/Couple
VISIO	External synchronized couple of photocells. (Couple/Box 1)	54,00

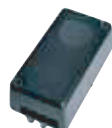

Code	Description	€/Couple
VIRE	Synchronized couple of photocells to be used exclusively inside LIFE columns REX series. Revolving $\pm 15^\circ$. (Couple/Box 1)	54,00

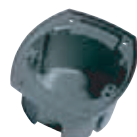

Code	Description	€/ Pcs
AREC	Wall-insert box for photocells selector and digital keyboards.	(Pcs/Box 10) 20,00



Code	Description	€/ Pcs
AREF	Supporting bracket for photocells, selectors and digital keyboards.	(Pcs/Box 4) 20,00



Code	Description	€/ Pcs
ALEP	Fixing interface for for photocells, selectors and digital keyboards when different wall fittings are in use.	(Pcs/Box 4) 16,00



REX

Columns for fotocells and Selector

Code	Description	€/Couple
RE100F	Couple of aluminium columns complete with a couple of VIRE photocells. Height 1000 mm.	179,00
		€/Pcs
RE100	Aluminium columns. Height 1000 mm. (Pcs/Box 1)	65,00
		€/Couple
RE50F	Couple of aluminium columns complete with a couple of VIRE photocells. Height 500 mm.	109,00
		€/Pcs
RE50	Couple of aluminium. Height 500 mm. (Pcs/Box 1)	30,00
		€/Pcs
RE110	Aluminium columns predisposed for selector and ARES support for installation of selectors DES, DESE, DIXES. Height 1000 mm. (Pcs/Box 1)	65,00
		€ / Pcs
ARES	Supports for insertion of a selector DES, DESE or DIXES on RE110 column.	(Pcs/Box 4) 20,00
		€ / Pcs
AREP	Fundation plates for REX series columns.	(Pcs/Box 4) 48,00





MADE IN ITALY

SPLENDOR - FULGOR

Lighting and signalling systems







SPLENDOR-FULGOR Lighting and signalling systems



SPLENDOR: installed in a flash

With Splendor, **LIFE** shines a new light in the sector of “home integration”: this is not a simple flashing light, but an avantgarde device, perfectly integrated with the other elements of domestic lighting. Moreover, its manufacturing can challenge time and weather conditions, it is easy to install, it has many versatile solutions and a modern design that qualifies the home external space, adding functionality and elegance. Another **LIFE** luminous idea, for a lifestyle even easier and comforter. The concept of Fulgor has been created through an attentive study of luminous sources, aiming to valorise and optimize what need to be illuminated, taking care of the psychological and perceptive well-being of the surrounding ambient, with attention given to shape and choice of raw materials, in order to be constantly oriented in creating a product with an essential, not intrusive design. Beyond being supplied with clear and simple instructions, Fulgor has been designed for a quick installation under any circumstance. Its essential and original appearance harmonizes perfectly with the house external and with the other **LIFE** products. For any other requirement, a full range of customized services is already available for you.



FULGOR: the future of lighting

Fulgor is the first element of a new **LIFE** project, a step towards a complete and original system of integrated illumination. **LIFE**'s technology allows to handle many various devices at the same time, with utmost easiness and quickness in connections. Due to **LIFE**'s research, it will be possible to program and control all external lighting from a distance, integrating its functioning with any other system in the house: from closing / security systems, to irrigation systems, airconditioning systems, even electrical domestic appliances. In the end, **LIFE** welcomes you to the future: starting today. To manufacture Splendor and Fulgor, **LIFE** has selected the best raw materials and has chosen a simple though solid two-piece structure, with a nylon base strengthened with glass fibres and a strong, resistant, thick and transparent Plexiglas surface. This assures the best shockproof resistance, beyond resistance to direct sunlight, humidity and rain.



SPLENDOR

Lighting and signalling systems.



Code	Description	Power	€ / Pcs
SPL VIP	Flashing device (25W) 50H to be connected to LIFE electronic cards.	230V 50Hz	45,00
SPL24 VIP	Flashing device (25W) to be connected to LIFE "P series" electronic cards."	24V	45,00
SPLX VIP	Flashing device (25W) equipped with electronic flashing circuit.	230V 50Hz	48,00
SPL24X VIP	Flashing device (25W) equipped with electronic flashing circuit.	24V	48,00

SKANX	Matching antenna for flashlight SPL series and RG58 coaxial cable.		19,00
--------------	--	--	--------------



ASP	Supporting bracket for mounting of embossed flashlight.	(Pcs/Box 4)	24,00
------------	---	--------------------	--------------







SPL	Flashing device (25W) 50H to be connected to LIFE electronic cards.	230V 50Hz	33,00
SPL24	Flashing device (25W) to be connected to LIFE electronic cards."	24V	33,00



FULGOR

Signalling systems.

Code	Description	€ / Pcs
 FULGOR	Lamp complete with 230V a.c. 8W energy saving light bulb.	69,00
FUL6	Supporting post for FULGOR and SPLENDOR (not included). Height 600 mm.	20,00
 FUL10	Supporting post for FULGOR and SPLENDOR (not included). Height 1000 mm.	30,00
 FUL15	Supporting post for FULGOR and SPLENDOR (not included). Height 1500 mm.	40,00
 FULBA	Foundation plate for FUL post. Full of anchor clamps	(Pcs/Box 4) 48,00



COTTON T-SHIRT
SHORT SLEEVE
Sizes M, L, XL

€ 10,00

COTTON T-SHIRT
LONG SLEEVE
Sizes M, L, XL

€ 12,00



BASEBALL CAPS
One size only

€ 5,00



FLEECE TOP EDITION
Sizes M, L, XL

€ 35,00



PLASTIC BAGS
Available in 50 pcs lots

€ 39,00



CATALOGUE

€ 12,00

FOLDING BROCHURE
100 pcs

€ 34,00



WRITING PADS
Available in
50 pcs lots

€ 60,00



MULTIFUNCTION
WORKING JACKET
Taglie M, L, XL

€ 25,00



BALL POINT PENS
Available in
50 pcs lots

€ 39,00

Estore



BALL POINT PENS
Available
in 50 pcs lots

€ 470,00



STICKER SIGN FOR WINDOW
OR VEHICLE DISPLAY
Available in 10 pcs lots

€ 39,00



PACKING SELLOTAPE
Available in
36-roll packs
€ 99,00



PROSECCO DOC
by VIGNE MATTE
Available in
6 btl boxes

€ 48,00



NEON LIGHT SIGN FOR
SHOP
205x45x12

€ 350,00



NEON LIGHT SIGN FOR
SHOP
70x35x14

€ 169,00

GE2 R / RG2 R

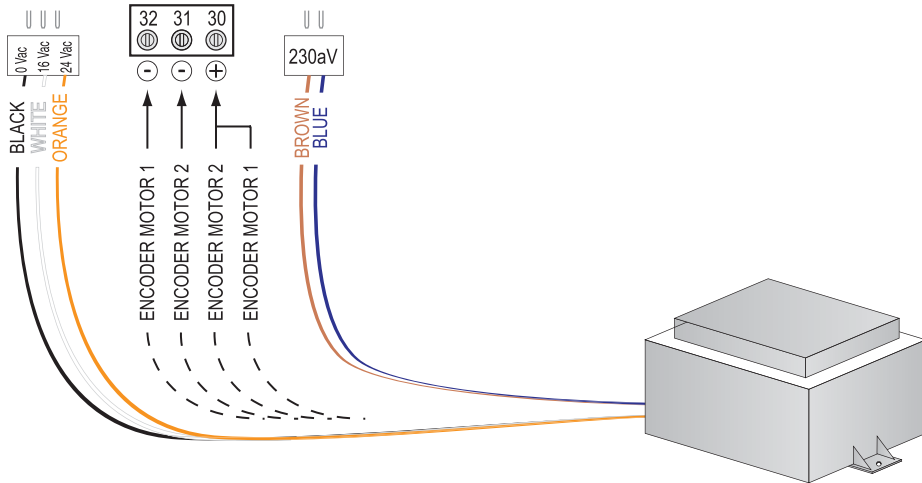
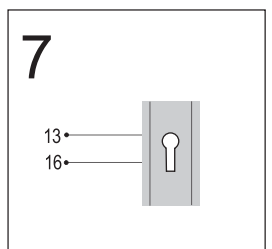
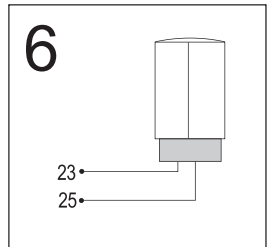
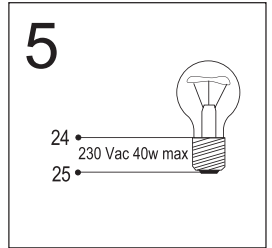
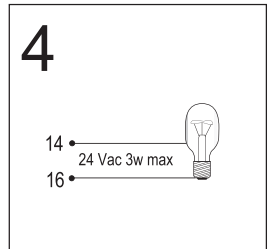
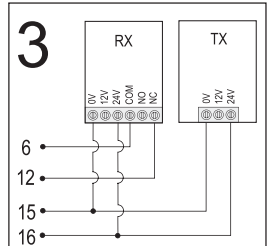
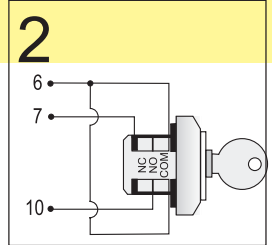
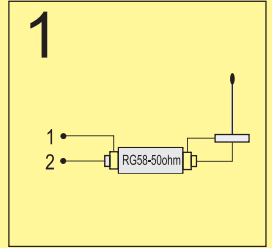
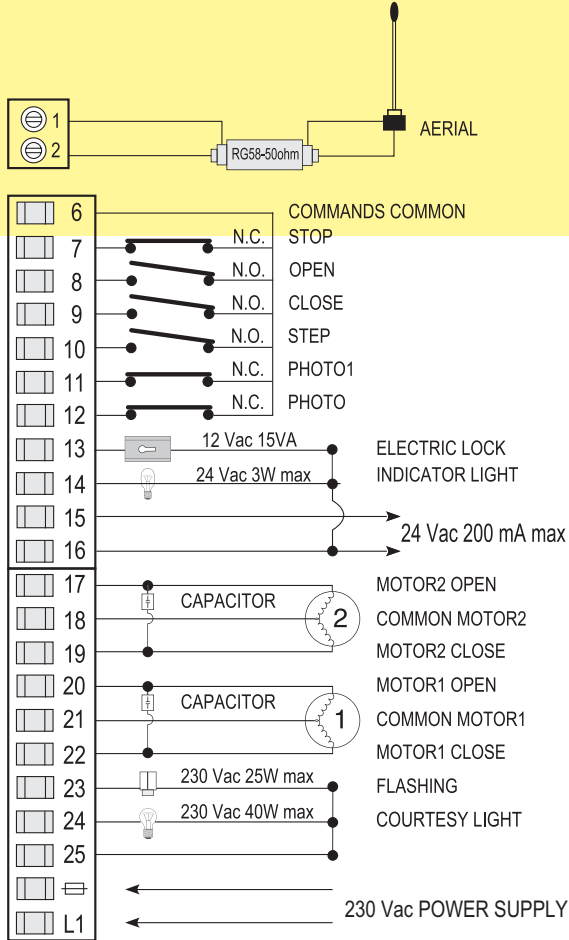
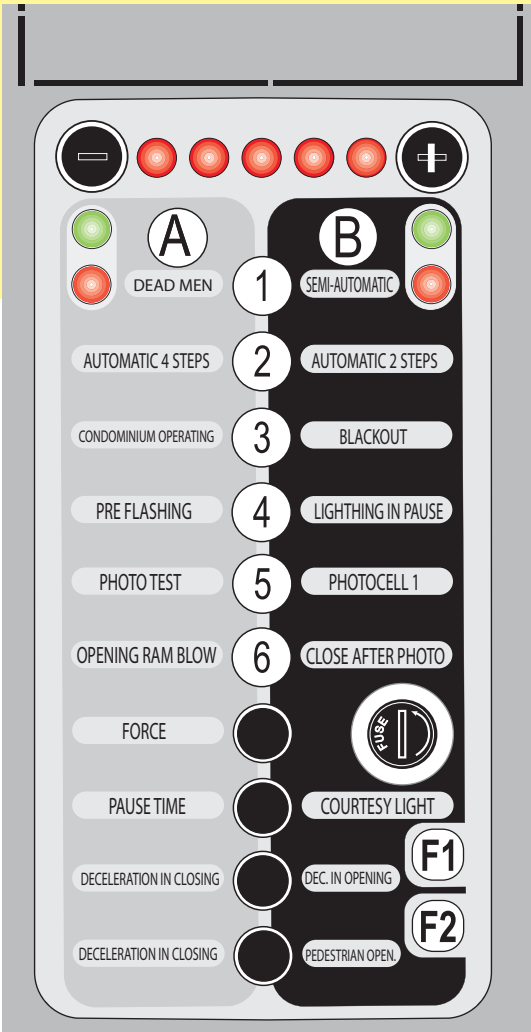

GE2 A / RG2 A

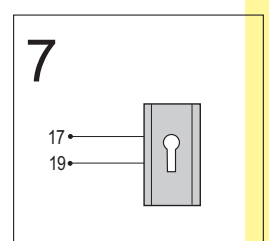
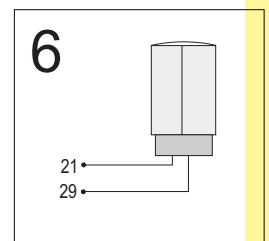
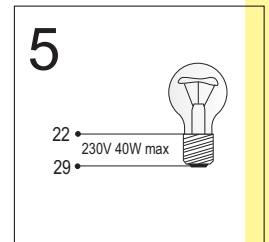
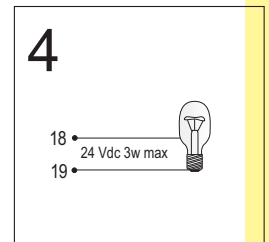
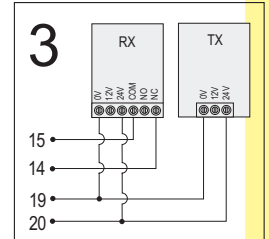
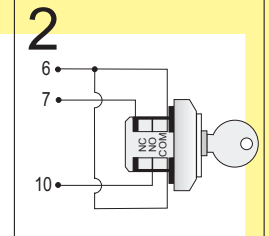
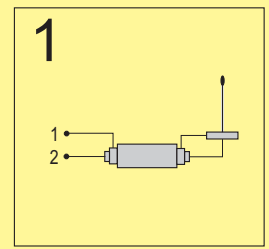
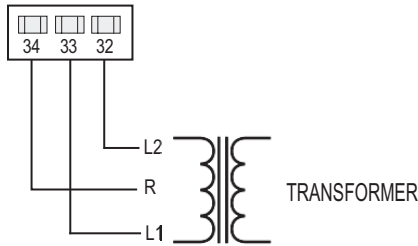
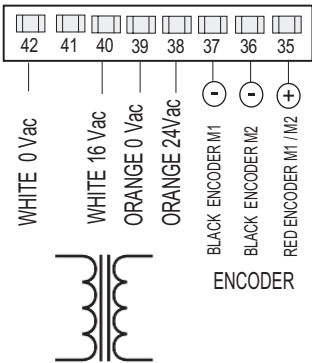
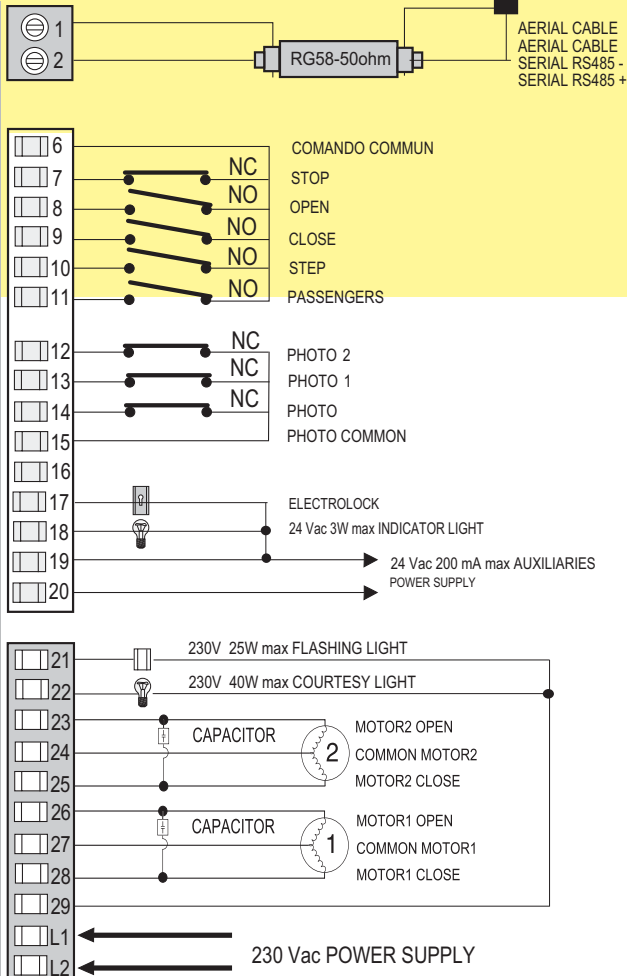
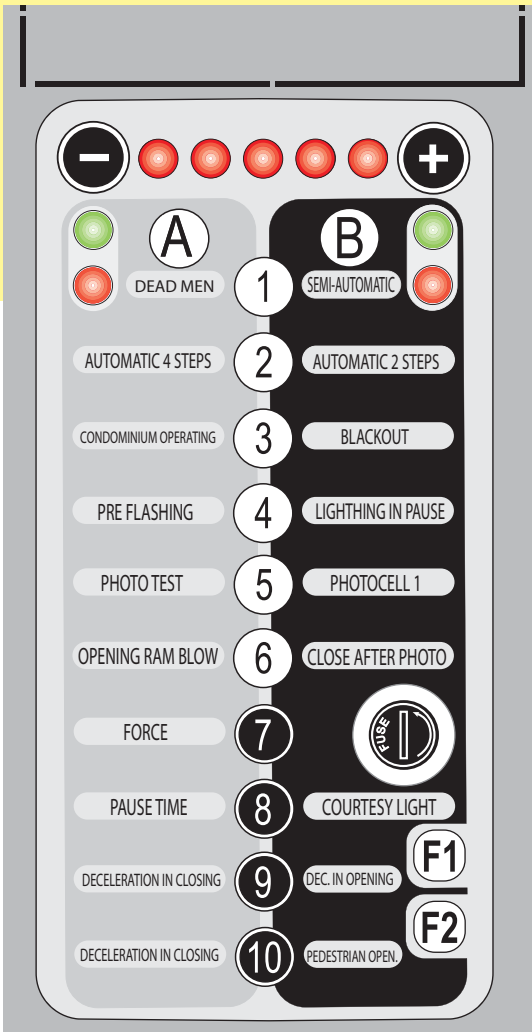

GE2 A 24 / RG2 A 24

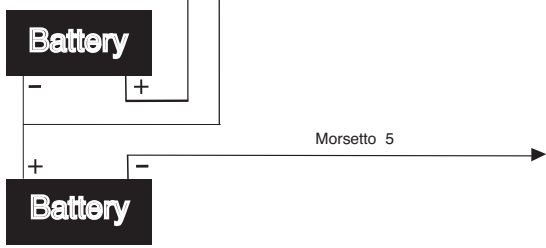
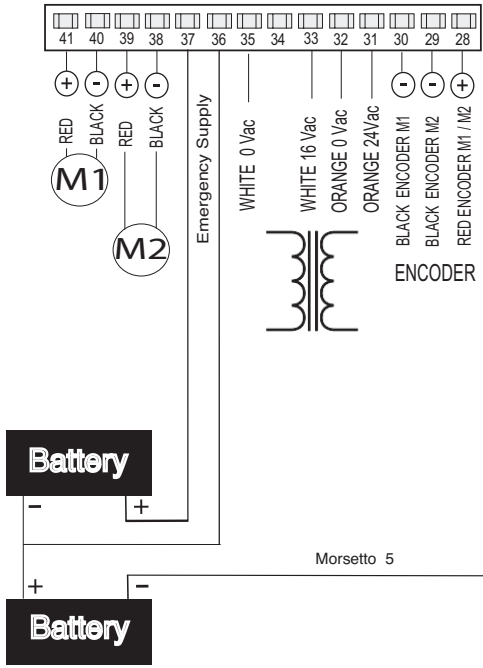
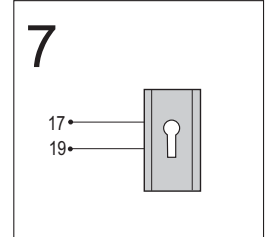
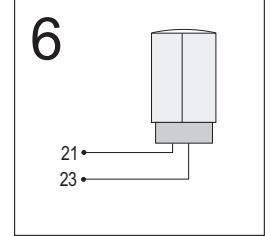
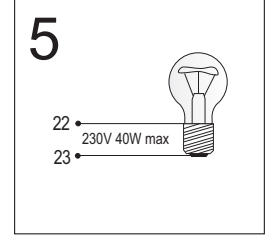
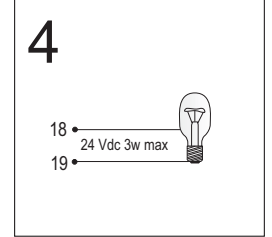
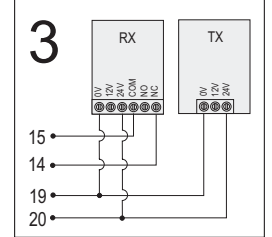
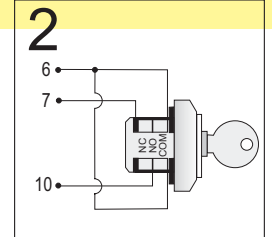
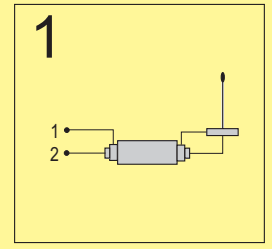
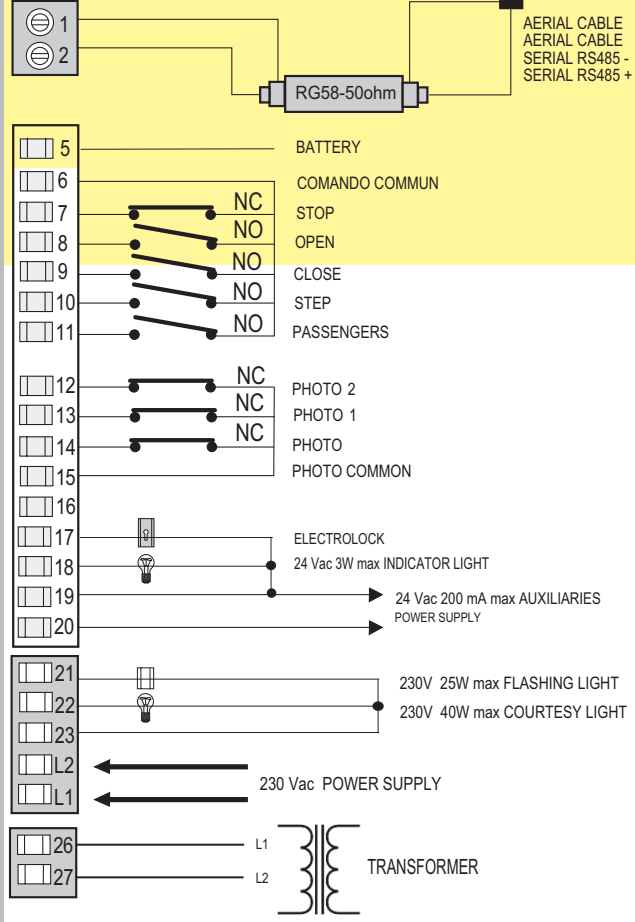
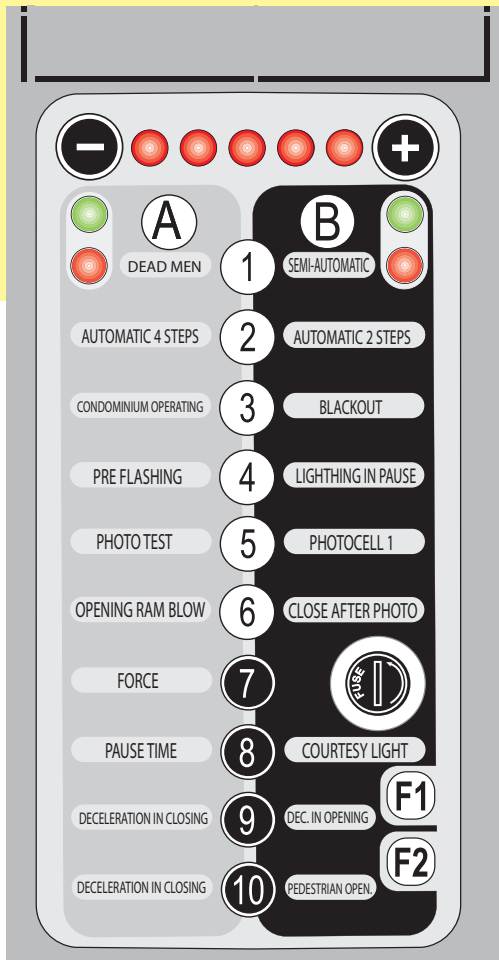

GE1 A 24 / RG1 A 24

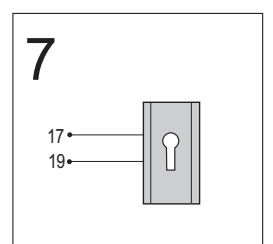
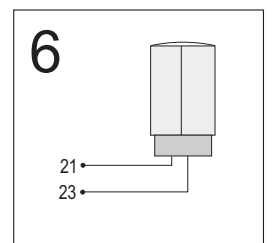
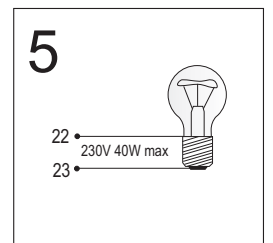
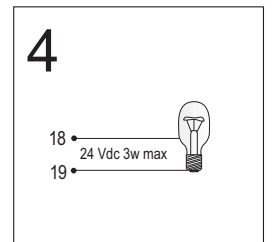
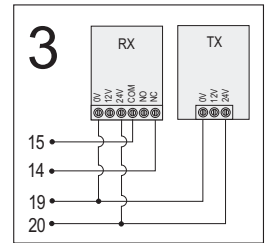
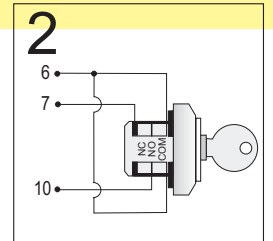
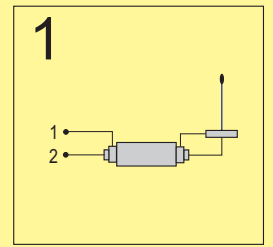
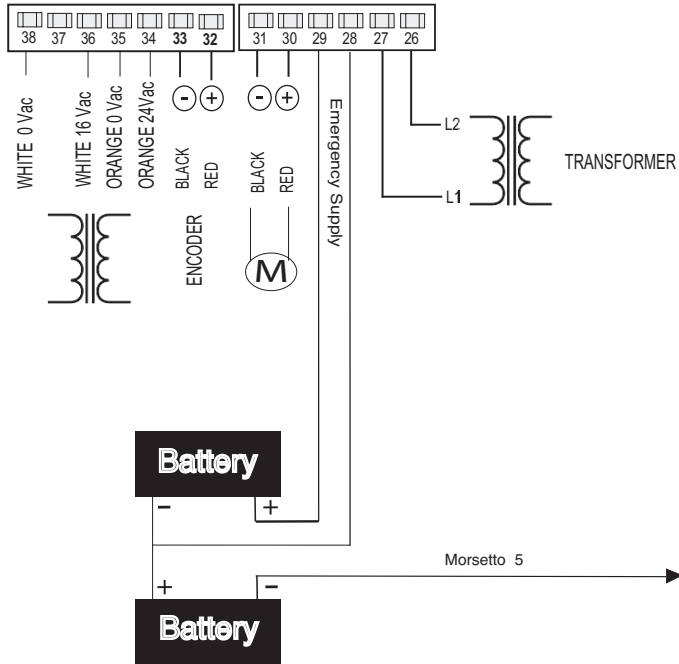
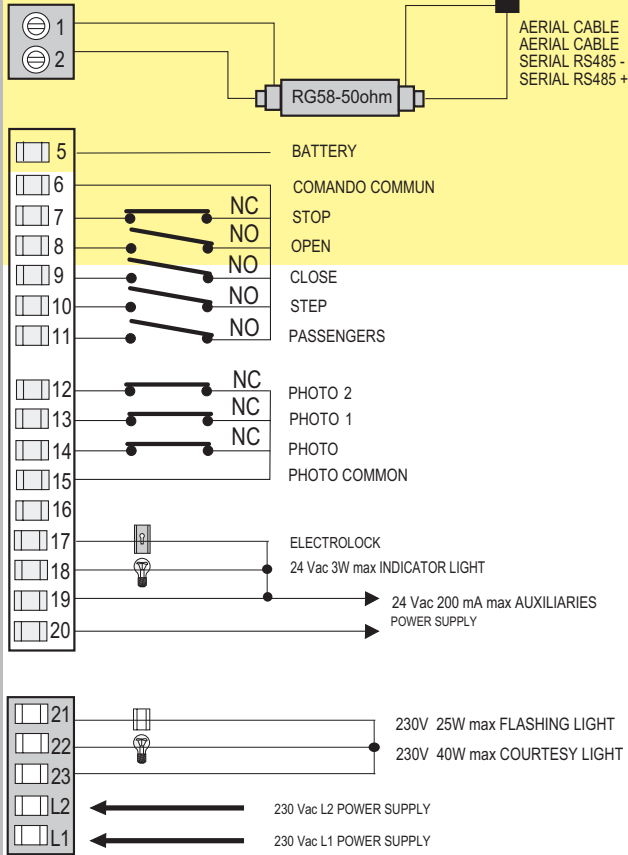
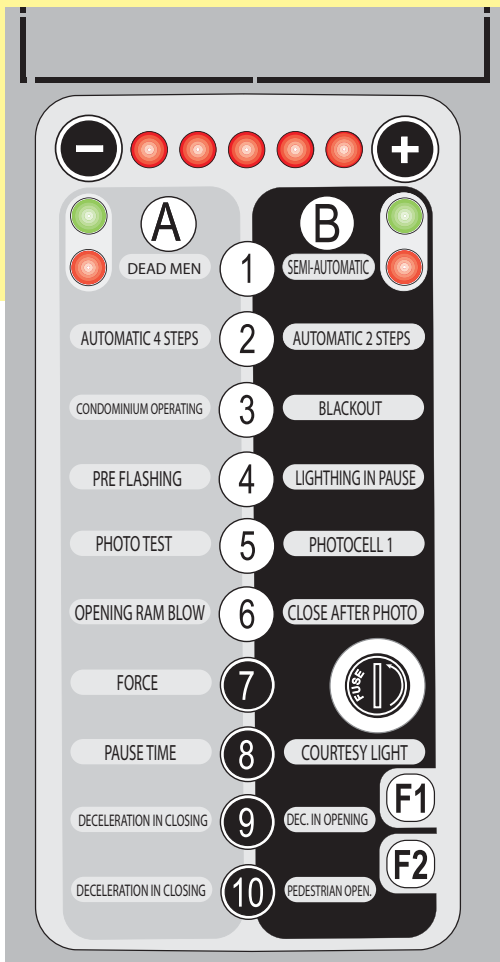

GE1 A / RG1 A

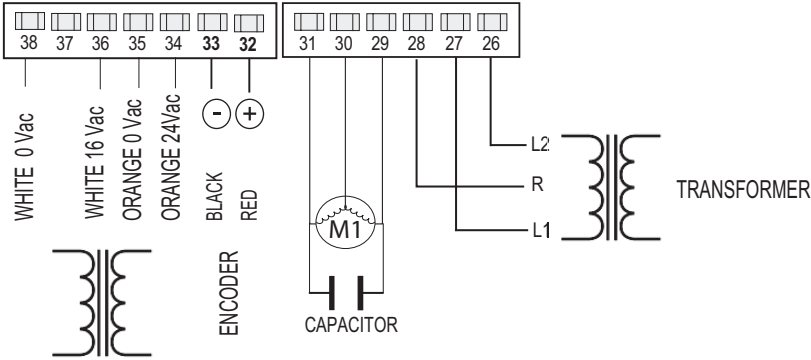
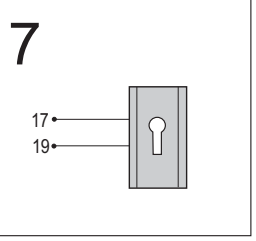
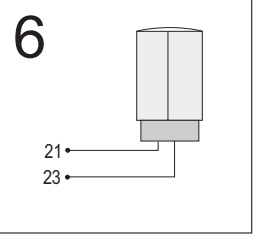
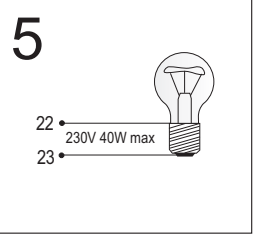
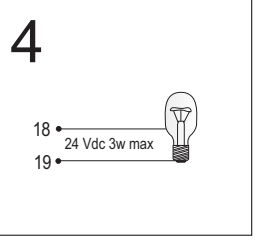
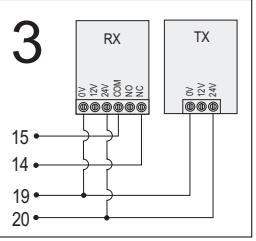
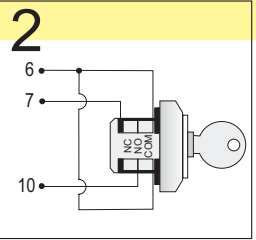
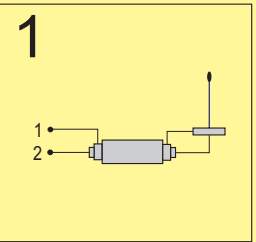
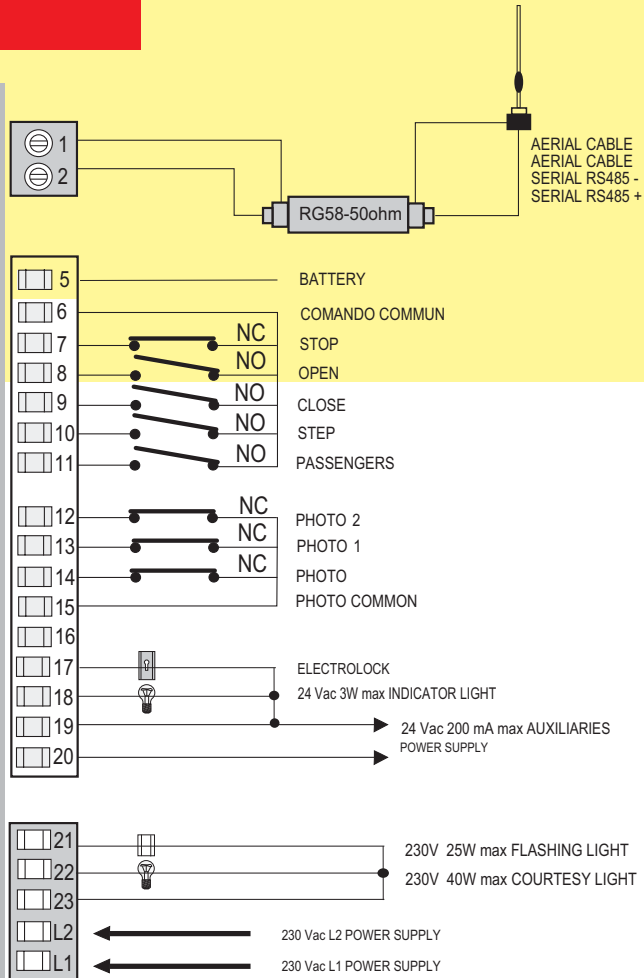
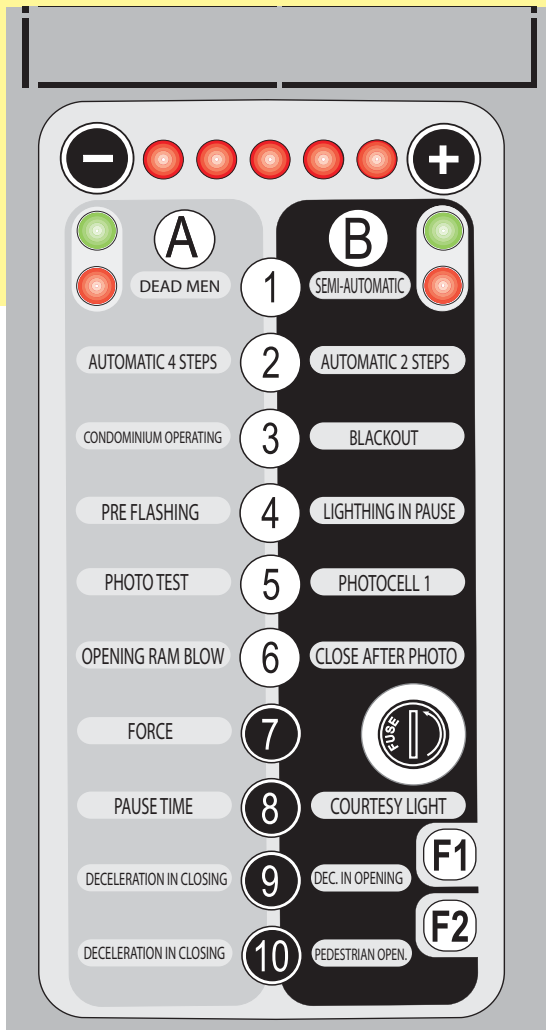

GEUNIR / RGUNIR

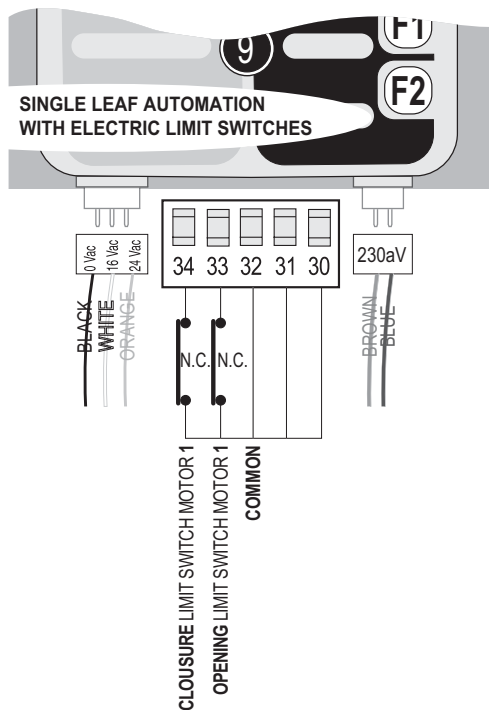
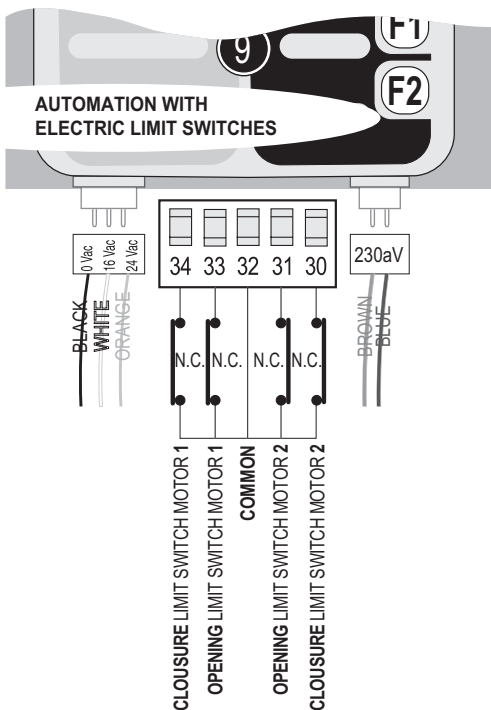
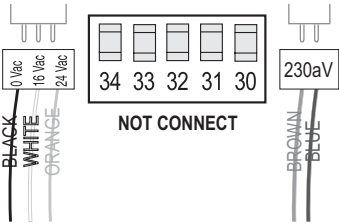
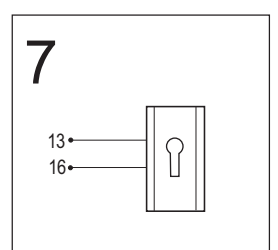
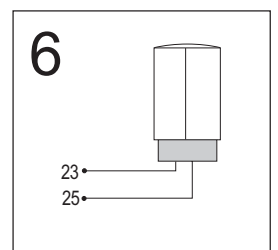
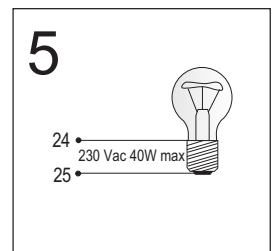
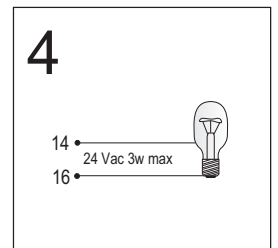
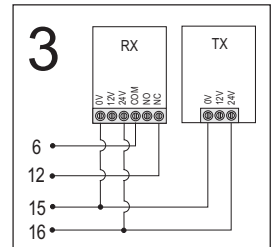
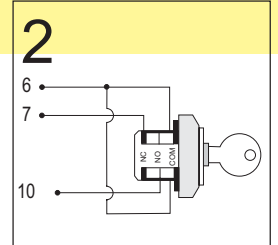
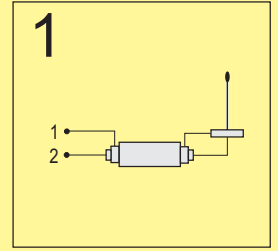
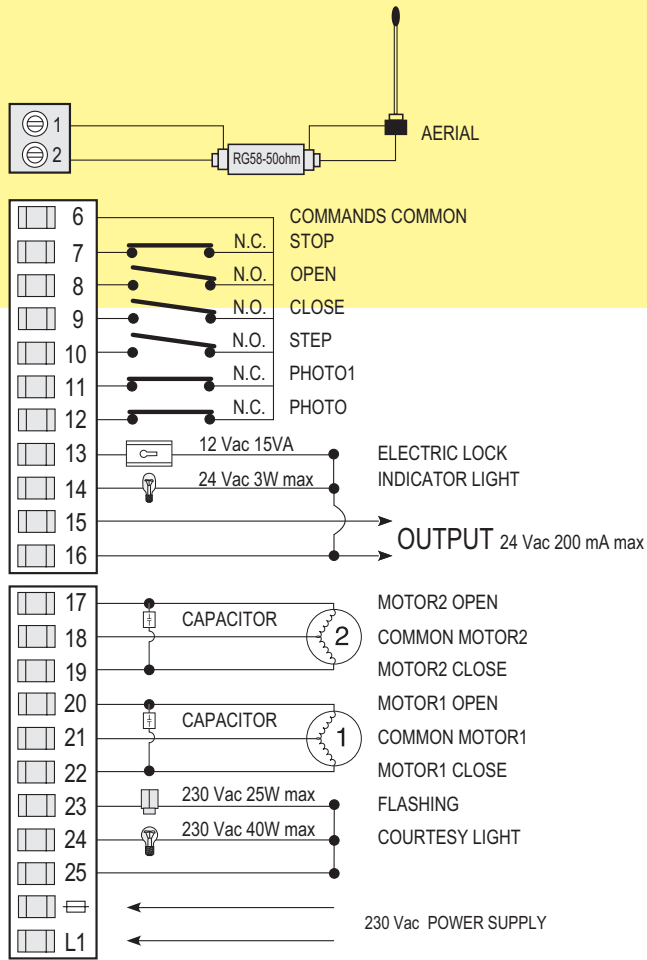
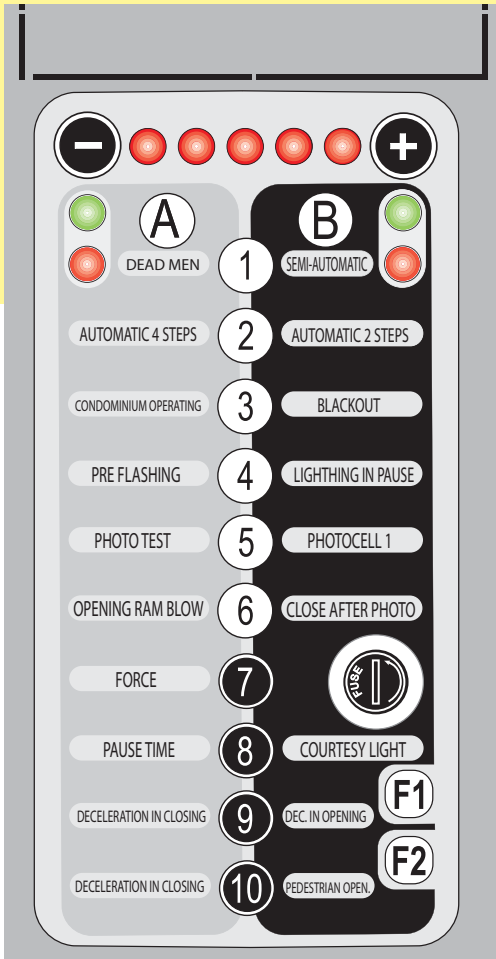

GEUNI 24 R DL / RGUNI24R DL

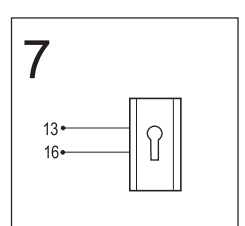
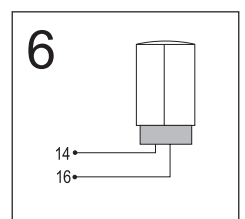
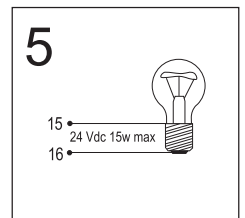
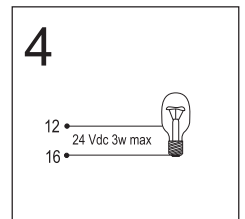
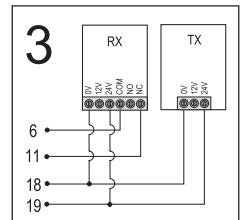
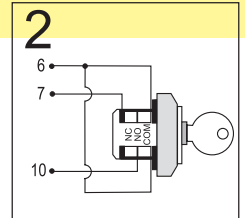
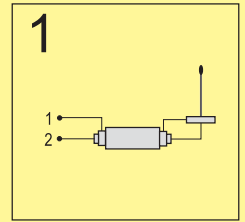
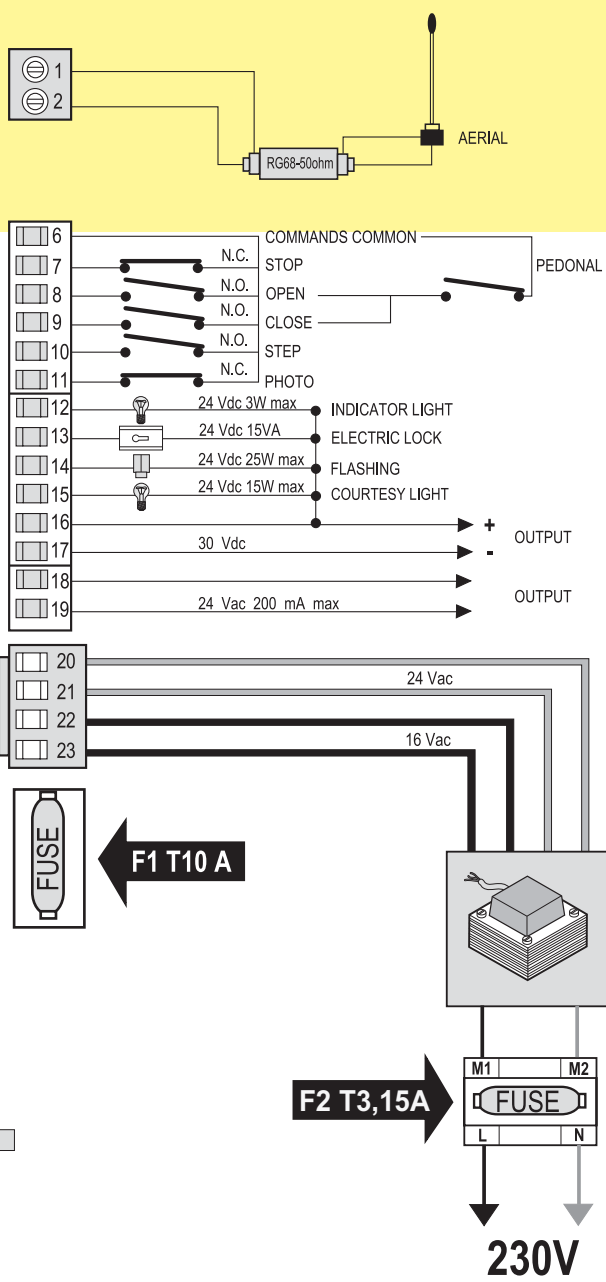
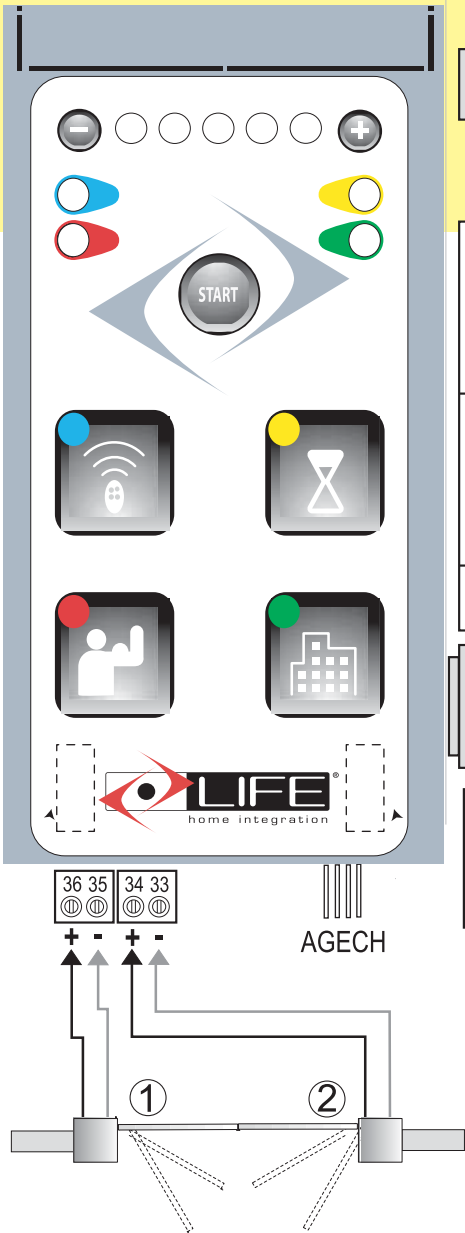

GEUNIR S DL / RGUNIR S DL

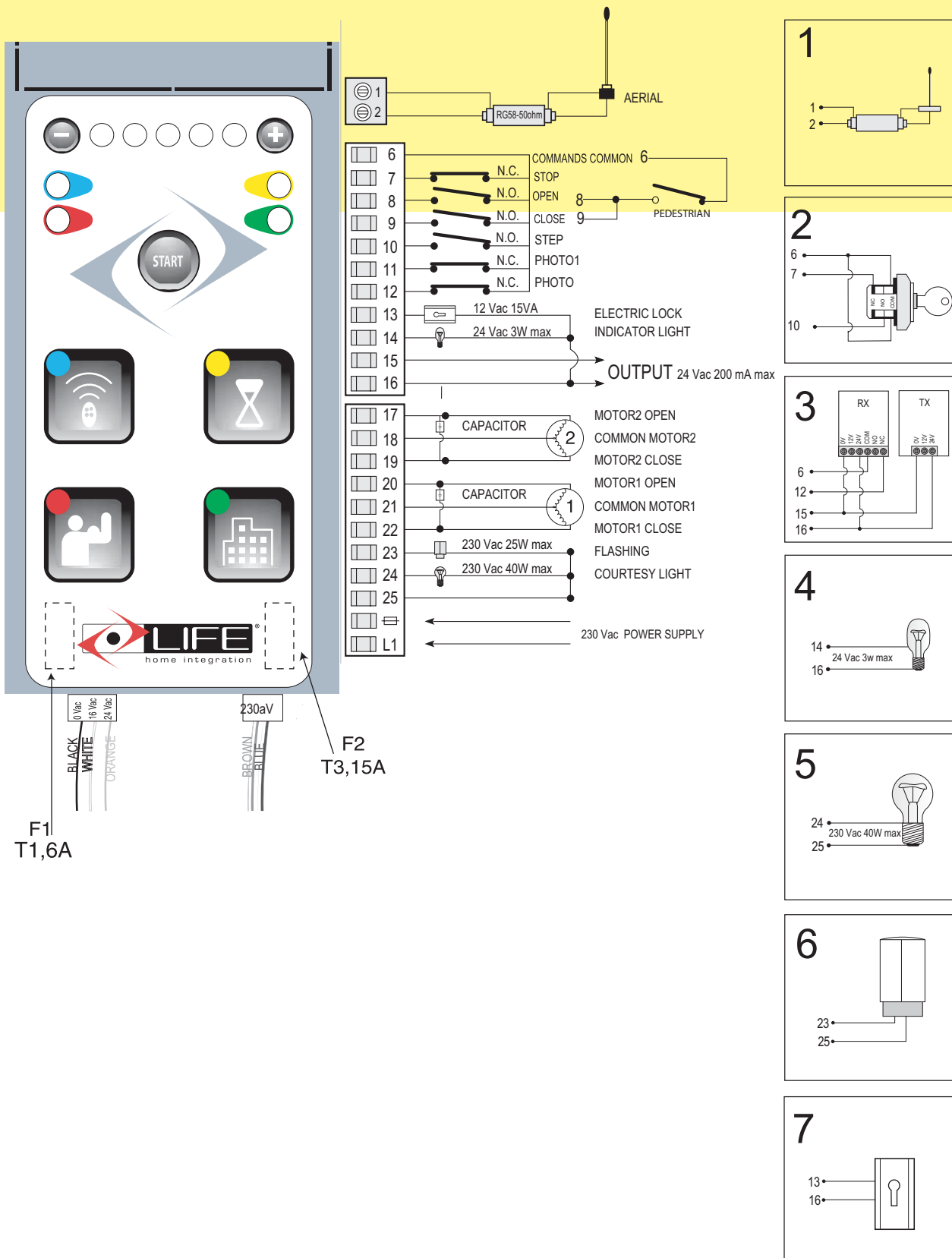

RG1 R DL / RG1 R UNI DL

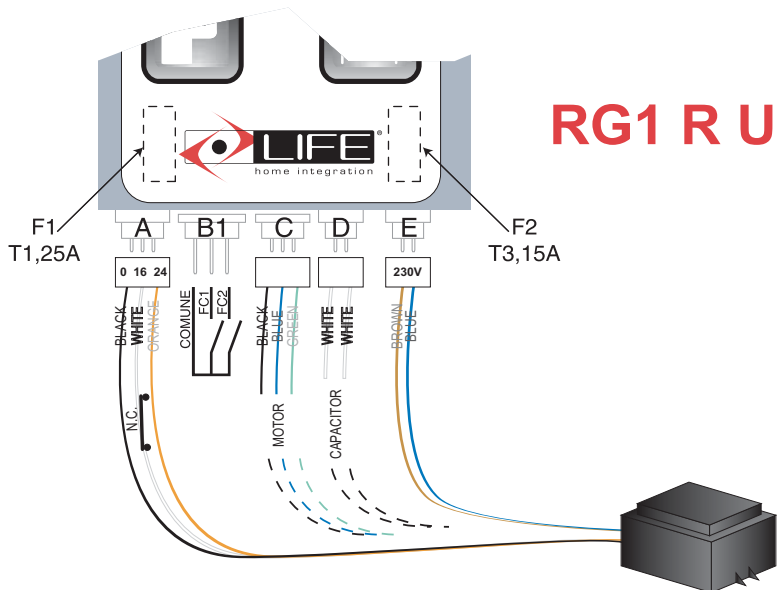
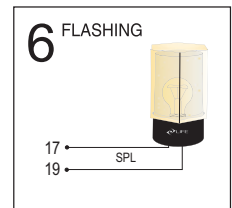
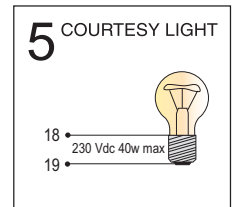
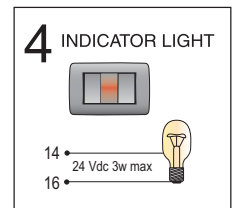
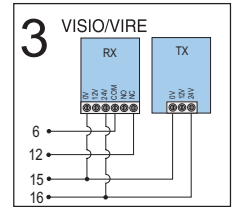
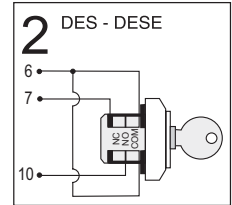
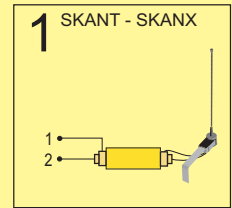
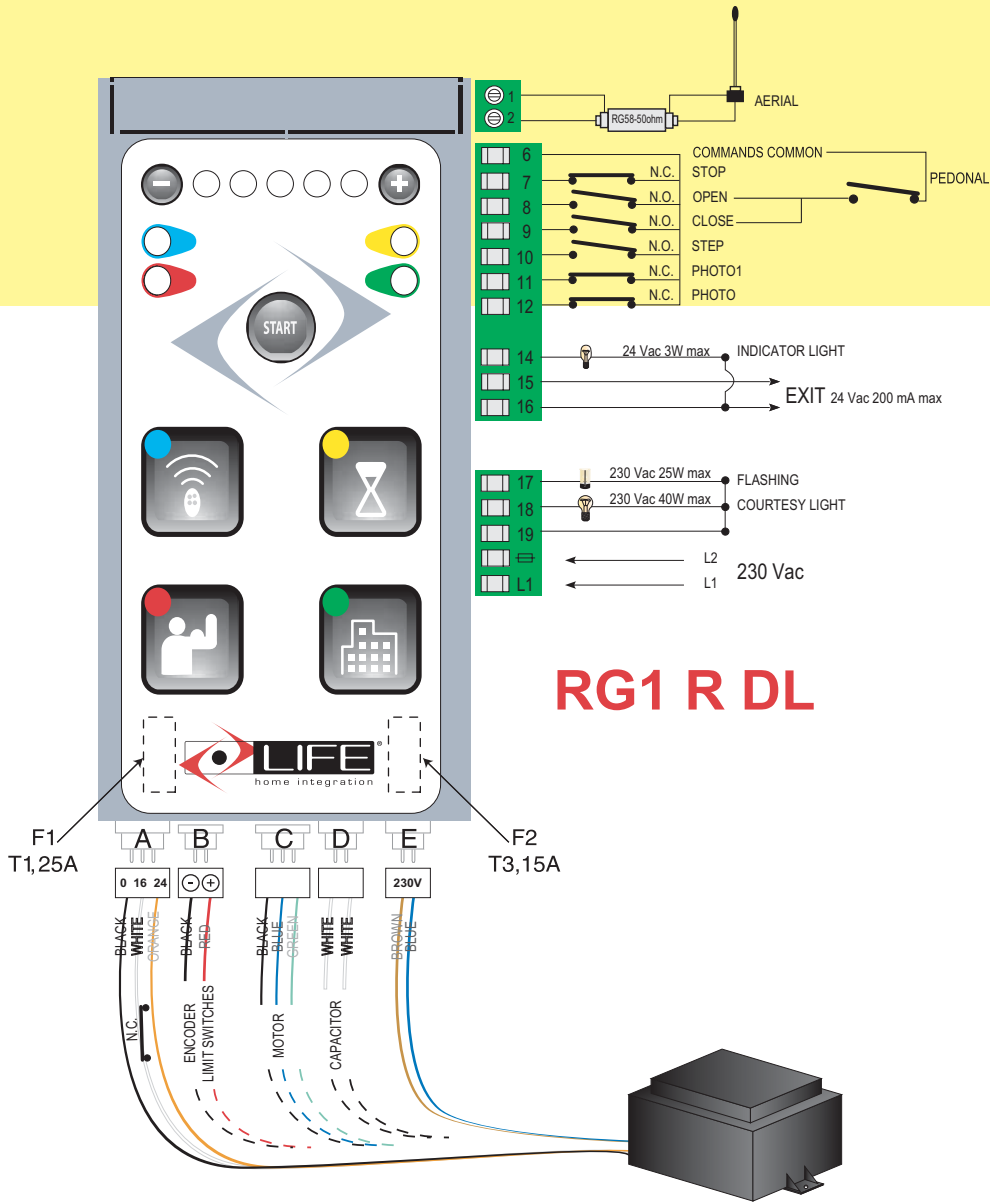

RG1 R 24 DL

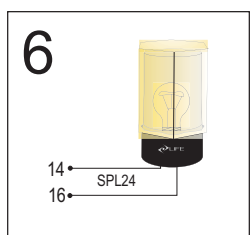
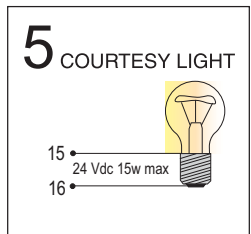
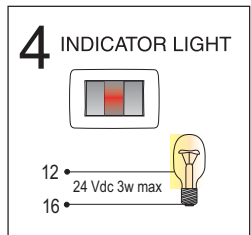
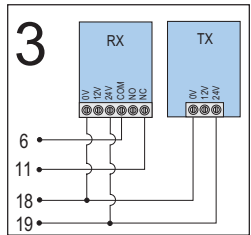
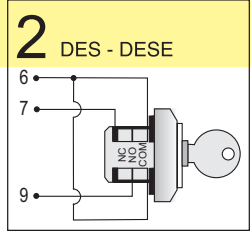
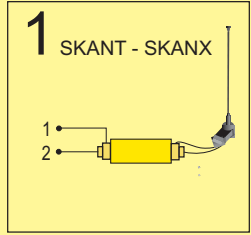
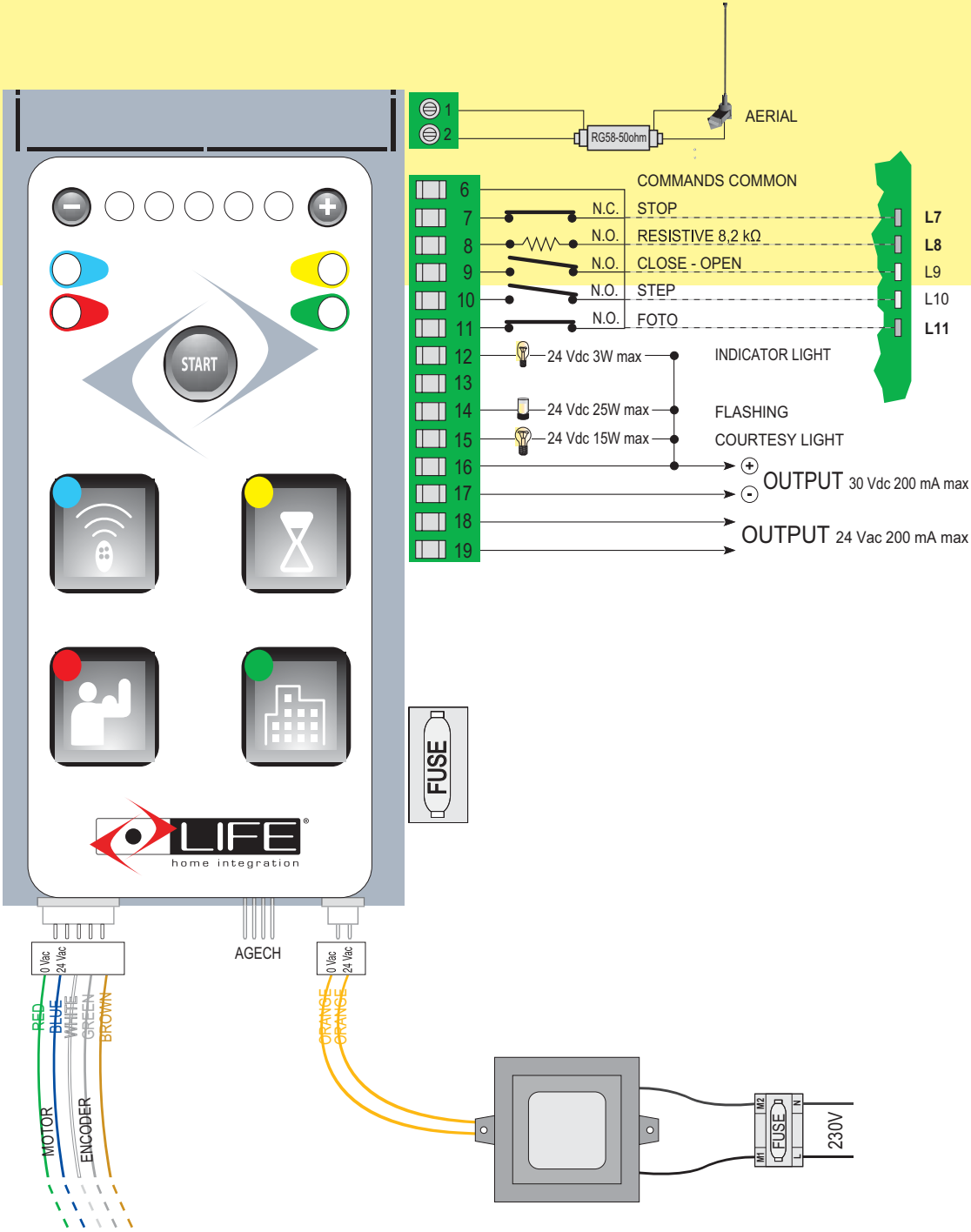

ORDER MODULE

Spett.

Date

Delivery date



Company

Adress

Via Pertini, 3/5
 31014 Colle Umberto (TV) - Italia
 T. +39 0438 388592
 F. +39 0438 388593
 www.homelife.it - info@homelife.it

Post code

Province

Nation

Tel.

Fax

Position	Code	Article description	Q/ty	Pret unitar	Total
1				€	€
2				€	€
3				€	€
4				€	€
5				€	€
6				€	€
7				€	€
8				€	€
9				€	€
10				€	€
11				€	€
12				€	€
13				€	€
14				€	€
15				€	€
16				€	€
17				€	€
18				€	€
19				€	€
20				€	€
21				€	€
22				€	€

Note

Order total

€

Shipment to means

Port

Payment

Petitioner

Signature

I CONSENT THE ACCORDING TO TREATMENT OF MY PERSONAL DATA OF ART. 675/96

GENERAL SALES CONDITIONS

All sales concluded by with Clients are governed by the General Conditions set out herein, which constitute an integrant part of the sales contracts that LIFE HOME INTEGRATION SRL and the Client will stipulate during the validity period of the same.

1. Orders

LIFE HOME INTEGRATION SRL reserves the right to refuse, either partially or entirely, orders transmitted by the Client, within 15 days of receipt. Failure to give notice of the refusal within said term constitutes the acceptance of the order. The Client may not cancel, either partially or entirely, orders made to LIFE HOME INTEGRATION SRL after 10 days from their transmission to LIFE HOME INTEGRATION SRL; in the event of order cancellation after said term, LIFE HOME INTEGRATION SRL will in any case be entitled to full payment for the order.

2. Catalogues and price lists

The information provided in catalogues and other illustrative material have an approximate value only and may be altered by LIFE HOME INTEGRATION SRL at any time. LIFE HOME INTEGRATION SRL has the unchallengeable right to vary the prices given in prices lists, which may not therefore be considered as binding towards LIFE HOME INTEGRATION SRL. Each new LIFE HOME INTEGRATION SRL price list cancels and replaces any previous ones. LIFE HOME INTEGRATION SRL price lists are intended as ex works, VAT excluded.

3. Delivery and terms of delivery

Deliveries will be performed ex works from LIFE HOME INTEGRATION SRL's premises in Colle Umberto (Treviso). Unless agreed otherwise, the delivery deadline will be 30 working days from express acceptance of the order, or, in the case of lacking acceptance, from the final term for refusal as indicated in art. 1 of these General Conditions. Delays in deliveries that do not exceed the limits of reasonable tolerance will not make the Client eligible to request partial or total termination of the contract or to claim compensation for damages. LIFE HOME INTEGRATION SRL fulfils its delivery obligations on delivery of the goods to the transporters. LIFE HOME INTEGRATION SRL will not be considered inadequate in its obligation to deliver in the event of fortuitous cases or of absolute unforeseen events, strikes, terrorist attacks, natural disasters or in any case of impossibility, beyond LIFE HOME INTEGRATION SRL's control, of receiving raw materials supply.

4. Dispatches

With the exception of agreements to the contrary, dispatches will take place by means of the courier indicated by LIFE HOME INTEGRATION SRL, which will charge the cost of said service to the Client in invoices. Delivery to the courier transfers all risks to the client.

5. Product collection

The Client will collect the goods as soon as they are made available. Should the Client delay in collecting the goods beyond the limits of reasonable tolerance, LIFE HOME INTEGRATION SRL will be eligible for a refund for the storage of the goods, unless other compensation is claimed. LIFE HOME INTEGRATION SRL will not accept responsibility for damage to uncollected goods or goods collected late during storage in its premises or warehouses or any public premises, where they are stored.

6. Guarantee and exemption from responsibility.

With the exception of the provisions given in article 8 of these General Conditions, LIFE HOME INTEGRATION SRL guarantees its own products against faults in the material used and/or manufacture faults on the condition that the products are or have been installed and used in an appropriate manner in compliance with the indications and instructions provided. The guarantee lasts for 30 months from the manufacture date marked on each product. Whilst products are under guarantee, the Client will have the right to the repair and/or replacement of faulty products, with the exclusion of compensation for any other impairment, damage or expense, of any kind, sustained by the Client. Replaced products remain property of LIFE HOME INTEGRATION SRL. Under no circumstances will LIFE HOME INTEGRATION SRL accept responsibility for problems deriving from incorrect installation of products and/or non-compliance with assembly or electrical connection instructions, namely non-compliance with safety regulations concerning electric products and/or other regulations in force at the time of installation. Under no circumstances will LIFE HOME INTEGRATION SRL accept responsibility for its electric and/or mechanical components or accessories connected without following the wiring diagrams and/or type of connection for which they were designed. Similarly, LIFE HOME INTEGRATION SRL will not accept responsibility in the case of use and application of the products for purposes incompatible with their nature, capacity and load limit. For material no longer under guarantee, when possible, LIFE HOME INTEGRATION SRL guarantees an assistance service for the repair of equipment, the expenses for which will be charged to the Client.

7. Exclusion from the right to opt out ex art. 1519

quinquies of Italian Civil Code With the exception of the provisions of the previous point, the Client is explicitly excluded the possibility to opt out against LIFE HOME INTEGRATION SRL, under art. 1519 V of the Italian Civil Code.

8. Apparent faults in goods supplied

Any claims for visible damage or faults to the packaging containing the products must be reported to LIFE HOME INTEGRATION SRL on reception, under penalty of forfeiture of the right. Any other apparent fault to the goods that is not visible from external inspection of the packaging, must be reported to LIFE HOME INTEGRATION SRL with a registered letter with return receipt, to be sent within 8 days of consignment of the products, under penalty of forfeiture of the right. If the goods are faulty and the Client has reported the fault promptly and within the guarantee period, the Client will be eligible for a replacement product subject to the return of the faulty product to LIFE HOME INTEGRATION SRL. The Client may not, however, claim for damage and/or compensation of any kind. LIFE HOME INTEGRATION SRL is exonerated from all other responsibilities.

9. Proprietorship

LIFE HOME INTEGRATION SRL reserves the proprietorship of the goods sold until full payment of the price is received. Cheques, promissory notes and credit transfers will only be considered as payments from the date of collection.

10. Conditions of payment

All payments must be made to LIFE HOME INTEGRATION SRL only and performed according to the terms and modalities indicated on invoices. The Client may not under any circumstances suspend and/or delay payment of the price to LIFE HOME INTEGRATION SRL beyond the terms established, even if prompt notification is given to LIFE HOME INTEGRATION SRL.

11. Faculty to opt out due to lacking full or part payments

In the event of delays in the payment even of just one of the instalments and deadlines established, LIFE HOME INTEGRATION SRL reserves the right to suspend – even without prior notice – the transfer/delivery of the goods ordered, and/or to opt out from any contracts in progress, even when different from those to which the lacking payment refers, without the Client being eligible to compensation or damages of any kind. Lacking payment within the terms stipulated will also make LIFE HOME INTEGRATION SRL eligible to subordinate further deliveries to the full payment of the expired price plus the relevant interest, and due to the Client's forfeiture to cancel the benefit of the terms on subsequent payments, in other words LIFE HOME INTEGRATION SRL has the faculty to demand the immediate provision of adequate guarantees.

12. Other faculties to opt out

LIFE HOME INTEGRATION SRL is guaranteed the right to opt out, without entitling the Client to any compensation whatsoever, in the event of changes in the person or company set up of the Client, and in cases of legal proceedings, bankruptcy proceedings, the issue of payment injunctions, suspensions, deferrals or delays in the fulfilment of obligations towards third party creditors.

13. Prohibition of compensation

With the exception of written agreements to the contrary, compensation between the credits and debts of which LIFE HOME INTEGRATION SRL and the Client are mutual owners will not be allowed for any purpose, reason or cause.

14. Brands and distinguishing marks

The Client undertakes not to remove, conceal or alter marks made on the products by LIFE HOME INTEGRATION SRL. The Client is forbidden to use the brand(s) owned by LIFE HOME INTEGRATION SRL as, or in its own trade name, unless prior authorisation to do so is obtained from LIFE HOME INTEGRATION SRL, which may establish the means, limits and duration of use of the brand(s).

15. Validity and effectiveness of these conditions

These conditions are applicable to all sales contracts stipulated between LIFE HOME INTEGRATION SRL and the Client for 5 years after signature by the Parties.

16. Jurisdiction and competent forum

Any controversies that may arise in connection with the fulfilment, interpretation and validity of these General Conditions of Sale will be dealt with under Italian Law. The sole competent forum is the tribunal of Treviso.

17. Applicable law

These General Conditions will be subject to Italian law. The single contracts governing the commerce of the products will also be subject to Italian law, with the exclusion expressed by the Vienna Convention of the 11th April 1980.

18. Translations and original version

Should the Parties sign a copy of these General Conditions translated into a language other than Italian, in the event of controversy concerning the meaning or extent of any clause, the original version is the text written in Italian.