



O&C

GENERAL CATALOGUE 2012

PAST PRESENT FUTURE

OPENERS & CLOSERS was founded in Barcelona in 1989, with the aim of manufacturing superior door locks and providing an efficient customer service.

After more than 20 years of experience, O&C is one of the leading European manufacturers of electric strikes and electromagnetic locks, exporting approximately 90% of its production in over 40 different countries around the world.

Such achievement is the result of the company's policy of constantly improving product quality while maintaining an affordable price, in combination with the staff engagement to educate, update and advise clients on a regular basis.

O&C currently owns over 30 patents for technical and production innovations, entirely designed and manufactured in Spain. Our products have been tested by APPLUS+ Norcontrol and LGAI Technological Center.

Our commitment to the environment is witnessed by the employ of quality recyclable materials, ensuring lower energy consumption and longer product life. As a matter of fact, all our products are guaranteed for 3 years.

OPENERS & CLOSERS: INNOVATION, QUALITY & SERVICE.



ELECTRIC STRIKES

vocabulary

Electric strike

Electric strikes (also called electric latch release or electric door openers) replace a standard strike mounted on the door frame and receive the latch and latch bolt.

Faceplate

Faceplates, in different shapes and finishes, allow the strike to be perfectly installed into any kind of frame.

* Personalized faceplates are available upon request.

Hold-open

This function allows unlocking with a single electric impulse and holds the strike unlocked until the door is opened.

Monitoring

This function will signalize the status of the door to your access control or interlocking system.

Mechanical unlocking

Activating this lever will keep the strike permanently opened until manually switched back.

Keeper

Keepers (fixed or adjustable, deep or shallow) allow the strike to work perfectly with any kind of latch.

* Personalized keepers are available upon request.

Electronic protection

A transil suppressor within the terminal block protects your access control system from current peaks.

Side-Load

It's the pressure exerted on the keeper by an external force (door weight, wind, bad installation, etc).

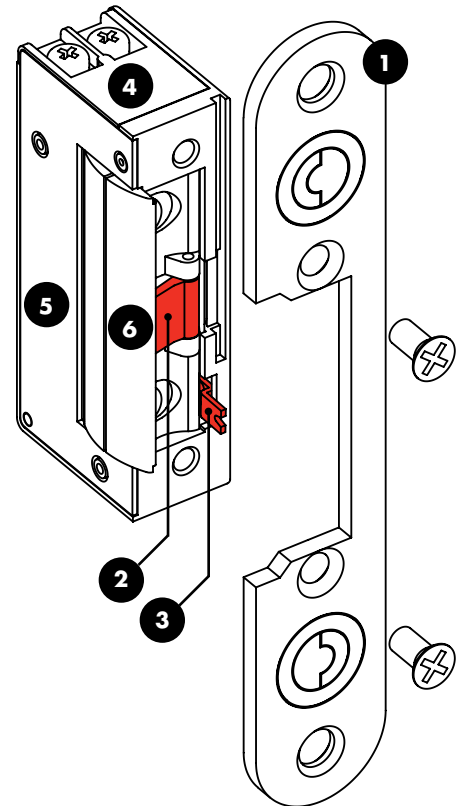

- 1 faceplate
- 2 hold-open pin
- 3 mechanical unlocking
- 4 Terminal block
- 5 cover
- 6 keeper

Reference Example

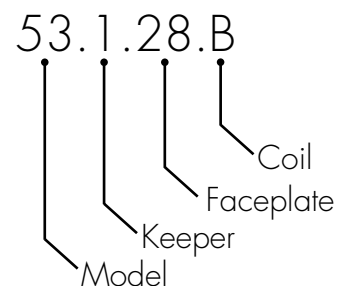

FUNCTIONS

Fail-secure

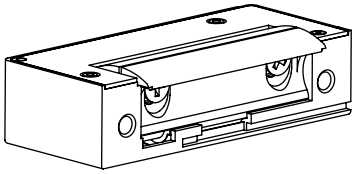

The electric strike is unlocked when energized.

Fail-secure with mechanical unlocking

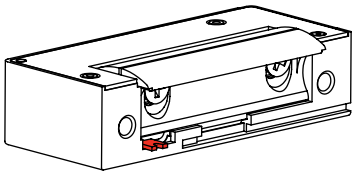

The electric strike is unlocked when energized.

It features a mechanical lever for manual release.

Fail-secure with monitoring

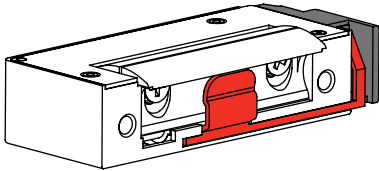

The electric strike is unlocked when energized.

It features a microswitch that detects the status of the door. (opened/closed)

Fail-secure with double monitoring

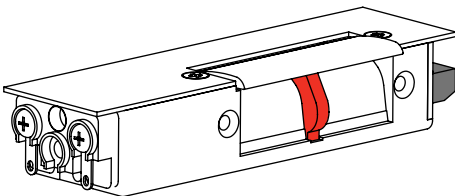

The electric strike is unlocked when energized.

It features 2 microswitches that detect the status of both the door (opened/closed) and the keeper (locked/unlocked).

Hold-open

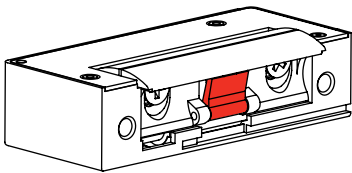

The pin on the keeper allows unlocking the strike through a single electric impulse.

The strike will stay unlocked until the actual opening of the door.

Hold-open with mechanical unlocking

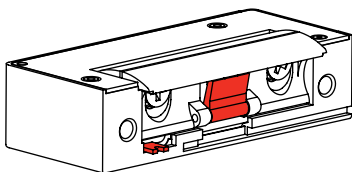

The pin on the keeper allows unlocking the strike through a single electric impulse.

The strike will stay unlocked until the actual opening of the door.

It features a mechanical lever for manual release.

Fail-safe

The electric strike is locked when energized.

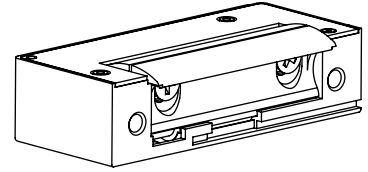

Fail-safe with monitoring

The electric strike is locked when energized.

It features a microswitch that detects the status of the door.
(opened/closed)

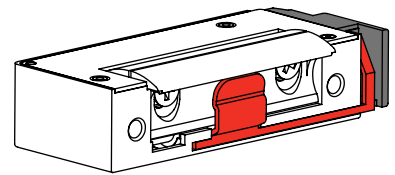

Fail-safe with double monitoring

The electric strike is locked when energized.

It features 2 microswitches that detect the status of both the
door (opened/closed) and the keeper (locked/unlocked).

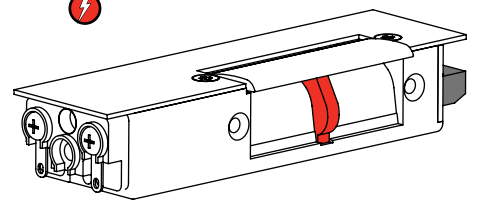

Internal Hold-open

An internal device allows unlocking the electric strike through a
single electric impulse.

The strike will stay unlocked until the actual opening of the door.

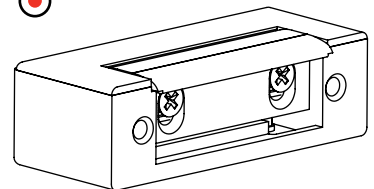

Internal Hold-open with mechanical unlocking

An internal device allows unlocking the electric strike through a
single electric impulse.

The strike will stay unlocked until the actual opening of the door.

It features a mechanical lever for manual release.

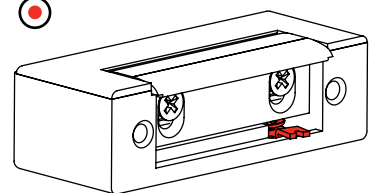

 fail-safe model

 internal hold-open model

ELECTRIC STRIKES

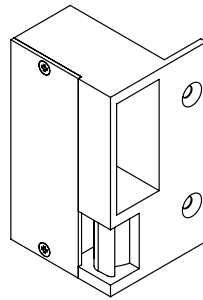
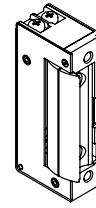
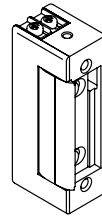
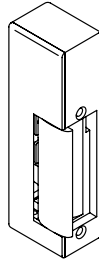

	VOLTAGE							BASIC Series 1 & 2		SYMMETRIC Series 3	MINI Series 5	RIM Series 1 & 2 RIM			
	Keeper	12 Vdc	24 Vdc	5-12 V ac/dc	6-12 V ac/dc	8-14 V ac/dc	9-14 V ac/dc	9-16 V ac/dc	References DIN right add faceplate	References DIN left add faceplate	References add faceplate	References add faceplate	References DIN right 9B for 90mm 12A for 120mm	References DIN left 9A for 90mm 12B for 120mm	
Fail-secure	Fixed			•			•	10.0.00.B	20.0.00.B				10.0.9B.B	20.0.9A.B	
		•						10.0.00.J	20.0.00.J						
		•						10.0.00.E	20.0.00.E						
	Adjustable	•							10.1.00.B	20.1.00.B	30.1.00.B				
		•							10.1.00.J	20.1.00.J	30.1.00.J				
		•						•	10.1.00.E	20.1.00.E	30.1.00.E	50.1.00.E			
				•				10.1.00.F	20.1.00.F	30.1.00.F			50.1.00.F		
					•								50.1.00.B		
						•							50.1.00.J		
Fail-secure with mechanical unlocking	Fixed			•			•	11.0.00.B	21.0.00.B						
		•						11.0.00.J	21.0.00.J						
		•						11.0.00.E	21.0.00.E						
	Adjustable	•							11.1.00.B	21.1.00.B	31.1.00.B				
		•							11.1.00.J	21.1.00.J	31.1.00.J				
		•							11.1.00.E	21.1.00.E	31.1.00.E	51.1.00.E			
				•				11.1.00.F	21.1.00.F	31.1.00.F			51.1.00.F		
					•								51.1.00.B		
						•							51.1.00.J		
Fail-secure with monitoring	Fixed	•													
		•													
	Adjustable	•												56.1.00.E	
		•												56.1.00.F	
													56.1.00.B		
													56.1.00.J		
Fail-secure with double monitoring	Fixed	•													
		•													
Hold-open	Fixed			•			•	12.0.00.B	22.0.00.B						
								12.0.00.J	22.0.00.J						
	Adjustable	•							12.1.00.B	22.1.00.B	32.1.00.B				
		•							12.1.00.J	22.1.00.J	32.1.00.J				
										32.1.00.E			52.1.00.B		
													52.1.00.J		
Hold-open with mechanical unlocking	Fixed			•			•	13.0.00.B	23.0.00.B						
								13.0.00.J	23.0.00.J						
	Adjustable	•							13.1.00.B	23.1.00.B	33.1.00.B				
		•							13.1.00.J	23.1.00.J	33.1.00.J				
										33.1.00.E			53.1.00.B		
													53.1.00.J		
Internal Hold-open	Fixed			•			•	12A.0.00.B	22A.0.00.B				12A.0.9B.B	12A.0.9A.B	
								12A.0.00.J	22A.0.00.J						
Adjustable	•							12A.1.00.B	22A.1.00.B	32A.1.00.B					
	•							12A.1.00.J	22A.1.00.J	32A.1.00.J					
Internal Hold-open with mechanical unlocking	Fixed			•			•	13A.0.00.B	23A.0.00.B						
								13A.0.00.J	23A.0.00.J						
	Adjustable	•							13A.1.00.B	23A.1.00.B	33A.1.00.B				
		•							13A.1.00.J	23A.1.00.J	33A.1.00.J				
										33A.1.00.E			14.0.9B.M	24.0.9A.M	
Fail-safe	Fixed	•													
		•													
Adjustable	•									34.1.00.E			54.1.00.E		
	•									34.1.00.F			54.1.00.F		
Fail-safe with monitoring	Fixed	•													
		•													
Adjustable	•													58.1.00.E	
	•													58.1.00.F	
Fail-safe with double monitoring	Fixed	•													
		•													

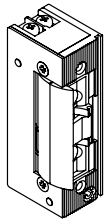

HIGH SECURITY

Series 25
References
add faceplate

250.1.00.J
250.1.00.E
250.1.00.F

250.1.00.B

256.1.00.E
256.1.00.F

256.1.00.B
256.1.00.J

252.1.00.B
252.1.00.J

4R2A.4.00.L

254.1.00.E
254.1.00.F

258.1.00.E
258.1.00.F

49.4.00.P
49.4.00.N

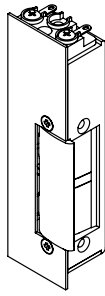

SECURITY
Series 4R & 4L

References
DIN right
add faceplate

References
DIN left
add faceplate

4R0.4.00.L

4R0.4.00.M

4R0.4.00.N

4R6.4.00.M

4R6.4.00.N

4R6.4.00.L

47.4.00.P

47.4.00.N

4I2A.4.00.L

4R4.4.00.M
4R4.4.00.N

4R8.4.00.M
4R8.4.00.N

49.4.00.P
49.4.00.N

IP 54

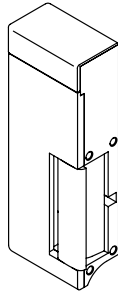

WATERPROOF
Series 7R & 7L

References
DIN right
add faceplate

References
DIN left
add faceplate

7R0.4.00.L

7R0.4.00.M

7R0.4.00.N

7R6.4.00.M

7R6.4.00.N

7R6.4.00.L

7R2A.4.00.L

7R4.4.00.M
7R4.4.00.N

7R8.4.00.M
7R8.4.00.N

7R8.4.00.N

RF 120

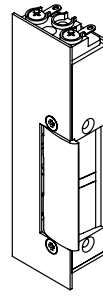

FIRE
Series 24R & 24L

References
DIN right
add faceplate

References
DIN left
add faceplate

24R0.4.00.L

24R0.4.00.M

24R0.4.00.N

24R6.4.00.M

24R6.4.00.N

24R6.4.00.L

47.4.00.P

47.4.00.N

24R4.4.00.P

24R4.4.00.N

24R8.4.00.P
24R8.4.00.N

49.4.00.P
49.4.00.N



EMERGENCY
Series 4

References
add box

40.6.00.L

40.6.00.M

40.6.00.N

46.6.00.M

46.6.00.N

46.6.00.L

47.6.00.P

47.6.00.N

42A.6.00.L

44.6.00.M
44.6.00.N

48.6.00.M
48.6.00.N

49.6.00.P
49.6.00.N

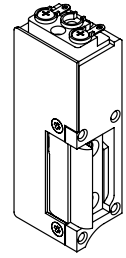

ARMOURED
Series 9R & 9L

References
DIN right
add faceplate

References
DIN left
add faceplate

9R0.1.00.M

9R0.1.00.N

9R0.1.00.M

9R0.1.00.N

9R0.1.00.L

9L0.1.00.M

9L0.1.00.N

9L0.1.00.L

9R2A.1.00.L

9L2A.1.00.L

9R2A.1.00.L

9L2A.1.00.L

9R3A.1.00.L

9L3A.1.00.L

9R4.1.00.M
9R4.1.00.N

9L4.1.00.M
9L4.1.00.N



BASIC

Series 1 & 2

Basic electric strikes are ideal for simple ironmongery installations, such as **home door phones**. They are available with fixed or adjustable keeper, for either DIN right or left doors.

Featuring a wide variety of functions and voltages, these strikes quickly unlock standard doors through low power consumption.

Technical features

- Max. side-load on AC: 160 N
Max. side-load on DC: 10 N
- Break-in resistance: 3.000 N
- Operating temperature range: -15 °C /+40 °C
- Housing: Zamak
Keeper: Zamak
- Guaranteed 3 years
- Complies with 2004/108/CE (EN 55014)
- Corrosion resistant according to UNI ISO 9227

Coil features

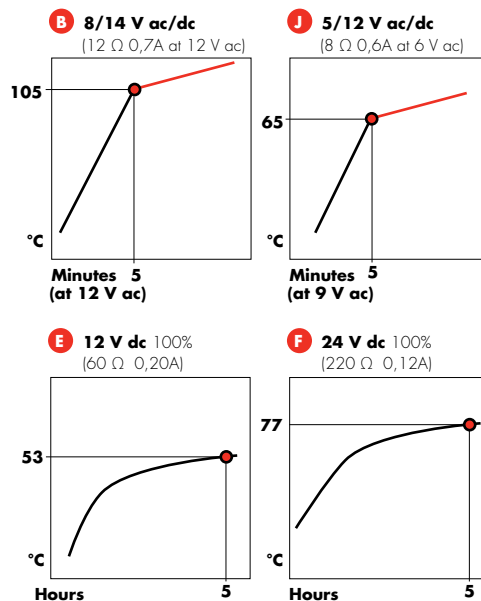

Personalized coils upon request

References and features

	Fixed keeper	Adjustable keeper	Side-load	Voltage	References DIN right add faceplate	References DIN left add faceplate
	•		•	8-14 V ac/dc	10.0.00.B	20.0.00.B
	•		•	5-12 V ac/dc	10.0.00.J	20.0.00.J
	•			12 V dc	10.0.00.E	20.0.00.E
	•			24 V dc	10.0.00.F	20.0.00.F
		•		8-14 V ac/dc	10.1.00.B	20.1.00.B
		•		5-12 V ac/dc	10.1.00.J	20.1.00.J
		•		12 V dc	10.1.00.E	20.1.00.E
		•		24 V dc	10.1.00.F	20.1.00.F
			•	8-14 V ac/dc	11.0.00.B	21.0.00.B
			•	5-12 V ac/dc	11.0.00.J	21.0.00.J
				12 V dc	11.0.00.E	21.0.00.E
				24 V dc	11.0.00.F	21.0.00.F
		•	•	8-14 V ac/dc	11.1.00.B	21.1.00.B
		•	•	5-12 V ac/dc	11.1.00.J	21.1.00.J
		•	•	12 V dc	11.1.00.E	21.1.00.E
		•	•	24 V dc	11.1.00.F	21.1.00.F
			•	8-14 V ac/dc	12.0.00.B	22.0.00.B
			•	5-12 V ac/dc	12.0.00.J	22.0.00.J
				8-14 V ac/dc	12.1.00.B	22.1.00.B
				5-12 V ac/dc	12.1.00.J	22.1.00.J
		•	•	9-14 V ac/dc	12A.0.00.B	22A.0.00.B
		•	•	6-12 V ac/dc	12A.0.00.J	22A.0.00.J
			•	9-14 V ac/dc	12A.1.00.B	22A.1.00.B
			•	6-12 V ac/dc	12A.1.00.J	22A.1.00.J
			•	8-14 V ac/dc	13.0.00.B	23.0.00.B
			•	5-12 V ac/dc	13.0.00.J	23.0.00.J
				8-14 V ac/dc	13.1.00.B	23.1.00.B
				5-12 V ac/dc	13.1.00.J	23.1.00.J
		•	•	9-14 V ac/dc	13A.0.00.B	23A.0.00.B
		•	•	6-12 V ac/dc	13A.0.00.J	23A.0.00.J
			•	9-14 V ac/dc	13A.1.00.B	23A.1.00.B
			•	6-12 V ac/dc	13A.1.00.J	23A.1.00.J

Recommended Faceplates

SHORT	LONG	ANGLED
01 Grey	03 Grey Brown	08 Brown
61 Inox	04 Grey Brown	09 Brown
66 Inox	05 Grey Brown	10 Brown
	20 Inox	11 Brown
BOX	21 Inox	12 Brown
	43 Inox	13 Brown
80 Grey	63 Inox	14 Brown
81 Grey	64 Inox	15 Brown
	65 Inox	16 Brown
84 Grey	67 Inox	17 Brown
Chrome	73 Inox	
Brass	74 Inox	
	C63 Inox	
	C64 Inox	
	C65 Inox	
	D3 Grey Brown	
	D4 Grey Brown	

Shallow adjustable keeper

Supplied upon request

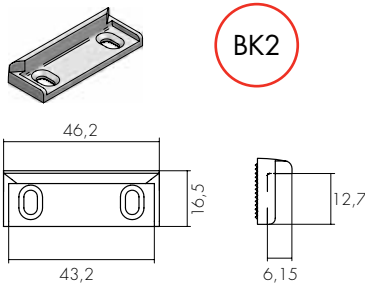

Deep adjustable keeper

Supplied upon request

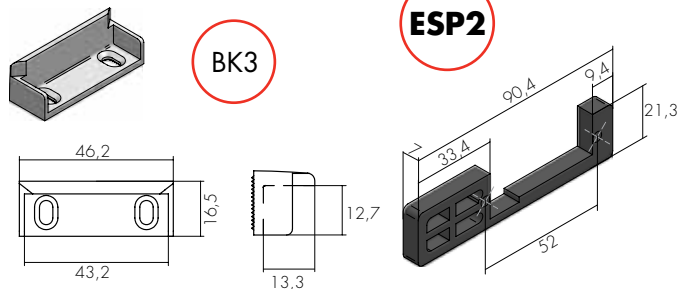

Shim kit

ESP2

Dimensions

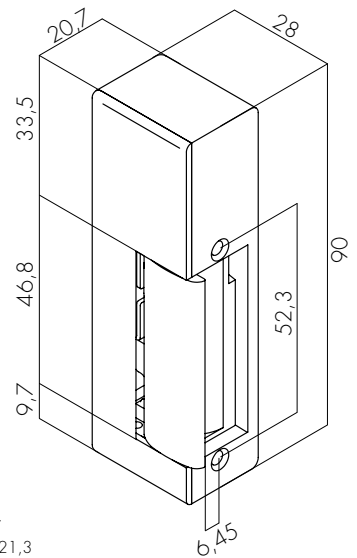

Keeper's adjustability: 3 mm



SYMMETRIC

Series 3

Symmetrical electric strikes are the most common on the market. They are **100% reversible** and feature an adjustable keeper.

DC models are equipped with electronic protection in order to prevent damages to your access control system. This also represents an advantage for the installer as the connection is not polarized.

Featuring a wide variety of functions and voltages, these strikes quickly unlock standard doors through low power consumption.

Technical Features

- Max. side-load on AC: 160 N
Max. side-load on DC: 10 N
- Break-in resistance: 3.000 N
- Operating temperature range: -15 °C /+40 °C
- Housing: Zamak
Keeper: Zamak
- Guaranteed 3 years
- Complies with 2004/108/CE (EN 55014)
- Corrosion resistant according to UNI ISO 9227

Coil features

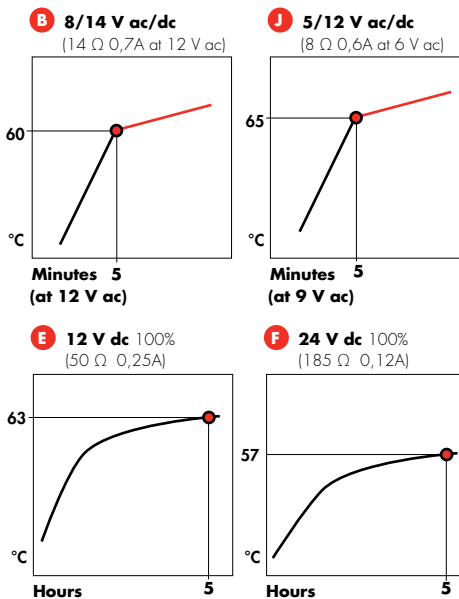

Personalized coils upon request

References and features

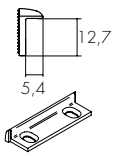

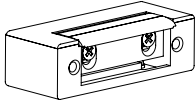
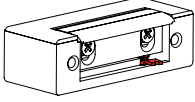
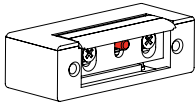
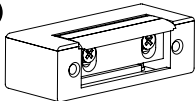
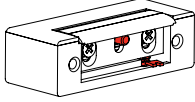
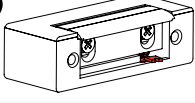
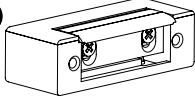
		Reversible	Adjustable keeper	Side-load	Electronic protection	Voltage	References add faceplate
	Fail-secure	●	●	●		8-14 V ac/dc	30.1.00.B
		●	●	●		5-12 V ac/dc	30.1.00.J
		●	●		●	12 V dc	30.1.00.E
		●	●		●	24 V dc	30.1.00.F
	Fail-Secure with mechanical unlocking	●	●	●		8-14 V ac/dc	31.1.00.B
		●	●	●		5-12 V ac/dc	31.1.00.J
		●	●		●	12 V dc	31.1.00.E
		●	●		●	24 V dc	31.1.00.F
	Hold-open	●	●	●		8-14 V ac/dc	32.1.00.B
		●	●	●		5-12 V ac/dc	32.1.00.J
		●	●		●	12 V dc	32.1.00.E
	Internal Hold-open	●	●	●		9-14 V ac/dc	32A.1.00.B
		●	●	●		6-12 V ac/dc	32A.1.00.J
	Hold-open with mechanical unlocking	●	●	●		8-14 V ac/dc	33.1.00.B
		●	●	●		5-12 V ac/dc	33.1.00.J
		●	●		●	12 V dc	33.1.00.E
	Internal Hold-open with mechanical unlocking	●	●	●		9-14 V ac/dc	33A.1.00.B
		●	●	●		6-12 V ac/dc	33A.1.00.J
	Fail-safe	●	●		●	12 V dc	34.1.00.E
		●	●		●	24 V dc	34.1.00.F

Recommended Faceplates

SHORT	LONG	ANGLED
01 Grey	04 Grey Brown	08 Brown
02 Grey	05 Grey Brown	09 Brown
61 Inox	20 Inox	12 Brown
62 Inox	21 Inox	13 Brown
66 Inox	64 Inox	16 Brown
92 Inox	65 Inox	17 Brown
	71 Inox	
BOX	73 Inox	
81 Grey	74 Inox	
	C64 Inox	
84 Grey	C65 Inox	
Chrome	D4 Grey Brown	
Brass		

Deep adjustable keeper

Supplied upon request

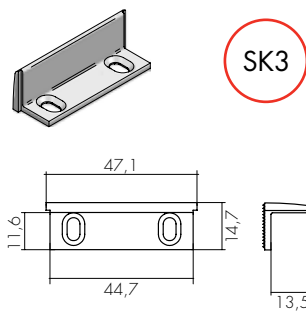

SK3

Shim kit installation

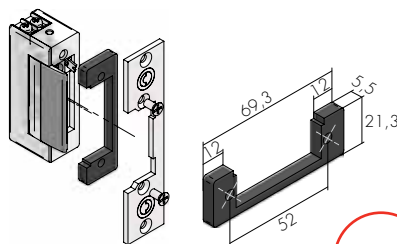

ESP3

Dimensions

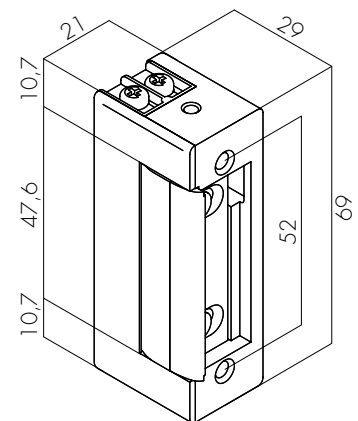

Keeper's adjustability: 3 mm



MINI

Series 5

This 100% reversible electric strike - **only 16 mm wide** - is one of the smallest on the market and the perfect match for narrow profiles such as aluminum, wood and PVC. Through its small size and high resistance it can fit any lock.

The radial keeper rotates inside the mechanism box of the electric strike, so the installer does not have to cut the door frame to make it fit.

All models are equipped with electronic protection to prevent damage to the access control system they are connected to. This also represents an advantage for the installer as the connection is not polarized.

Featuring a wide variety of functions and voltages, these strikes quickly unlock standard doors through low power consumption.

Technical features

- Max. side-load on AC: 160 N
Max. side-load on DC: 10 N
- Break-in resistance: 4.000 N
- Operating temperature range: -15 °C /+40 °C
- Housing: Zamak
Keeper: Zamak
- New hold-open system
- Guaranteed 3 years
- Complies with 2004/108/CE (EN 55014)
- Corrosion resistant according to UNI ISO 9227

Coil features

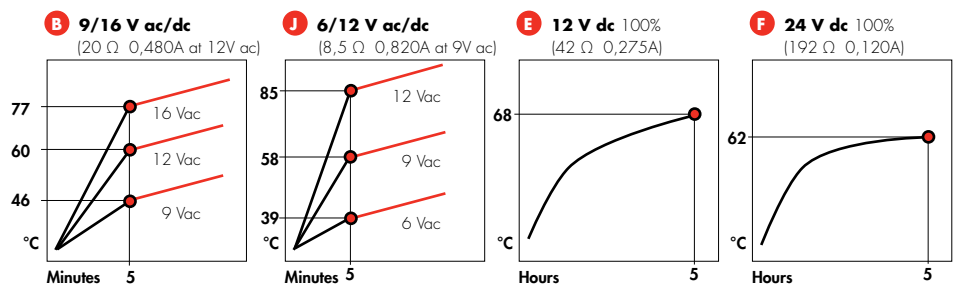

Personalized coils upon request

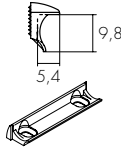

References and features

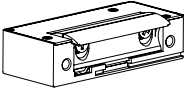
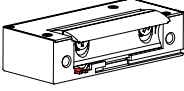
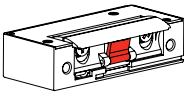
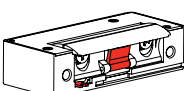
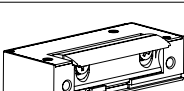
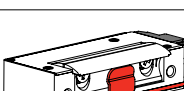
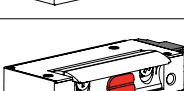
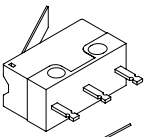
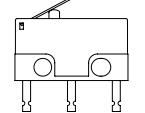
		Radial adjustable keeper	Reversible	Side-load	Electronic protection	Voltage	References <small>add faceplate</small>
	Fail-secure	●	●	●	●	9-16 V ac/dc	50.1.00.B
		●	●	●	●	6-12 V ac/dc	50.1.00.J
		●	●	●	●	12 V dc	50.1.00.E
		●	●	●	●	24 V dc	50.1.00.F
	Fail-secure with mechanical unlocking	●	●	●	●	9-16 V ac/dc	51.1.00.B
		●	●	●	●	6-12 V ac/dc	51.1.00.J
		●	●	●	●	12 V dc	51.1.00.E
	Hold-open	●	●	●	●	9-16 V ac/dc	52.1.00.B
		●	●	●	●	6-12 V ac/dc	52.1.00.J
		●	●	●	●	24 V dc	52.1.00.F
	Hold-open with mechanical unlocking	●	●	●	●	9-16 V ac/dc	53.1.00.B
		●	●	●	●	6-12 V ac/dc	53.1.00.J
	Fail-safe	●	●	●	●	12 V dc	54.1.00.E
		●	●	●	●	24 V dc	54.1.00.F
	Fail-secure with monitoring	●	●	●	●	9-16 V ac/dc	56.1.00.B
		●	●	●	●	6-12 V ac/dc	56.1.00.J
		●	●	●	●	12 V dc	56.1.00.E
		●	●	●	●	24 V dc	56.1.00.F
	Fail-safe with monitoring	●	●	●	●	12 V dc	58.1.00.E
		●	●	●	●	24 V dc	58.1.00.F
Monitoring features:		Intensity		1A/125V AC 0,5A/30V DC			
		Operating Speed		1 at 500 mm/second (at pin plunger)			
Microswitch S1		Operating Frequency		Mechanical: 200 operations per minute Electrical: 30 operations per minute			
		Contact Resistance		50 mΩ maximum			
		Insulation Resistance		100 MΩ minimum (at 500V DC)			
		Ambient Temperature		From -25°C to 65°C (without ice)			
		Humidity		85% RH maximum (5° to 35°C)			
		Life Expectancy*		Mechanical: 300.000 operations minimum Electrical: 30.000 operations minimum			

*at maximum power conditions

Recommended Faceplates

SHORT	LONG	ANGLED
27 Inox	22 Inox	24 Inox
28 Inox	23 Inox	25 Inox
	26 Inox	
	29 Inox	
	30 Inox	

Dimensions

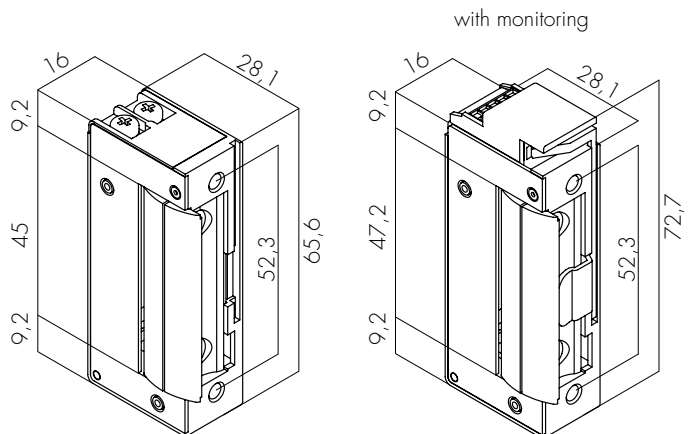

Keeper's adjustability: 2 mm

RIM

Series 1 & 2 RIM



Rim strikes are built with a cavity designed to house the dead bolt of rim locks.

They are available for either DIN right or left doors, for both horizontal (90 mm) and vertical (120 mm) mechanical locks.

Featuring a wide variety of functions and voltages, these strikes quickly unlock standard doors through low power consumption.

Technical features

- Max. side-load on AC: 160 N
Max. side-load on DC: 10 N
- Break-in resistance: 5.000 N
- Operating temperature range: -15 °C /+40 °C
- Housing: Black painted aluminium
Keeper: Zamak
- Maximum distance between the bolt and the latch: 5mm
- Guaranteed 3 years
- Complies with 2004/108/CE (EN 55014)
- Corrosion resistant according to UNI ISO 9227

Coil features

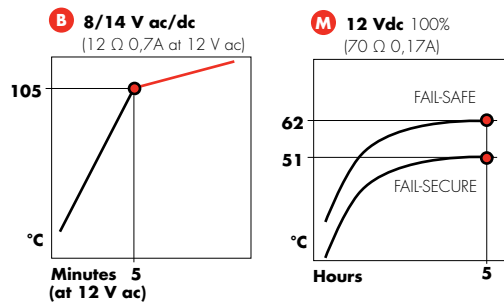

Personalized coils upon request

References and features

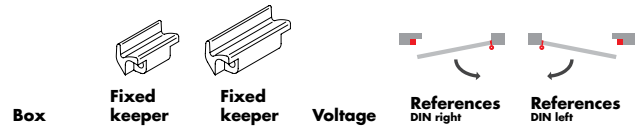

	Box	Fixed keeper	Fixed keeper	Voltage	References DIN right	References DIN left
<p>Fail-secure</p>	90 mm	●		8-14 V ac/dc	10.0.9B.B	20.0.9A.B
	120 mm		●	8-14 V ac/dc	10.0.12A.B	20.0.12B.B
<p>Internal Hold-open</p>	90 mm	●		9-14 V ac/dc	12A.0.9B.B	22A.0.9A.B
	120 mm		●	9-14 V ac/dc	12A.0.12A.B	22A.0.12B.B
<p>Fail-safe</p>	90 mm	●		12 V dc	14.0.9B.M	24.0.9A.M
	120 mm		●	12 V dc	14.0.12A.M	24.0.12B.M

Dimensions

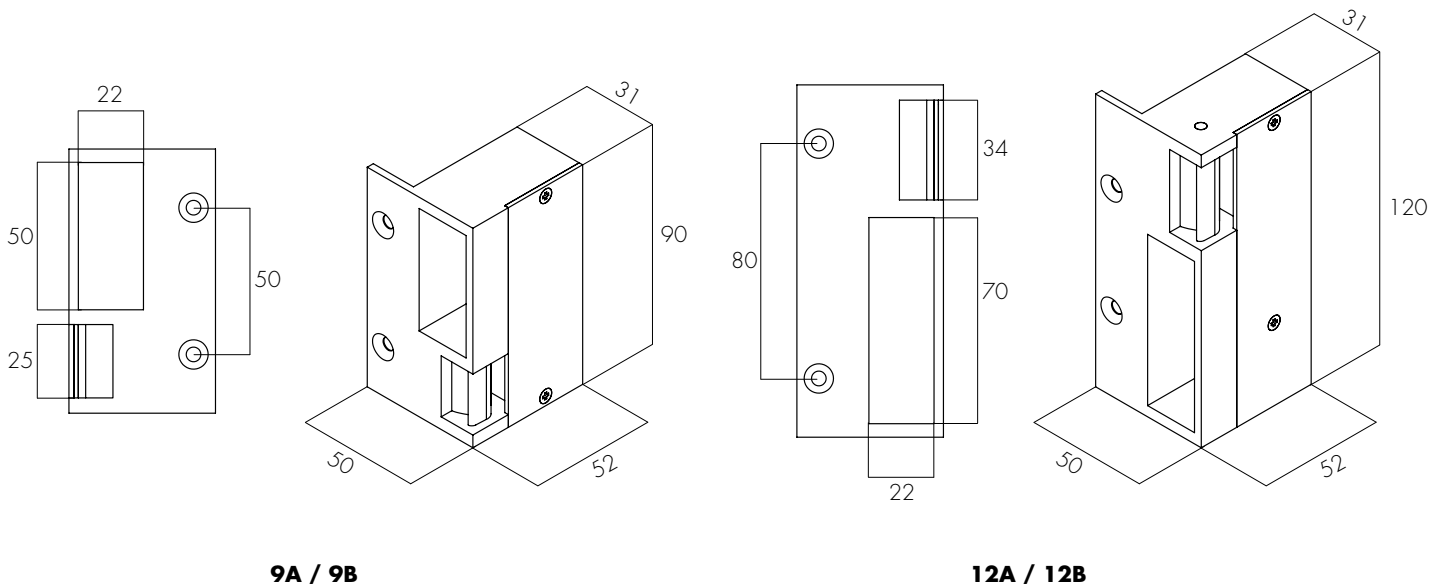

IP54



WATERPROOF

Series 7R & 7L

Waterproof electric strikes are designed for **outdoor installations** particularly in wet or dusty areas. The curved design of the base of the box allows the installation of locks where the separation between the latch and the first bolt is only 5 mm.

The model with monitoring operates by magnetism and it is an O&C patented system which ensures the insulation of the reed box.

DC models are equipped with electronic protection in order to prevent damages to your access control system. This also represents an advantage for the installer as the connection is not polarized.

Manufactured for right and left opening doors and featuring a wide variety of functions and voltages, these strikes quickly unlock standard doors through low power consumption.

Technical features

- Max. side-load on AC: 160 N
Max. side-load on DC: 10 N
- Break-in resistance: 5.000 N
- Operating temperature range: -15 °C /+40 °C
- Housing: Zamak
Keeper: Zamak
- Guaranteed 3 years
- Complies with 2004/108/CE (EN 55014)
- Corrosion resistant according to UNI ISO 9227

Certifications

- IP 54 certified (protected against dust and water)

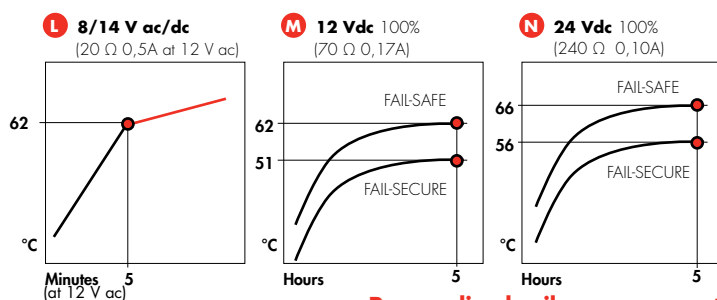

Coil features

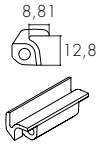

Personalized coils upon request

References and features

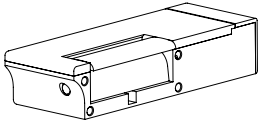
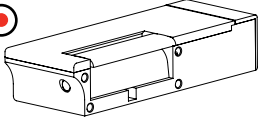
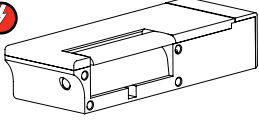
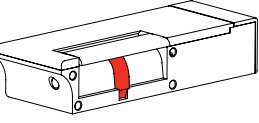
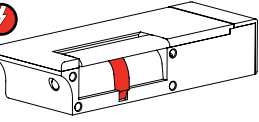

	Fixed keeper	Side-load	Electronic protection	Voltage	References DIN right add faceplate	References DIN left add faceplate
 Fail-secure	●	●		8-14 V ac/dc	7R0.4.00.L	7L0.4.00.L
	●		●	12 V dc	7R0.4.00.M	7L0.4.00.M
	●		●	24 V dc	7R0.4.00.N	7L0.4.00.N
 Internal Hold-open	●	●		9-14 V ac/dc	7R2A.4.00.L	7L2A.4.00.L
 Fail-safe	●		●	12 V dc	7R4.4.00.M	7L4.4.00.M
	●		●	24 V dc	7R4.4.00.N	7L4.4.00.N
 Fail-secure with monitoring	●	●		8-14 V ac/dc	7R6.4.00.L	7L6.4.00.L
	●		●	12 V dc	7R6.4.00.M	7L6.4.00.M
	●		●	24 V dc	7R6.4.00.N	7L6.4.00.N
 Fail-safe with monitoring	●		●	12 V dc	7R8.4.00.M	7L8.4.00.M
	●		●	24 V dc	7R8.4.00.N	7L8.4.00.N
 REED			Maximum voltage	100 V DC		
			Maximum current	0,3 A		
			Maximum power	3 W		

Recommended Faceplates

SHORT	LONG
76 Inox	68 Inox
	69 Inox
	75 Inox

Dimensions

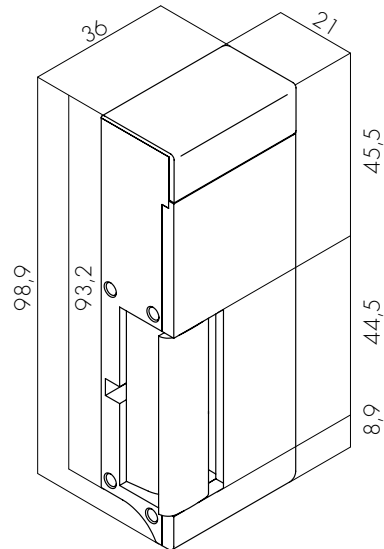



ARMoured

Series 9R & 9L

These electric strikes have been especially designed for armoured doors secured by **multipoint locks** where the separation between the latch and the first bolt is only 5mm.

DC models are equipped with electronic protection in order to prevent damages to your access control system. This also represents an advantage for the installer as the connection is not polarized.

Featuring a wide variety of functions and voltages, these strikes quickly unlock standard doors through low power consumption.

Technical features

- Max. side-load on AC: 160 N
Max. side-load on DC: 10 N
- Break-in resistance: 7.000 N
- Operating temperature range: -15 °C / +40 °C
- Housing: Zamak
Keeper: Zamak
- Patented coil-fastening system
- Guaranteed 3 years
- Complies with 2004/108/CE (EN 55014)
- Corrosion resistant according to UNI ISO 9227

Coil features

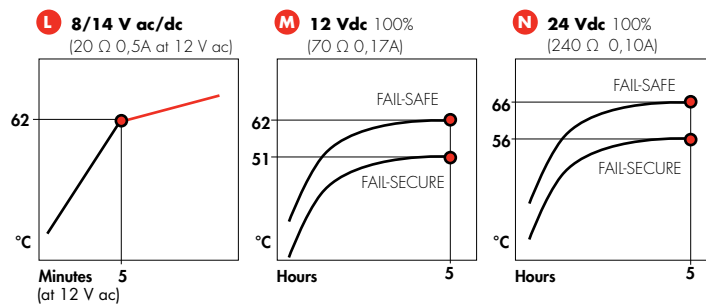

Personalized coils upon request

References and features

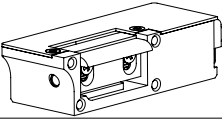
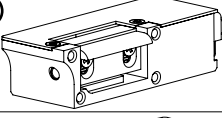
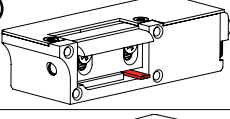
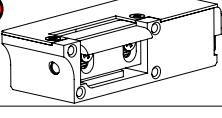
		Adjustable keeper	Side-load	Electronic protection	Voltage	References DIN right add faceplate	References DIN left add faceplate
 Fail-secure		●	●		8-14 V ac/dc	9R0.1.00.L	9L0.1.00.L
		●		●	12 V dc	9R0.1.00.M	9L0.1.00.M
		●		●	24 V dc	9R0.1.00.N	9L0.1.00.N
 Internal Hold-open		●	●		9-14 V ac/dc	9R2A.1.00.L	9L2A.1.00.L
 Internal Hold-open with mechanical unlocking		●	●		9-14 V ac/dc	9R3A.1.00.L	9L3A.1.00.L
 Fail-safe		●		●	12 V dc	9R4.1.00.M	9L4.1.00.M
		●		●	24 V dc	9R4.1.00.N	9L4.1.00.N

Recommended Faceplates

LONG

60 Inox
70 Inox

Deep adjustable keeper
Supplied upon request

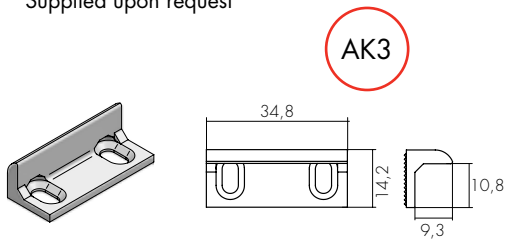

Dimensions

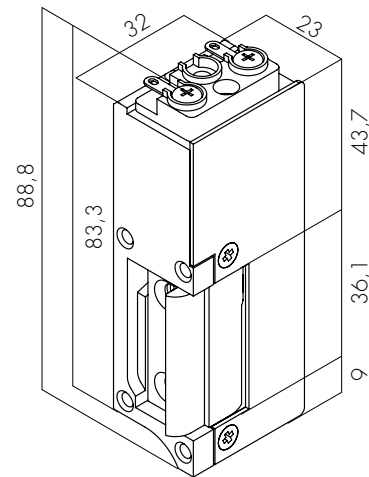

Keeper's adjustability: 3 mm

EMERGENCY

Series 4

These strikes are designed to be installed on emergency exit doors equipped with **panic bars** and allow the access from outside through an access control system.

Ideal for doors that require high level of reliability and safety, these strikes are usually connected with fire control systems.

DC models are equipped with electronic protection in order to prevent damages to your access control system. This also represents an advantage for the installer as the connection is not polarized.

Featuring a wide variety of functions and voltages, these strikes quickly unlock standard doors through low power consumption.

Technical features

- Max. side-load on AC: 160 N
Max. side-load on DC: 10 N
- Break-in resistance: 7.000 N
- Operating temperature range: -15 °C /+40 °C
- Housing: Zamak
Keeper: Zamak
- Patented coil-fastening system
- Guaranteed 3 years
- Complies with 2004/108/CE (EN 55014)
- Corrosion resistant according to UNI ISO 9227

Coil features

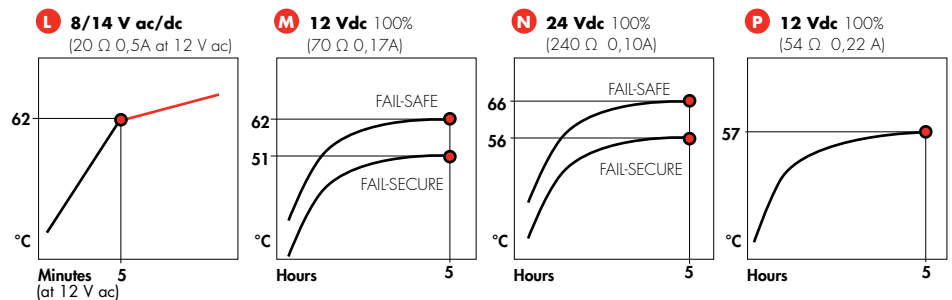

Personalized coils upon request

References and features

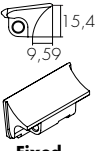

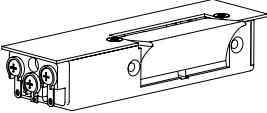
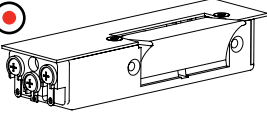
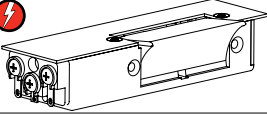
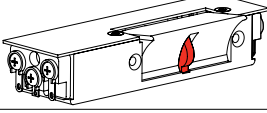
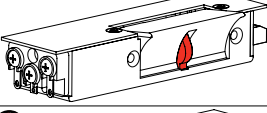
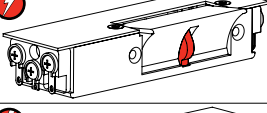
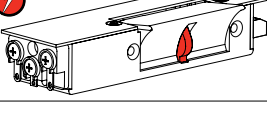
	Symmetrical reversibility	Fixed keeper	Side-load	Electronic protection	Voltage	References add box
 Fail-secure	●	●	●		8-14 V ac/dc	40.6.00.L
	●	●		●	12 V dc	40.6.00.M
	●	●		●	24 V dc	40.6.00.N
 Internal Hold-open	●	●	●		9-14 V ac/dc	42A.6.00.L
 Fail-safe	●	●		●	12 V dc	44.6.00.M
	●	●		●	24 V dc	44.6.00.N
 Fail-secure with monitoring	●	●	●		8-14 V ac/dc	46.6.00.L
	●	●		●	12 V dc	46.6.00.M
	●	●		●	24 V dc	46.6.00.N
 Fail-secure with double monitoring	●	●		●	12 V dc	47.6.00.P
	●	●		●	24 V dc	47.6.00.N
 Fail-safe with monitoring	●	●		●	12 V dc	48.6.00.M
	●	●		●	24 V dc	48.6.00.N
 Fail-safe with double monitoring	●	●		●	12 V dc	49.6.00.P
	●	●		●	24 V dc	49.6.00.N

Monitoring features:

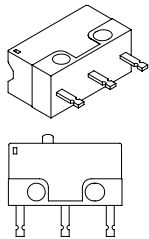

Microswitch S1

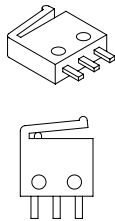

Microswitch S2

	Microswitch S1	Microswitch S2
Intensity	1A/125V AC 0,5A/30V DC	0,5A/30V DC
Operating Speed	1 at 500 mm/second (at pin plunger)	1 at 500 mm/second (at pin plunger)
Operating Frequency	Mechanical: 200 operations per minute Electrical: 30 operations per minute	Mechanical: 200 operations per minute Electrical: 30 operations per minute
Contact Resistance	50 mΩ maximum	30 mΩ maximum
Insulation Resistance	100 MΩ minimum (at 500V DC)	100 MΩ minimum (at 500V DC)
Ambient Temperature	From -25°C to 65°C (without ice)	From -25°C to 70°C (without ice)
Humidity	85% RH maximum (5° to 35°C)	85% RH maximum (5° to 35°C)
Protection degree		IP 40
Life Expectancy*	Mechanical: 300.000 operations minimum Electrical: 30.000 operations minimum	Mechanical: 30.000 operations minimum Electrical: 30.000 operations minimum

*at maximum power conditions

Recommended Boxes

BOX

- 82 Black
- 83 Black + C83
- 85 Black + Base + C83

Dimensions

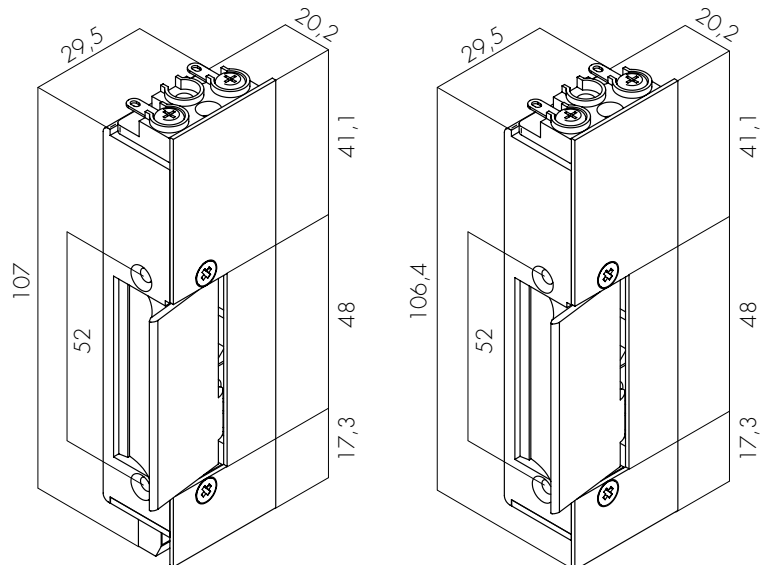

with double monitoring



SECURITY

Series 4R & 4L

Security electric strikes are designed for doors connected to fire and **access control systems** or doors requiring a high level of security.

The zamak housing has been reinforced, in order to ensure higher resistance. The keeper is anchored through four support points.

DC models are equipped with electronic protection in order to prevent damages to your access control system. This also represents an advantage for the installer as the connection is not polarized.

They are manufactured for both right and left opening doors featuring a wide variety of functions and voltages, these strikes quickly unlock standard doors through low power consumption.

Technical features

- Max. side-load on AC: 160 N
Max. side-load on DC: 10 N
- Break-in resistance: 7.000 N
- Operating temperature range: -15 °C / +40 °C
- Housing: Reinforced Zamak
Keeper: Steel
- Guaranteed 3 years.
- Complies with 2004/108/CE (EN 55014)
- Corrosion resistant according to UNI ISO 9227

Coil features

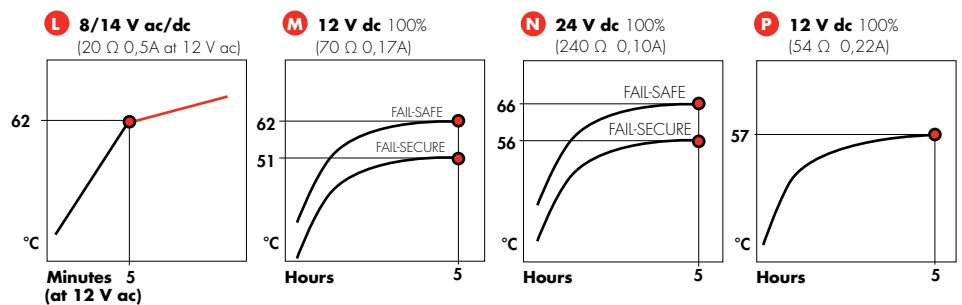

Personalized coils upon request

References and features

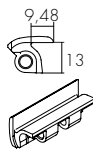

Fixed keeper

Side-load

Electronic protection

Voltage



References DIN right add faceplate

References DIN left add faceplate

	Fail-secure	●	●		8-14 V ac/dc	4R0.4.00.L	4L0.4.00.L
		●		●	12 V dc	4R0.4.00.M	4L0.4.00.M
		●		●	24 V dc	4R0.4.00.N	4L0.4.00.N
	Internal Hold-open	●	●		9-14 V ac/dc	4R2A.4.00.L	4L2A.4.00.L
	Fail-safe	●		●	12 V dc	4R4.4.00.M	4L4.4.00.M
		●		●	24 V dc	4R4.4.00.N	4L4.4.00.N
	Fail-secure with monitoring	●	●		8-14 V ac/dc	4R6.4.00.L	4L6.4.00.L
		●		●	12 V dc	4R6.4.00.M	4L6.4.00.M
		●		●	24 V dc	4R6.4.00.N	4L6.4.00.N
	Fail-secure with double monitoring	●		●	12 V dc		47.4.00.P
		●		●	24 V dc		47.4.00.N
	Fail-safe with monitoring	●		●	12 V dc	4R8.4.00.M	4L8.4.00.M
		●		●	24 V dc	4R8.4.00.N	4L8.4.00.N
	Fail-safe with double monitoring	●		●	12 V dc		49.4.00.P
		●		●	24 V dc		49.4.00.N

Monitoring features:

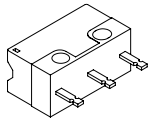

Microswitch S1

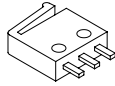

Microswitch S2

	Microswitch S1	Microswitch S2
Intensity	1A/125V AC 0,5A/30V DC	0,5A/30V DC
Operating Speed	1 at 500 mm/second (at pin plunger)	1 at 500 mm/second (at pin plunger)
Operating Frequency	Mechanical: 200 operations per minute Electrical: 30 operations per minute	Mechanical: 200 operations per minute Electrical: 30 operations per minute
Contact Resistance	50 mΩ maximum	30 mΩ maximum
Insulation Resistance	100 MΩ minimum (at 500V DC)	100 MΩ minimum (at 500V DC)
Ambient Temperature	From -25°C to 65°C (without ice)	From -25°C to 70°C (without ice)
Humidity	85% RH maximum (5° to 35°C)	85% RH maximum (5° to 35°C)
Protection degree		IP 40
Life Expectancy*	Mechanical: 300.000 operations minimum Electrical: 30.000 operations minimum	Mechanical: 30.000 operations minimum Electrical: 30.000 operations minimum

*at maximum power conditions

Recommended Faceplates

SHORT

61 Inox
66 Inox

LONG

43 Inox
67 Inox
71 Inox

ANGLED

16 Brown
17 Brown
45 Brown
48 Brown
49 Inox
50 Inox

Dimensions

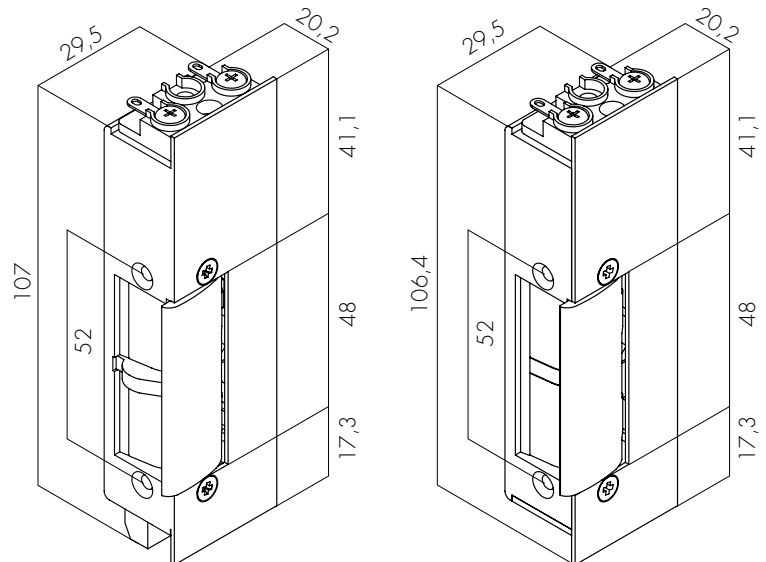

with double monitoring



HIGH-SECURITY

Series 25

High-security electric strikes are considered one of the smallest and still **strongest strikes on the market**, the perfect solution for installations where high-performances are required.

They are 100% reversible and feature an adjustable keeper. The radial keeper rotates inside the mechanism box of the electric strike, so the installer does not have to cut the door frame to make it fit.

All models are equipped with electronic protection to prevent damage to the access control system they are connected to. This also represents an advantage for the installer as the connection is not polarized.

Featuring a wide variety of functions and voltages, these strikes quickly unlock standard doors through low power consumption.

Technical features

- Max. side-load on AC: 160 N
Max. side-load on DC: 10 N
- Break-in resistance: 10.000 N
- Operating temperature range: -15 °C /+40 °C
- Housing: Steel
Keeper: Stainless Steel
- New hold-open system
- Guaranteed 3 years
- Complies with 2004/108/CE (EN 55014)
- Corrosion resistant according to UNI ISO 9227

Coil features

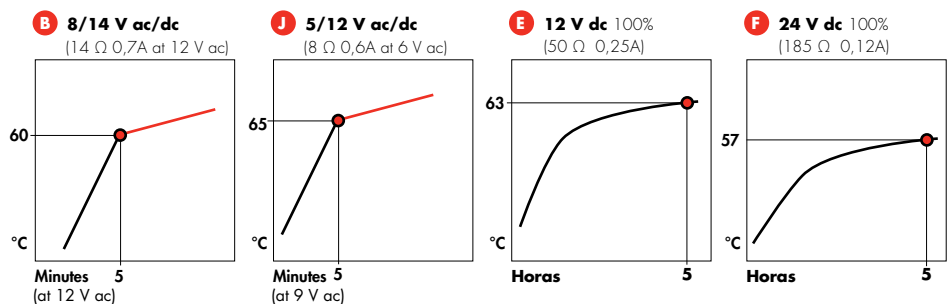

Personalized coils upon request

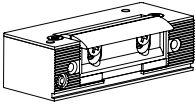
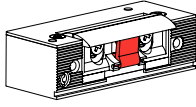
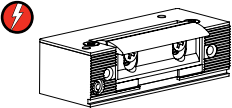
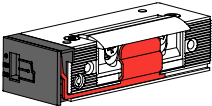
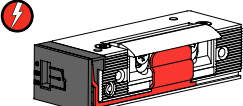

References and features

		Radial adjustable keeper	Reversible	Side-load	Electronic protection	Voltage	References add faceplate
	Fail-secure	•	•	•	•	8-14 V ac/dc	250.1.00.B
		•	•	•	•	5-12 V ac/dc	250.1.00.J
		•	•		•	12 V dc	250.1.00.E
		•	•		•	24 V dc	250.1.00.F
	Hold-open	•	•	•	•	8-14 V ac/dc	252.1.00.B
		•	•	•	•	5-12 V ac/dc	252.1.00.J
	Fail-safe	•	•		•	12 V dc	254.1.00.E
		•	•		•	24 V dc	254.1.00.F
	Fail-secure with monitoring	•	•	•	•	8-14 V ac/dc	256.1.00.B
		•	•	•	•	5-12 V ac/dc	256.1.00.J
		•	•		•	12 V dc	256.1.00.E
		•	•		•	24 V dc	256.1.00.F
	Fail-safe with monitoring	•	•		•	12 V dc	258.1.00.E
		•	•		•	24 V dc	258.1.00.F

Monitoring features:

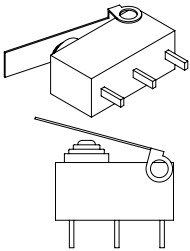

Microswitch S3

Intensity	0,1A/125V AC 2A/12V DC
Operating Speed	1 at 500 mm/second (at pin plunger)
Operating Frequency	Electrical: 30 operations per minute
Contact Resistance	100 mΩ maximum
Insulation Resistance	100 MΩ minimum (at 500V DC)
Ambient Temperature	From -40°C to 85°C (without ice)
Humidity	95% RH maximum (5° to 35°C)
Protection degree	IEC IP 67 (excluding the terminal)
Life Expectancy*	Mechanical: 1.000.000 operations minimum (30 operations per minute) Electrical: 100.000 operations minimum (20 operations per minute)

*at maximum power conditions

Recommended Faceplates

SHORT	LONG	ANGLED
61 Inox	43 Inox	16 Brown
66 Inox	63 Inox	17 Brown
92 Inox	67 Inox	45 Brown
	71 Inox	48 Brown
	C63 Inox	49 Inox
		50 Inox

Dimensions

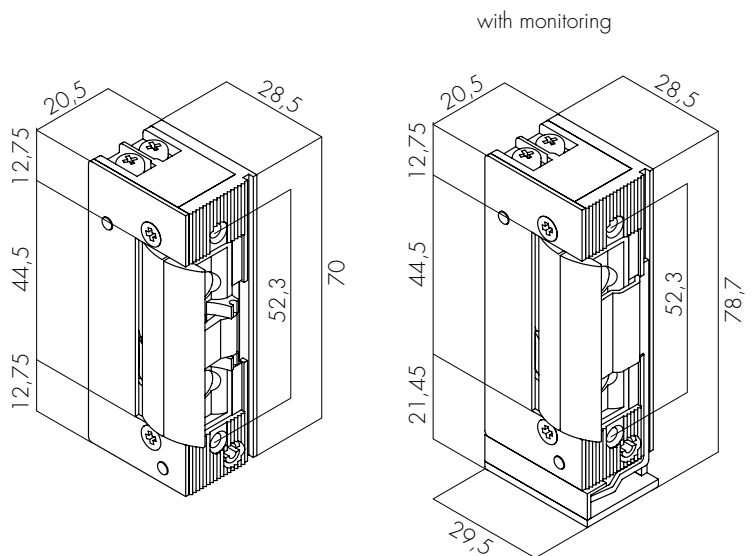

Keeper's adjustability: 3 mm



FIRE

Series 24R & 24L

RF-120 electric strikes are manufactured to resist temperatures above 1.100 °C for 120 minutes and are the ideal strikes for **fire door systems**.

DC models are equipped with electronic protection in order to prevent damages to your access control system. This also represents an advantage for the installer as the connection is not polarized.

Manufactured for left and right DIN opening doors and featuring a wide variety of functions and voltages, these strikes quickly unlock fire doors through low power consumption.

Technical features

- Max. side-load on AC: 160 N
Max. side-load on DC: 10 N
- Break-in resistance: 10.000 N
- Operating temperature range: -15 °C / +40 °C
- Housing: Steel
Keeper: Steel
- Guaranteed 3 years
- Complies with 2004/108/CE (EN 55014)
- Corrosion resistant according to UNI ISO 9227

Certifications

- UNE EN 1634-1, RF-120

Coil features

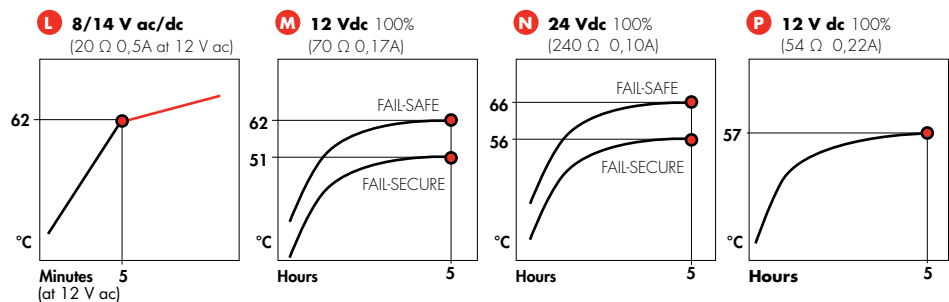

Personalized coils upon request

References and features

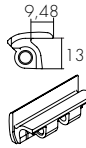

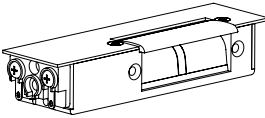
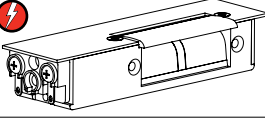
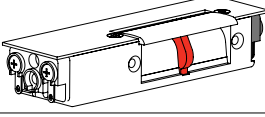
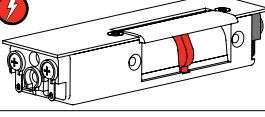
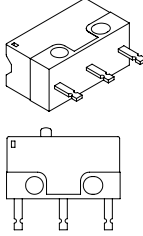
	Fixed keeper	Side-load	Electronic protection	Voltage	References DIN right add faceplate	References DIN left add faceplate
 Fail-secure	●	●		8-14 V ac/dc	24R0.4.00.L	24L0.4.00.L
	●		●	12 V dc	24R0.4.00.M	24L0.4.00.M
	●		●	24 V dc	24R0.4.00.N	24L0.4.00.N
 Fail-safe	●		●	12 V dc	24R4.4.00.P	24L4.4.00.P
	●		●	24 V dc	24R4.4.00.N	24L4.4.00.N
 Fail-secure with monitoring	●	●		8-14 V ac/dc	24R6.4.00.L	24L6.4.00.L
	●		●	12 V dc	24R6.4.00.M	24L6.4.00.M
	●		●	24 V dc	24R6.4.00.N	24L6.4.00.N
 Fail-safe with monitoring	●		●	12 V dc	24R8.4.00.P	24L8.4.00.P
	●		●	24 V dc	24R8.4.00.N	24L8.4.00.N
Monitoring features:	Intensity 1A/125V AC 0.5A/30V DC					
 Microswitch S1	Operating Speed 1 at 500 mm/second (at pin plunger)					
	Operating Frequency Mechanical: 200 operations per minute Electrical: 30 operations per minute					
	Contact Resistance 50 mΩ maximum					
	Insulation Resistance 100 MΩ minimum [at 500V DC]					
	Ambient Temperature From -25°C to 65°C (without ice)					
	Humidity 85% RH maximum (5° to 35°C)					
	Life Expectancy* Mechanical: 300.000 operations minimum Electrical: 30.000 operations minimum					

*at maximum power conditions

Recommended Faceplates

SHORT

61 Inox
66 Inox

LONG

43 Inox
67 Inox
71 Inox

Dimensions

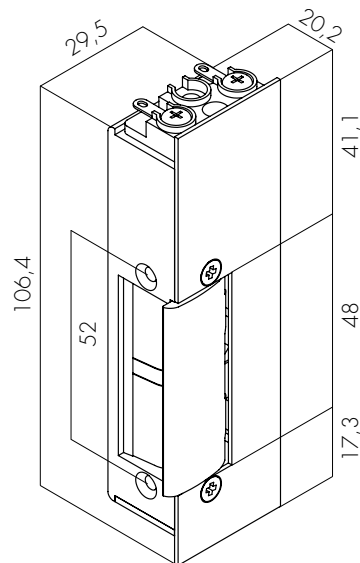

FACEPLATES

Type	Faceplate	Color	Reversible	DIN Left	DIN Right	BASIC	SYMMETRIC	MINI	SECURITY	HIGH SECURITY	WATERPROOF	FIRE	EMERGENCY	ARMOURED	
Short	01	Grey	•			•	•								
	02	Grey	•				•								
	27	Inox	•					•							
	28	Inox	•					•							
	61	Inox	•			•	•		•	•		•			
	62	Inox	•			•	•								
	66	Inox	•			•			•	•		•			
	76	Inox	•								•				
	92	Inox	•					•		•					
Boxes	80	Grey	•			•									
	81	Grey	•			•	•								
	82	Black	•										•		
	83 + C83	Black	•										•		
	84	Grey Chrome Brass	•			•	•								
	85 + Base + C83	Black	•										•		
C83 (6 unit accessory for boxes 83/85)															
Long	03	Grey Brown	•			•									
	04	Grey Brown	•			•	•								
	05	Grey Brown	•			•	•								
	20	Inox			•	•	•								
	21	Inox		•		•	•								
	22	Inox			•			•							
	23	Inox		•				•							
	26	Inox	•					•							
	29	Inox	•					•							
	30	Inox	•					•							
	43	Inox	•			•			•	•		•			
	60	Inox	•											•	
	63	Inox	•			•				•					
	64	Inox	•			•		•							
	65	Inox	•			•		•							
	67	Inox	•			•			•	•		•			
	68	Inox	•								•				
	69	Inox	•								•				
	70	Inox	•											•	
	71	Inox	•					•					•		
	73	Inox			•	•	•	•							
	74	Inox		•		•	•	•							
	75	Inox	•								•				
	C63	Inox	•			•	•				•				
C64	Inox	•			•	•	•								
C65	Inox	•			•	•	•								
D3	Grey Brown	•			•	•									
D4	Grey Brown	•			•	•	•								
Angled	08	Brown			•	•	•								
	09	Brown		•		•	•								
	10	Brown			•	•									
	11	Brown		•		•									
	12	Brown			•	•	•								
	13	Brown		•		•	•								
	14	Brown			•	•									
	15	Brown		•		•									
	16	Brown	•			•	•	•	•	•					
	17	Brown	•			•	•	•	•	•					
	24	Inox			•				•						
	25	Inox		•					•						
	45	Brown			•				•	•					
	48	Brown		•					•	•					
	NEW	49	Inox			•			•	•					
NEW	50	Inox		•				•	•						

SHORT

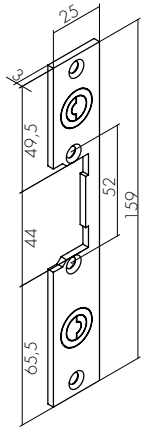

Reversible

01 GREY

61 INOX
3mm

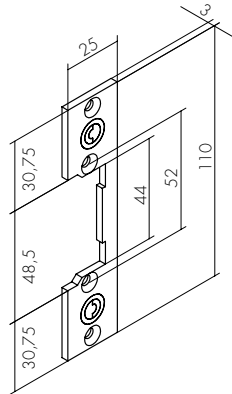

Reversible

02 GREY

62 INOX
3mm

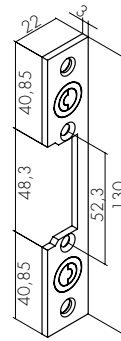

Reversible

27 INOX
3mm

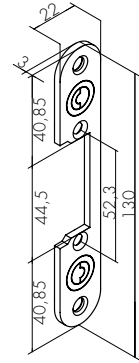

Reversible

28 INOX
3mm

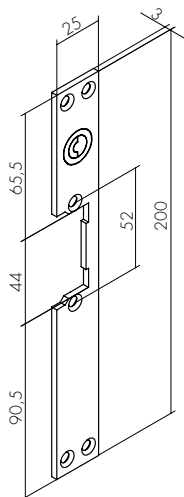

Reversible

66 INOX
3mm

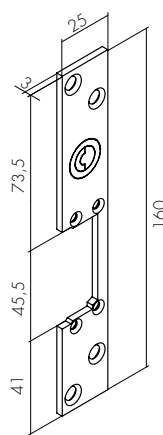

Reversible

76 INOX
3mm

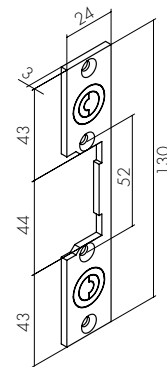

Reversible

92 INOX
3mm

BOXES

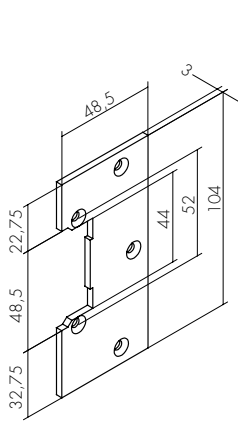

Reversible

80 GREY

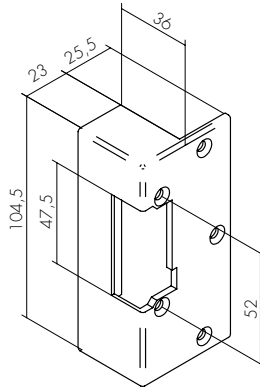

Reversible

81 GREY

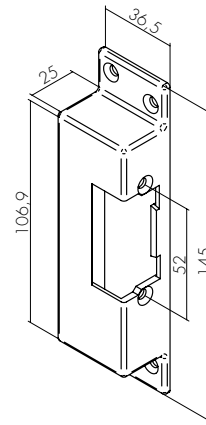

Reversible

84 GREY
CHROME
BRASS

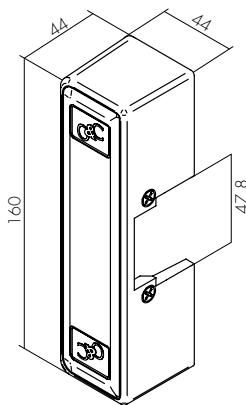

Reversible

82 BLACK

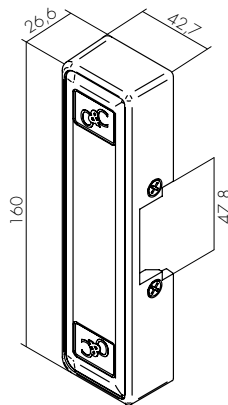

Reversible

83 BLACK + C83

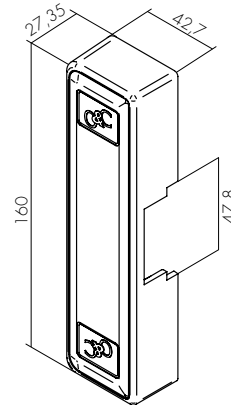

Reversible

85 BLACK + BASE + C83

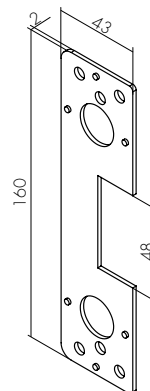
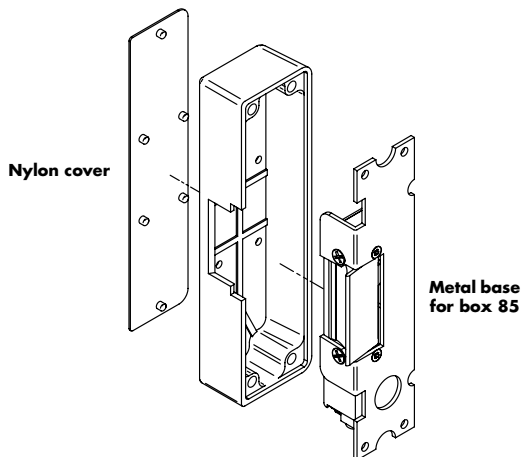

Shim kit for
box 83/85

C83

6 units
included

LONG

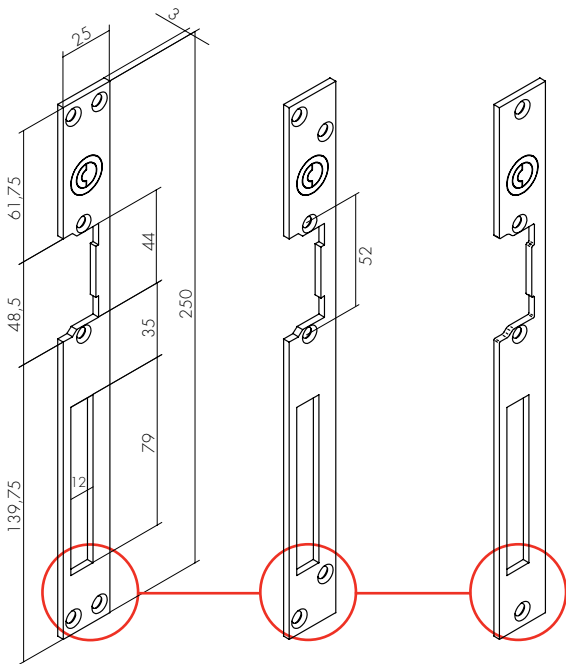

Reversible

03 GREY BROWN

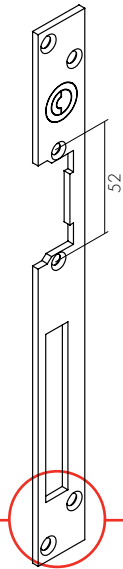

Reversible

D3 GREY BROWN

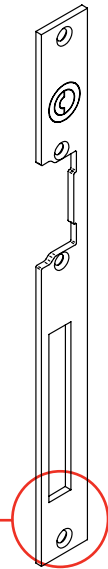

Reversible

C63 INOX 3mm

63 INOX 3mm

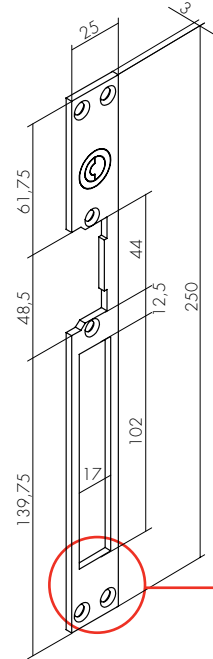

Reversible

04 GREY BROWN

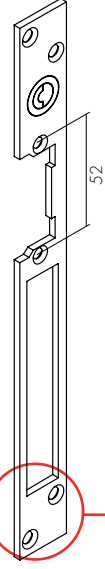

Reversible

D4 GREY BROWN

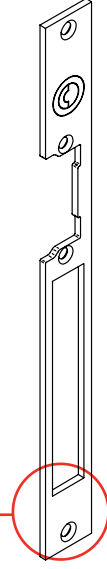

Reversible

C64 INOX 3mm

64 INOX 3mm

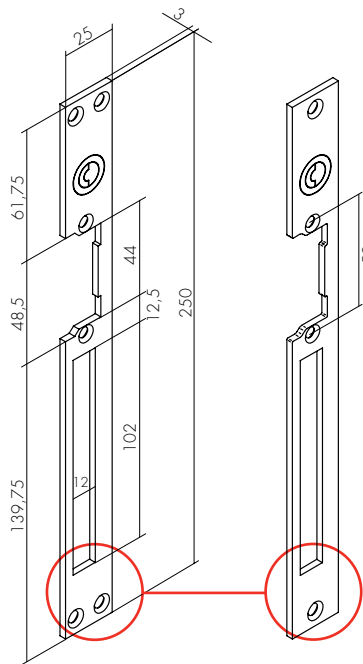

Reversible

05 GREY BROWN

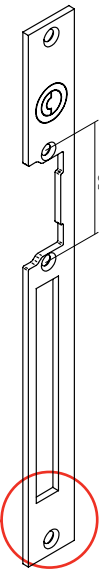

Reversible

C65 INOX 3mm

65 INOX 3mm

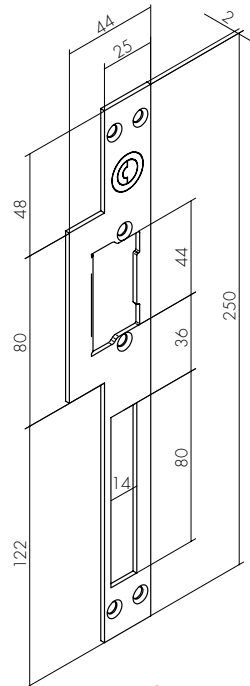

DIN Right

20 INOX 2mm

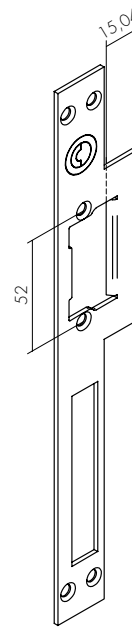

DIN Left

21 INOX 2mm

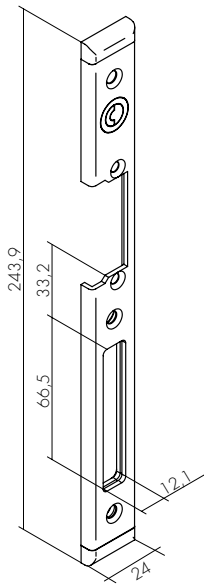

DIN Right

22 INOX
3mm

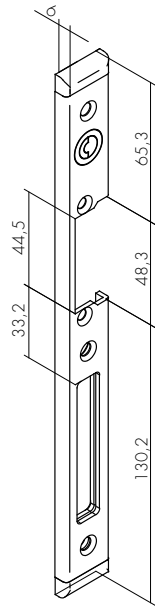

DIN Left

23 INOX
3mm

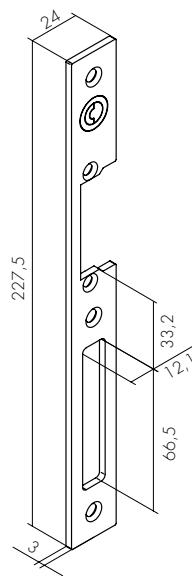

Reversible

26 INOX
3mm

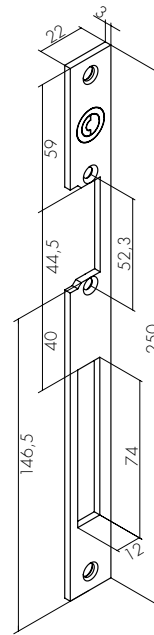

Reversible

29 INOX
3mm

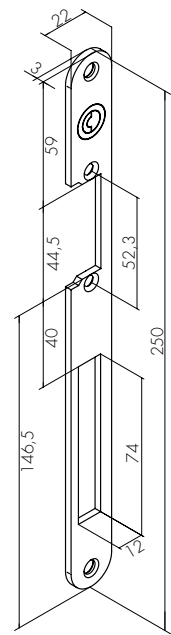

Reversible

30 INOX
3mm

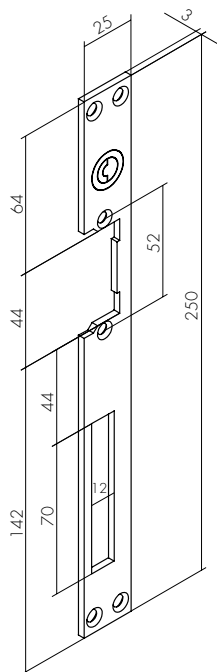

Reversible

43 INOX
3mm

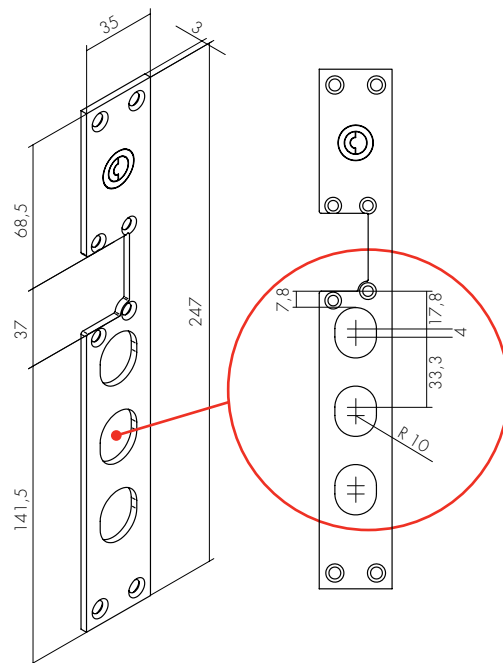

Reversible

60 INOX
3mm

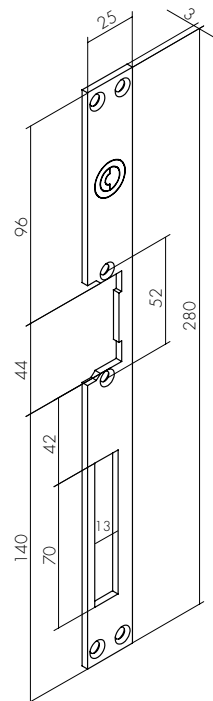

Reversible

67 INOX
3mm

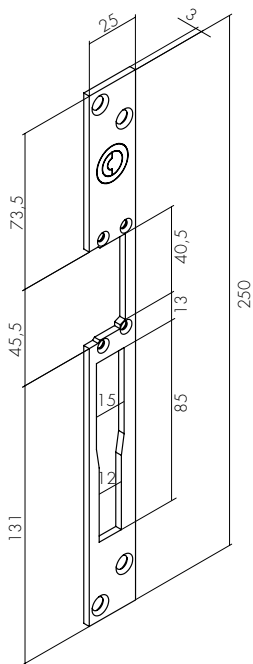

Reversible

68 INOX
3mm

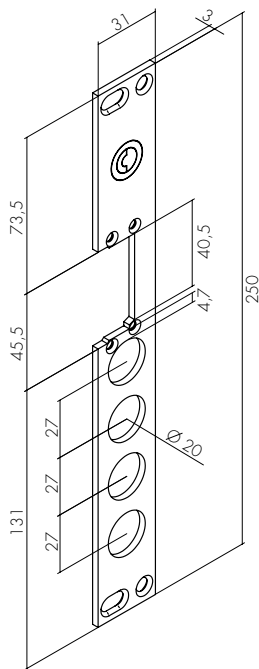

Reversible

69 INOX
3mm

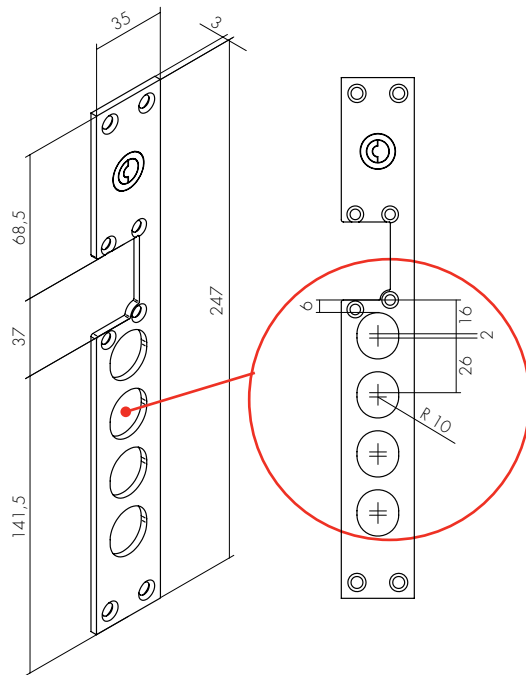

Reversible

70 INOX
3mm

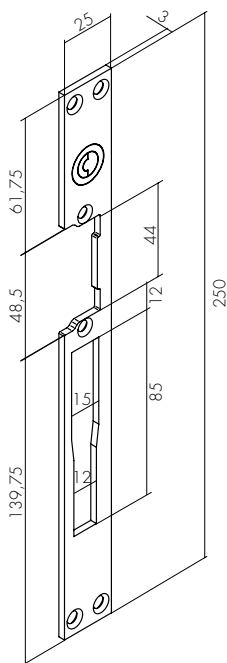

Reversible

71 INOX
3mm

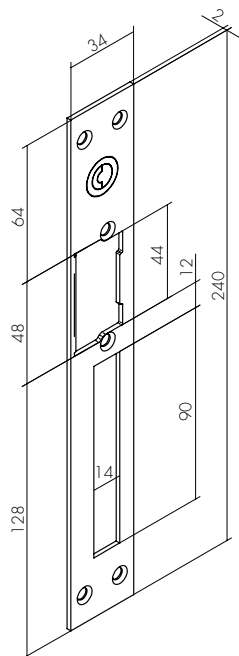

DIN Right

73 INOX
2mm

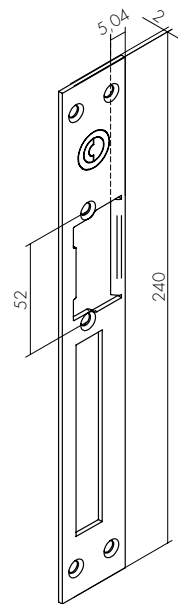

DIN Left

74 INOX
2mm

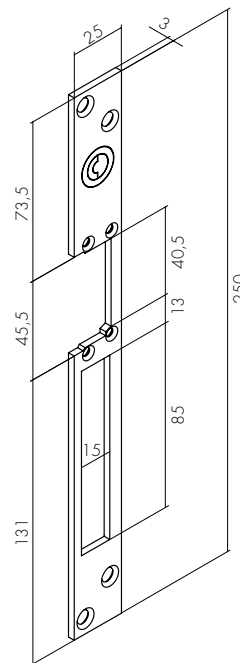

Reversible

75 INOX
3mm

ANGLED

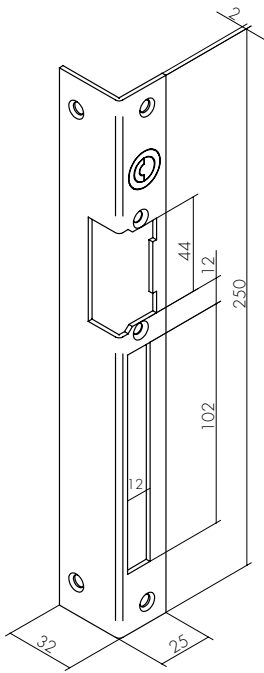

DIN Right

08 BROWN

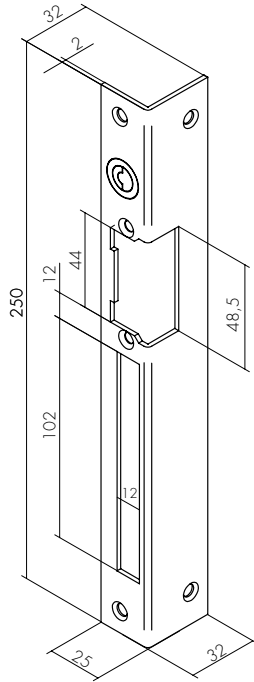

DIN Left

09 BROWN

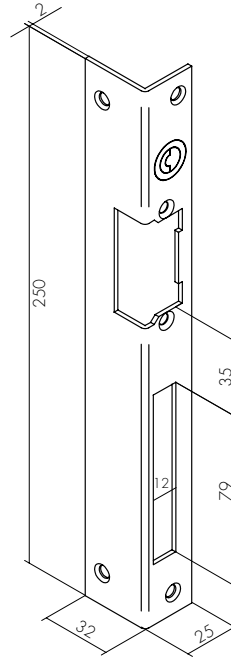

DIN Right

10 BROWN

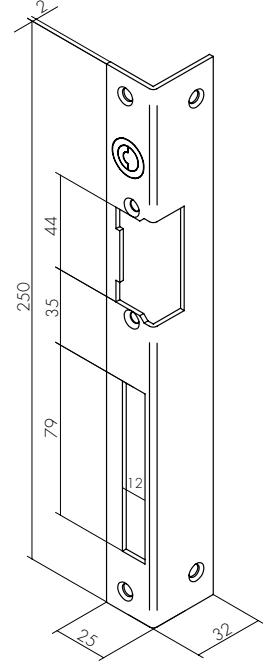

DIN Left

11 BROWN

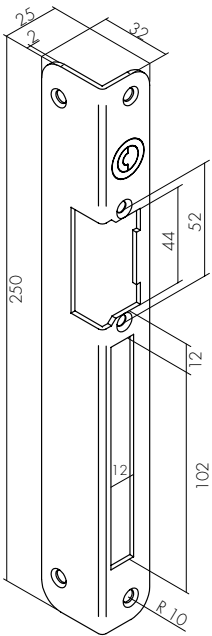

DIN Right

12 BROWN

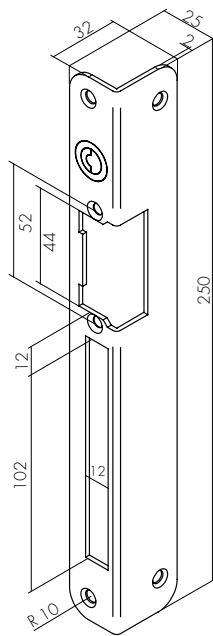

DIN Left

13 BROWN

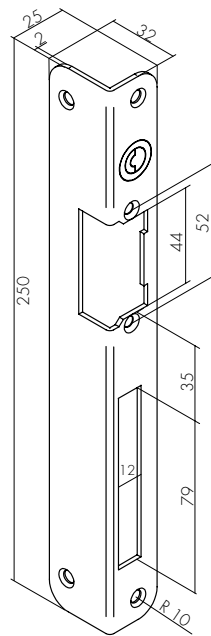

DIN Right

14 BROWN

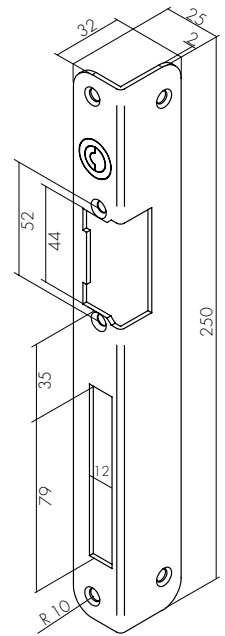

DIN Left

15 BROWN

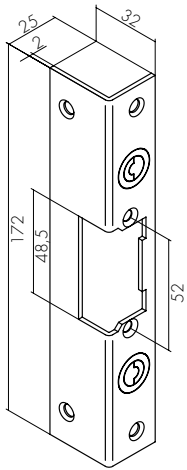

Reversible

16 BROWN

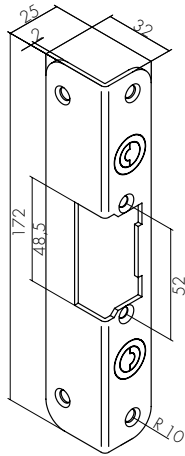

Reversible

17 BROWN

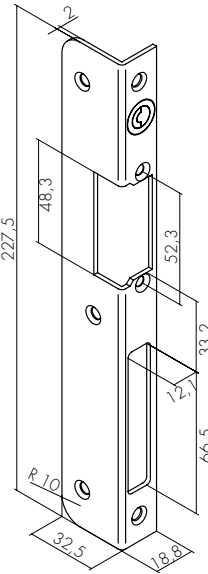

DIN Right

24 INOX
2mm

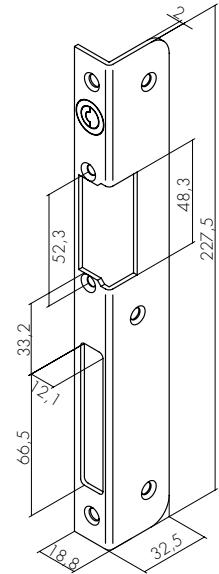

DIN Left

25 INOX
2mm

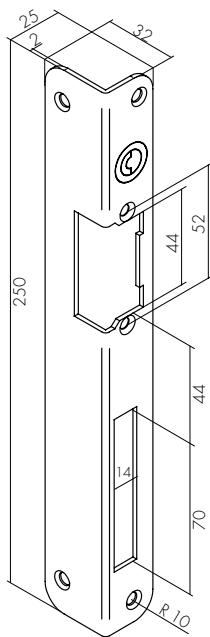

DIN Right

45 BROWN

NEW **49** INOX
2mm

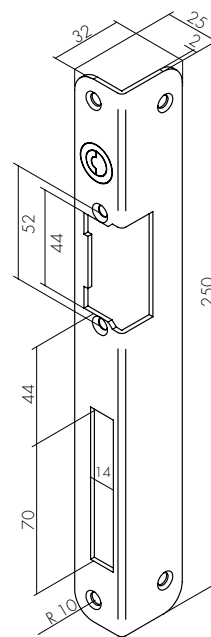

DIN Left

48 BROWN

NEW **50** INOX
2mm

ELECTROMAGNETIC LOCKS

Magnetic locks (commonly called maglocks) are a more and more popular choice among security installers for being simple to install, durable, reliable and very resistant.

A large electro-magnet is mounted on the door frame and the corresponding counterplate is mounted on the door.

When the magnet is powered and the door is closed, the counterplate is held fast to the magnet. One must unlock the maglock to both enter and leave.

In order to satisfy all customers' needs, O&C offers a wide range of electromangetic locks in different sizes, voltages, mounting and holding forces.

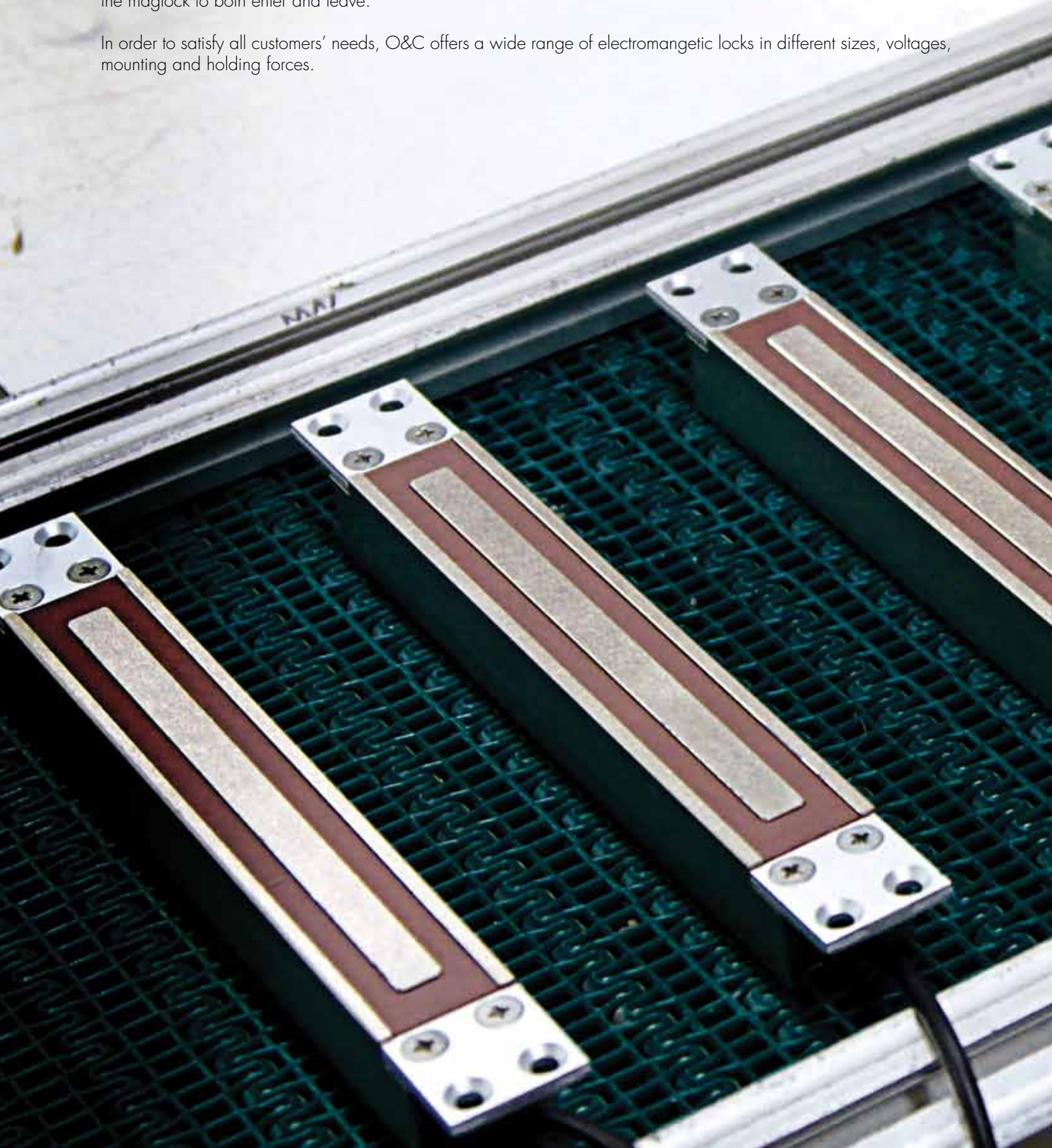

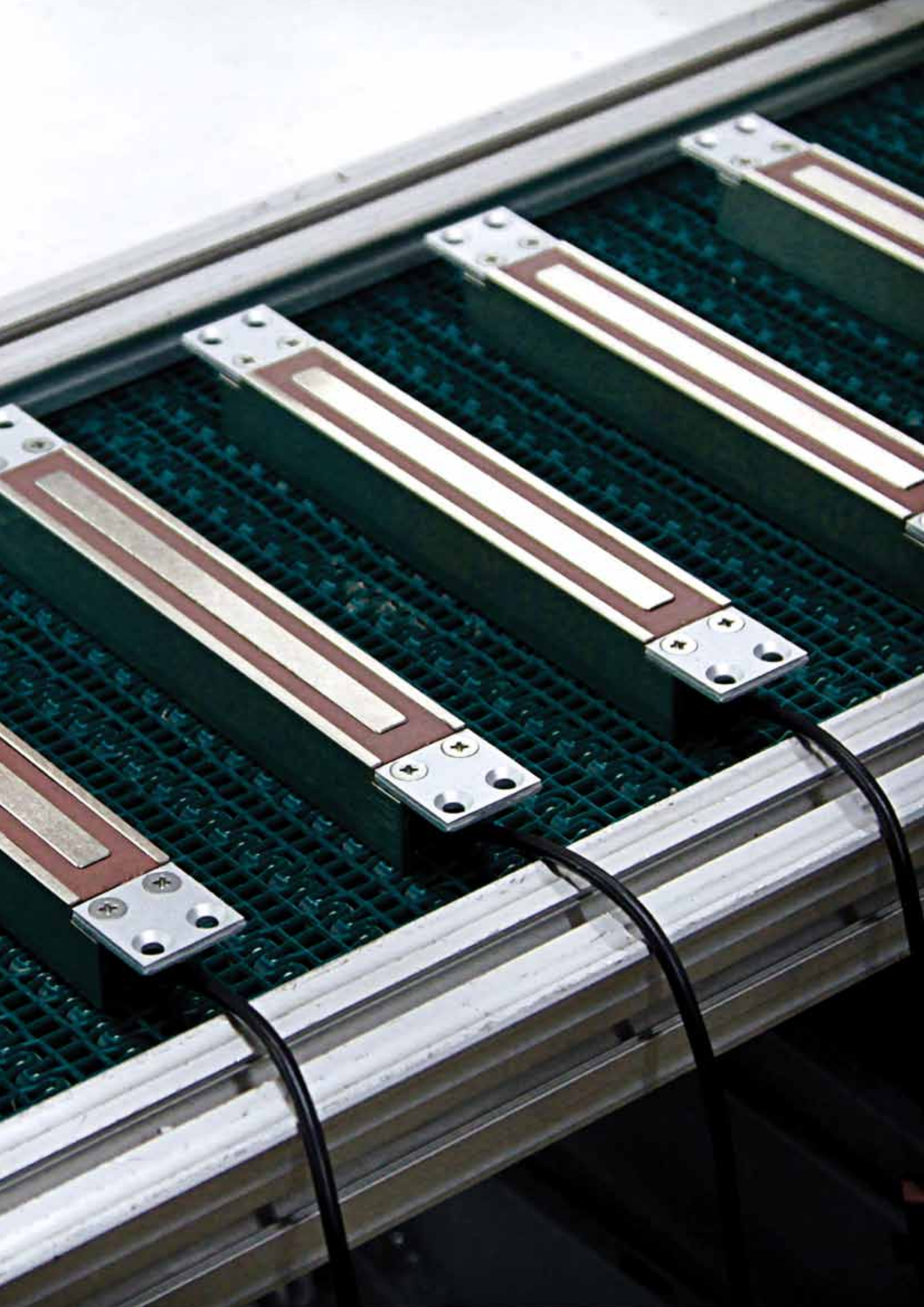

BASIC



Series MEX

Basic electromagnetic locks are the perfect locking solution for **emergency doors** and access control systems. In case of power failure, all doors will automatically open, making it safe for the occupants to exit.

They are available for mortise and rim installations with a wide range of brackets allowing an easy installation on any kind of doors and door frames.

Moreover, our vandal protection system secures the electromagnetic lock against tampering, theft or removal.

Our MEX 70 is especially designed for small applications such as closets, cabinets, showcases, drawers, lockers, etc.

Technical features

- Dual voltage 12/24V DC (automatic switch on selected models)
- Reed + LED monitoring (open/closed)
- Low power consumption
- Electronic protection
- Vandal Protection
- Timer (2 to 8 seconds)
- Guaranteed 3 years

References and features

Holding force	12 Vdc	Manual Dual voltage 12/24 Vdc	Automatic Dual voltage 12/24 Vdc	Mortise Rim	Reed + Timer	LED	L	Z	U	Mounting kit for RF fire doors (optional) MRF 810	References
							Outward opening doors	Inward opening doors	Glass doors		
700 N		•		•	•			MBAX 70	MHAX 70		MEX 70
1.800 N	•				•		MBEX 180	MBAX 180	MHAX 180		MEX 100
3.000 N	•			•							MEX 201
3.000 N			•		•		MBEX 300	MBAX 300	MHAX 300	•	MEX 400
3.000 N			•		•	•	MBEX 300	MBAX 300	MHAX 300	•	MEX 430
3.000 N x2			•		•	•	MBEX 300*	MBAX 300*	MHAX 300*	•	MEX 600
3.000 N x2			•		•	•	MBEX 300*	MBAX 300*	MHAX 300*	•	MEX 630
6.500 N			•		•		MBEX 600	MBAX 600			MEX 700
6.500 N			•		•	•	MBEX 600	MBAX 600			MEX 730
6.500 N			•	•	•						MEX 900

* Remember to order one unit for each electromagnetic lock

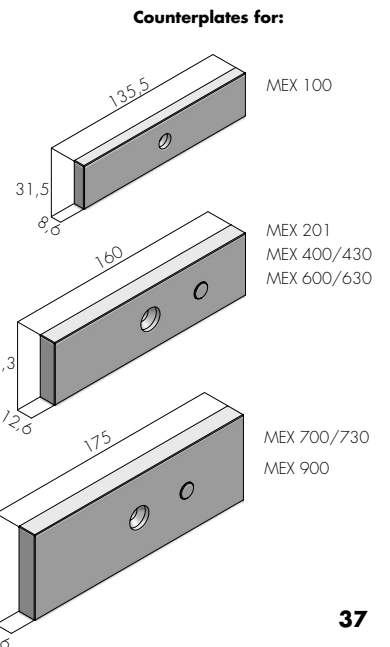
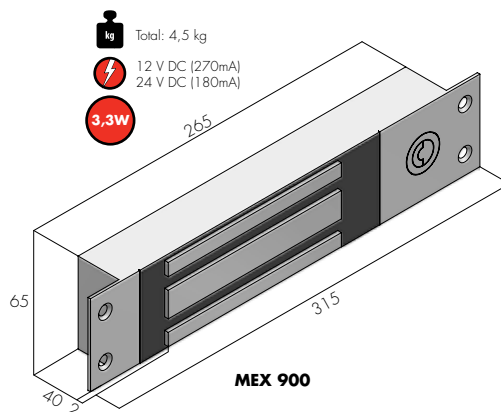
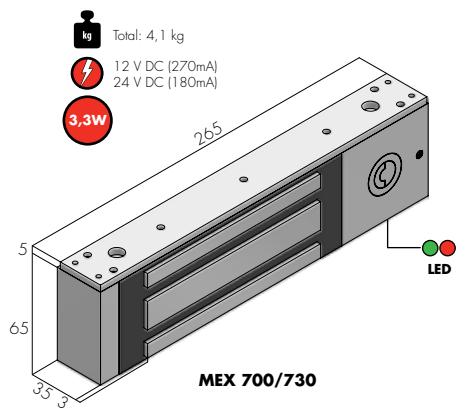
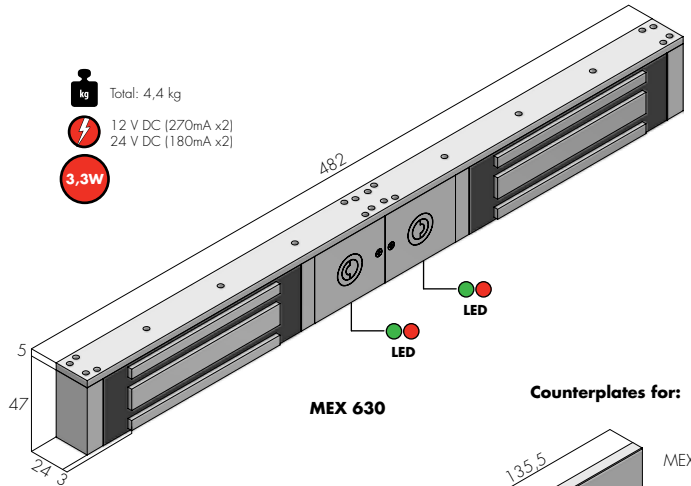
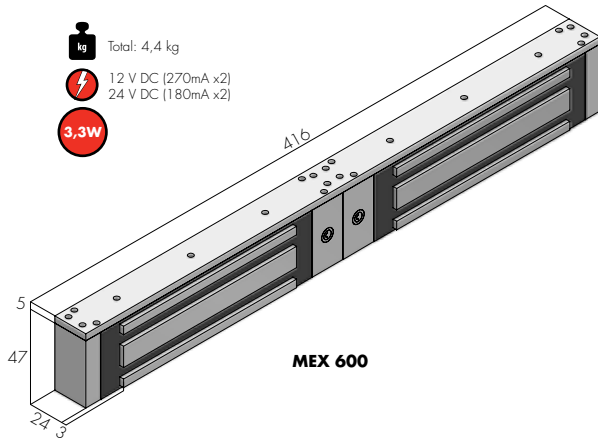
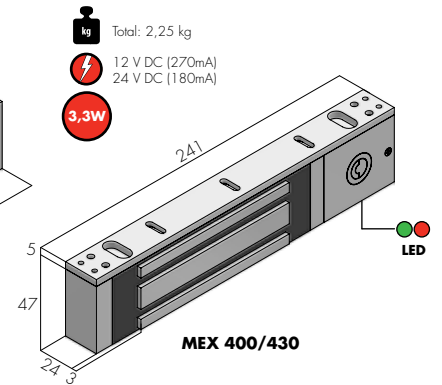
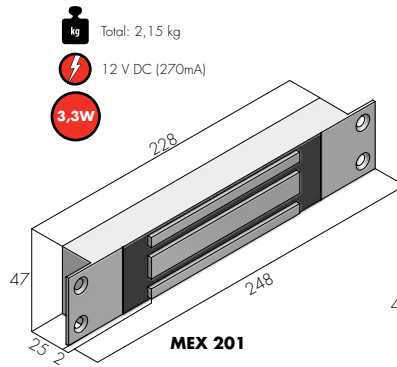
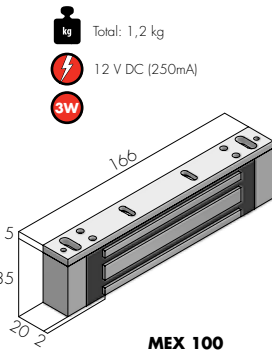
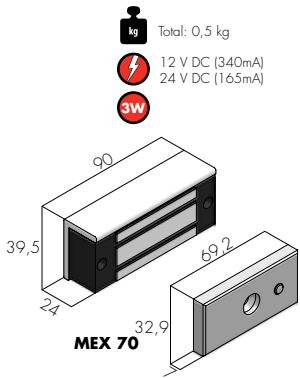

BRACKETS FOR BASIC ELECTROMAGNETIC LOCKS

L For outward opening doors.

MBEX 180
For MEX 100

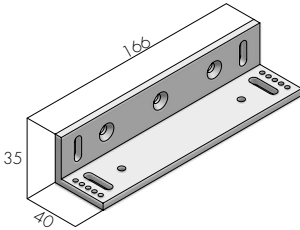

MBEX 300
For MEX 400/430/600*/630*

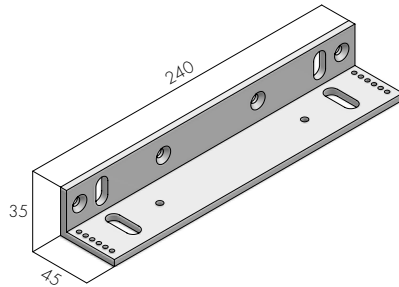

MBEX 600
For MEX 700/730

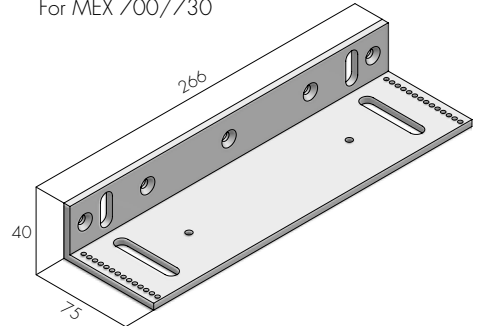

Z For inward opening doors.

MBAX 70
For MEX 70

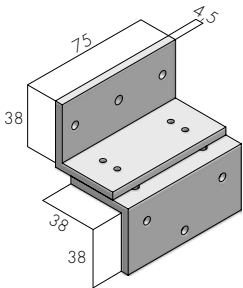

MBAX 180 (3 units)
For MEX 100

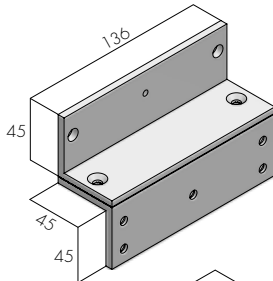

MBAX 300 (3 units)
For MEX 400/430/600*/630*

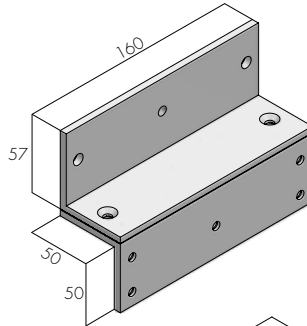

MBAX 600 (3 units)
For MEX 700/730

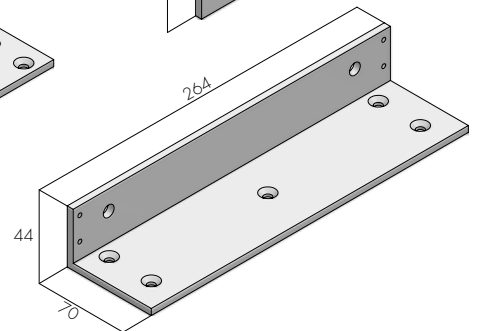
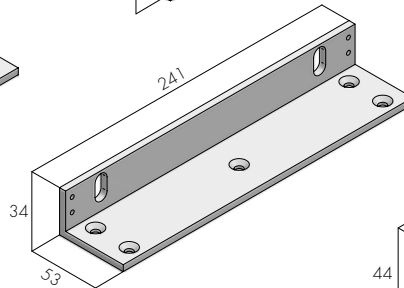
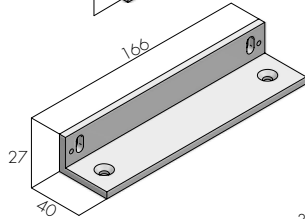
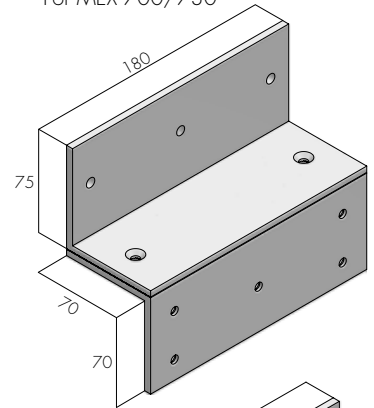

U For glass doors.

MHAX 70
For MEX 70

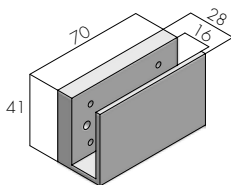

MHAX 180
For MEX 100

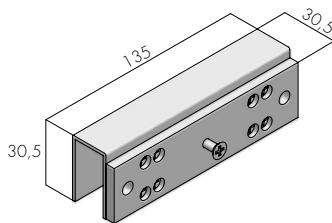

Max. glass thickness: 12 mm

MHAX 300
For MEX 400/430/600*/630*

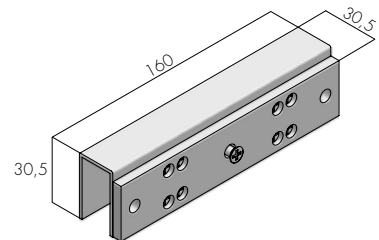

Max. glass thickness: 16 mm

Mounting kit for fire doors

MRF 810
For MEX 400/430/600*/630*

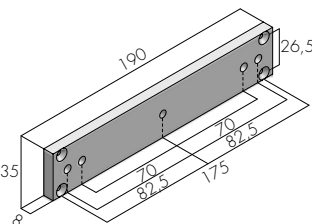

* Remember to order one unit for each electromagnetic lock!

MOST COMMON INSTALLATIONS

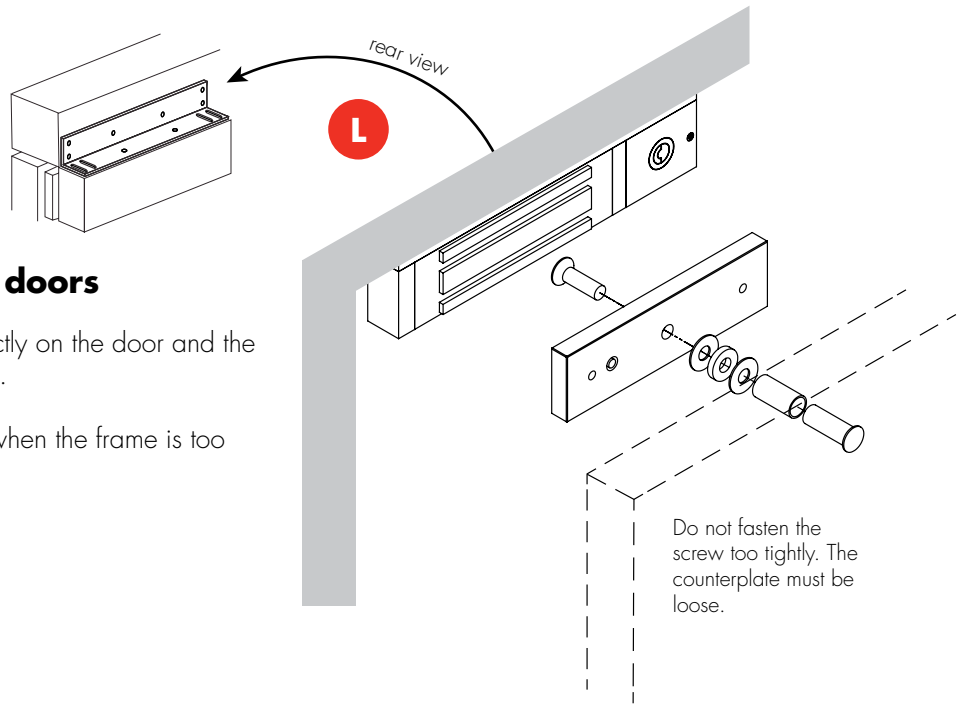

For outward opening doors

The counterplate is installed directly on the door and the magnetic lock beneath the frame.

An "L" bracket may be needed when the frame is too narrow.

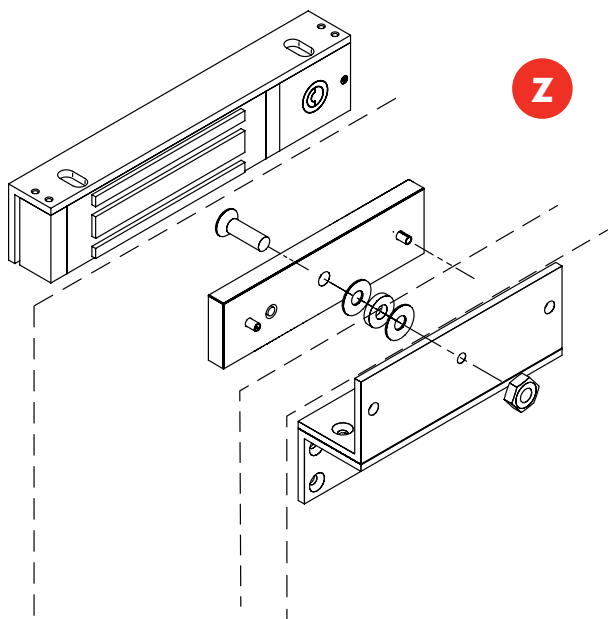

For inward opening doors

The counterplate is installed on a "Z" bracket mounted on the interior door leaf directly to the door.

The electromagnetic lock has to be installed on the frame, on the opposite side of the hinges.

For glass doors

The counterplate is installed directly on the door leaf. The electromagnetic lock has to be installed under the frame.

An "L" bracket may be needed when the frame is too narrow.

Please remember that the distance between the glass door and the frame needs to be at least 3 mm.

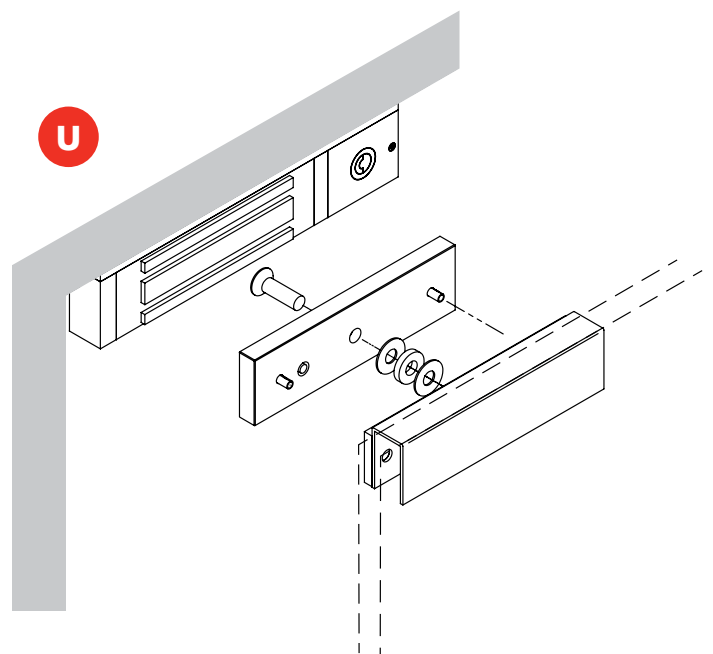

MINI



Series ME

The mini electromagnetic locks can be integrated into the most sophisticated interior decorations, to satisfy our most creative customers.

Being **the thinnest on the market** (only 30 mm), they can fit most door frames, offering at the same time a high holding force and a very high sensitivity. Any attempt of manipulation will immediately activate the in built monitoring.

In order to certify our quality, O&C tests every mini electromagnetic lock individually and attaches the test results to the packaging.

Also available in waterproof, the ideal solution for exterior doors and gates.

Technical features

- Dual voltage 12/24V DC
- Reed monitoring (open/closed)
- Low power consumption
- Electronic protection
- Guaranteed 3 years

Certification ME 500/510

* IP65 (protected against dust and water)

References and features

MBE 800 included with ME 400/410/420

MBE 805 included with ME 600/610/620

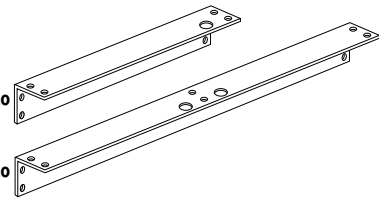

Holding force	Dual voltage 12/24 Vdc	Mortise	Rim	LED	Monitoring	L Outward opening doors	Z Inward opening doors	U Glass doors	Bracket cover for (optional):		Mounting kit for RF fire doors (optional) MRF 810	Mounting kit for sliding doors (optional) MSA 803	References
									L FSC 821	Z FSC 822			
2.800 N	●	●										●	ME 200
2.800 N	●	●										●	ME 201
2.800 N	●	●			●							●	ME 210
2.800 N	●	●			●							●	ME 211
2.800 N	●	●	●			MBE 806	MBA 801/802	MHA 804	●	●	●		ME 400
2.800 N	●	●	●		●	MBE 806	MBA 801/802	MHA 804	●	●	●		ME 410
2.800 N	●	●	●	●	●	MBE 806	MBA 801/802	MHA 804	●	●	●		ME 420
2.500 N	●	●	●			MBA 806/808	MBA 801/802						ME 500
2.500 N	●	●	●		●	MBA 806/808	MBA 801/802						ME 510
2.800 N x 2	●	●	●			MBE 807	MBA 801/802*	MHA 804*	●	●	●		ME 600
2.800 N x 2	●	●	●		●	MBE 807	MBA 801/802*	MHA 804*	●	●	●		ME 610
2.800 N x 2	●	●	●	●	●	MBE 807	MBA 801/802*	MHA 804*	●	●	●		ME 620

IP 65
IP 65

* Remember to order one unit for each electromagnetic lock!

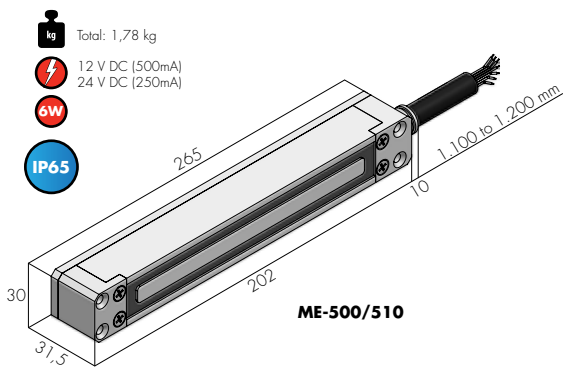
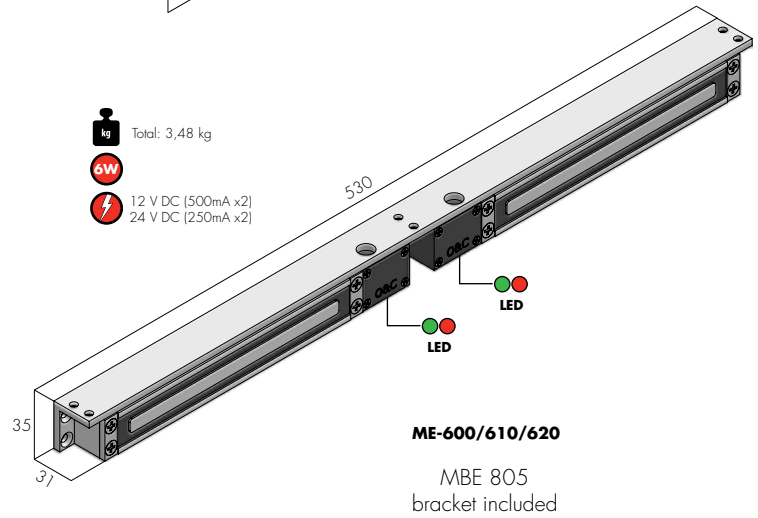
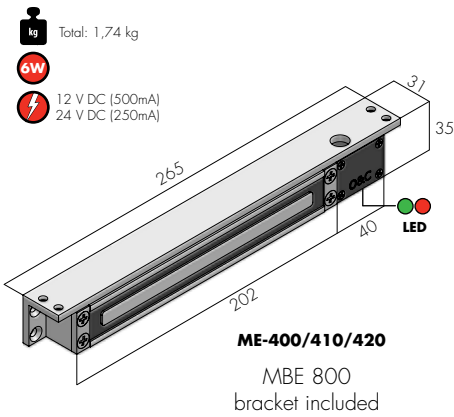
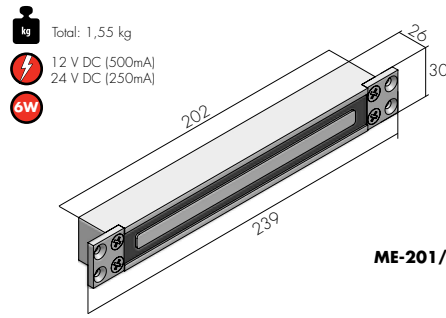
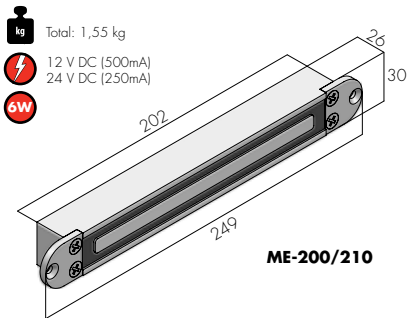

WATERPROOF

Counterplate mounting kit included

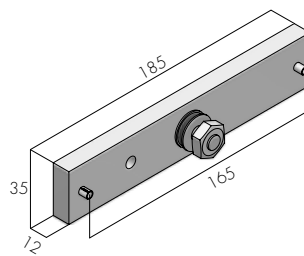

"Z" installation

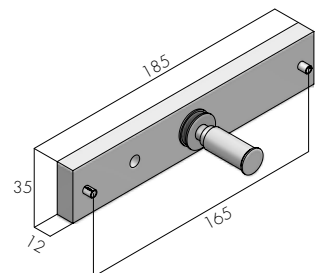

"L" installation

BRACKETS FOR MINI ELECTROMAGNETIC LOCKS

L For outward opening doors.

MBE 806 (adjustable)
For ME 400/410/420/500/510

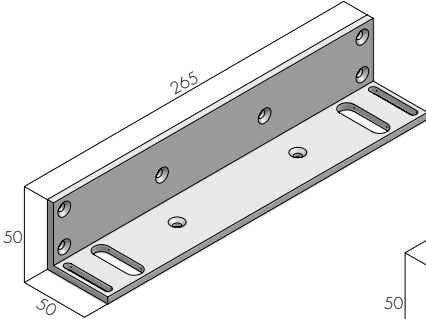

MBE 807 (adjustable)
For ME 600*/610*/620*

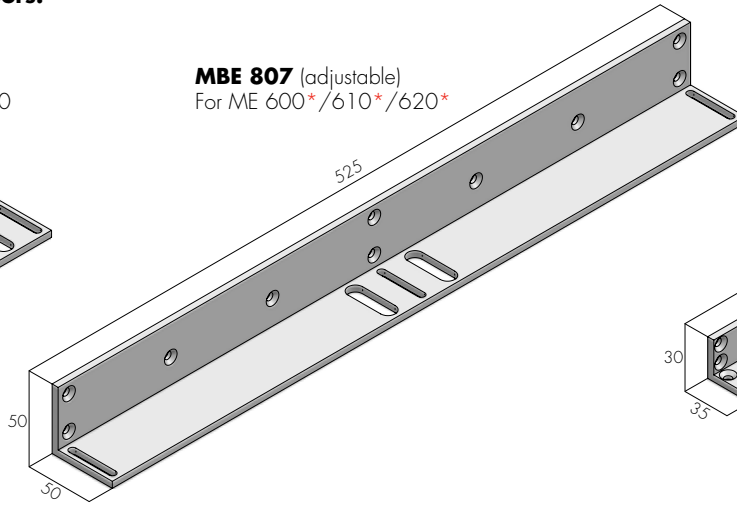

MBE 808
For ME 500/510

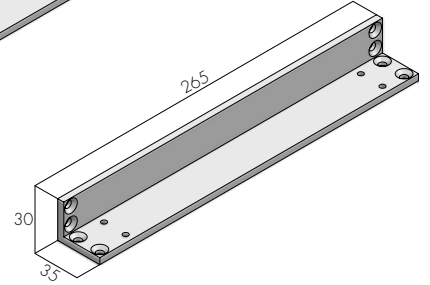

Z For inward opening doors.

MBA 801/802
For ME 400/410/420/500/510/600*/610*/620*

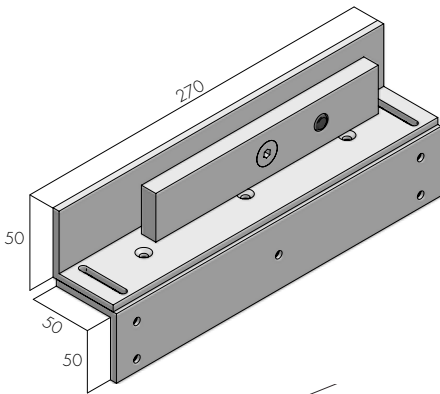

U For glass doors.

MHA 804
For ME 400/410/420/600*/610*/620*

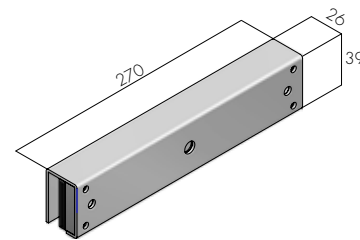

Glass thickness: 8 to 14 mm

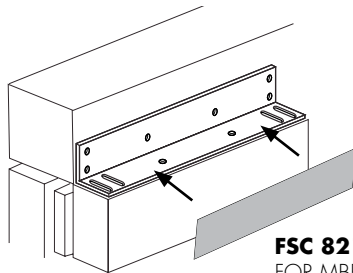

FSC 821
FOR MBE 806/807

Bracket cover

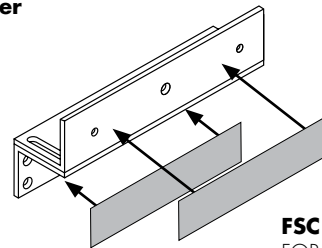

FSC 822
FOR MBA 801/802

Mounting kit for fire door

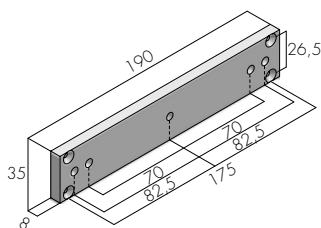

MRF 810
FOR ME 400/410/420/600*/610*/620*

Mounting kit for sliding doors

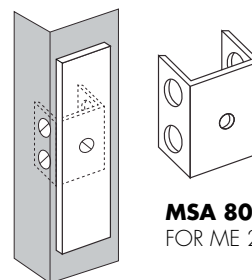

MSA 803
FOR ME 200/201/210/211

* Remember to order one unit for each electromagnetic lock!

MOST COMMON INSTALLATIONS

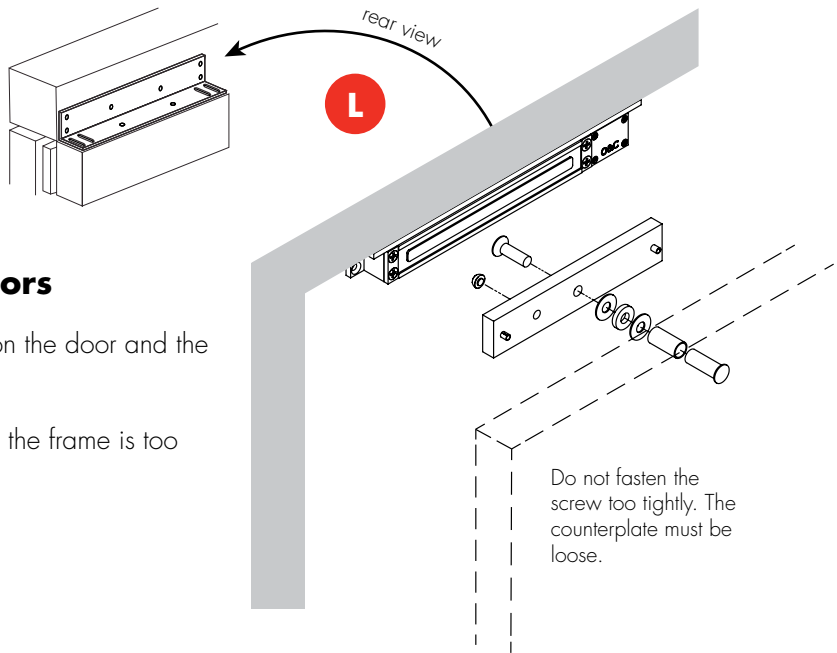

For outward opening doors

The counterplate is installed directly on the door and the magnetic lock beneath the frame.

An "L" bracket may be needed when the frame is too narrow.

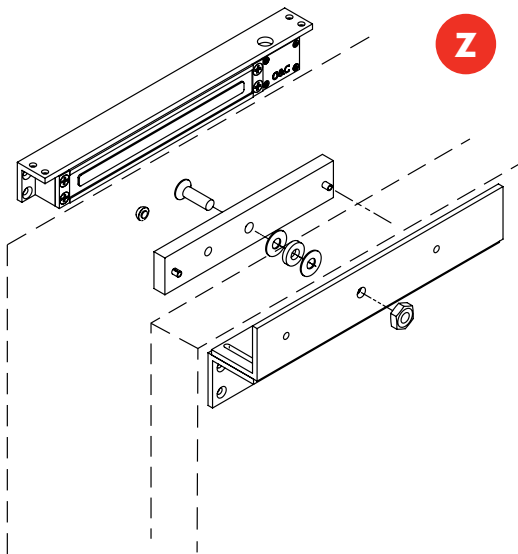

For inward opening doors

The counterplate is installed on a "Z" bracket mounted on the interior door leaf directly to the door.

The electromagnetic lock has to be installed on the frame, on the opposite side of the hinges.

For glass doors

The counterplate is installed directly on the door leaf. The electromagnetic lock has to be installed under the frame.

An "L" bracket may be needed when the frame is too narrow.

Please remember that the distance between the glass door and the frame needs to be at least 3 mm.

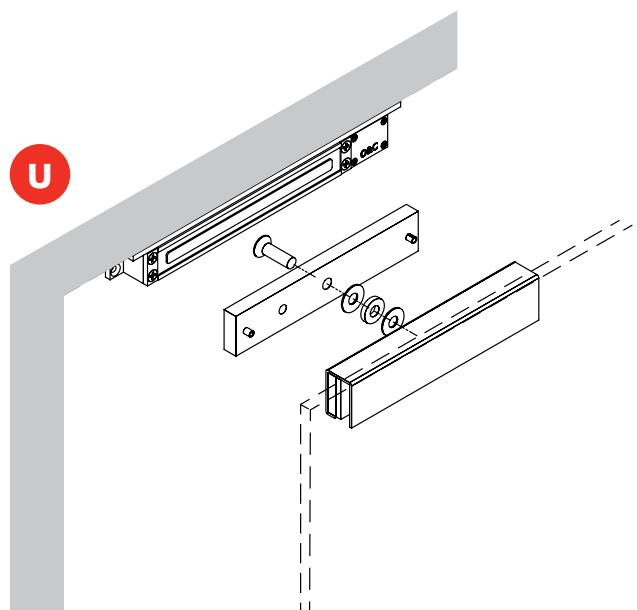

DOOR HOLDER



Series DH

Designed to be used on self-closing swinging doors to automatically isolate an area when activated by fire alarm, smoke detection or sprinkler systems.

Typical installations are: **hospitals, schools, nursing homes, public buildings** (closes all exit doors at once by push button control) and offices (instant privacy by pushing a button on your desk).

Magnetic door holders can also be operated by manual release, wherever the instant closing of doors is needed for safety or convenience.

Wall or floor supports available.

Technical features

- 600 N holding force
- Jumper for voltage switch (on DHB)
- Ejector pin to overcome residual magnetism
- Manual release button
- Low power consumption

Certifications

- Complies with UNE-EN 1155:2003

3	5	3	0	1	3
		4			

References and features

Voltage 24 Vdc	Manual Dual voltage 12/24 Vdc	HOLDING FORCE	Timer 3 sec.	Manual release button	Block	References
•		600 N			50 mm	DHI - Industrial door holder
•		600 N			50 mm	DHS - Basic door holder
	•	600 N		•	50 mm	DHB - Dual voltage door holder
•		600 N	•	•	50 mm	DHT - Door holder with timer
•		300 N/600 N		•	50 mm	DHD - Door holder with power-regulation
						DFS 160 - Door holder support
						DFS 300 - Door holder support
						PDH - Manual Release Button
						ADH - Counterplate for DHB / DHT / DHD
						AHI - Counterplate for DHI
						AHS - Counterplate for DHS

Accessories & Spares

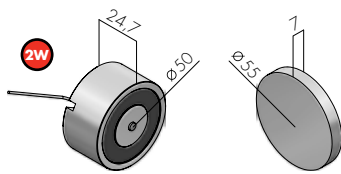

DHI
24 V DC (85mA)

AHI
(included)

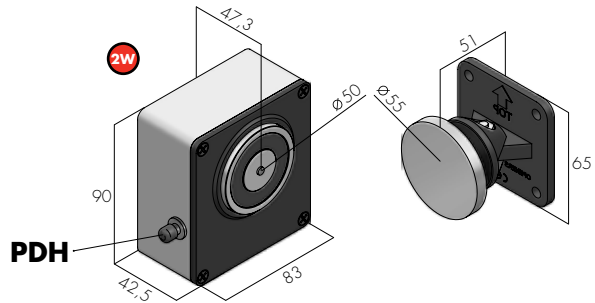

PDH

DHB
12 V DC (170mA)
24 V DC (85mA)

ADH
(included)

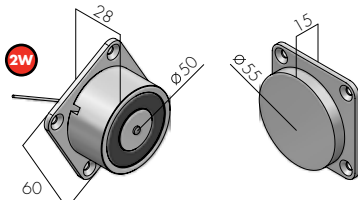

DHS
24 V DC (85mA)

AHS
(included)

DHT
24 V DC (85mA)

DHD
24 V DC (85mA)

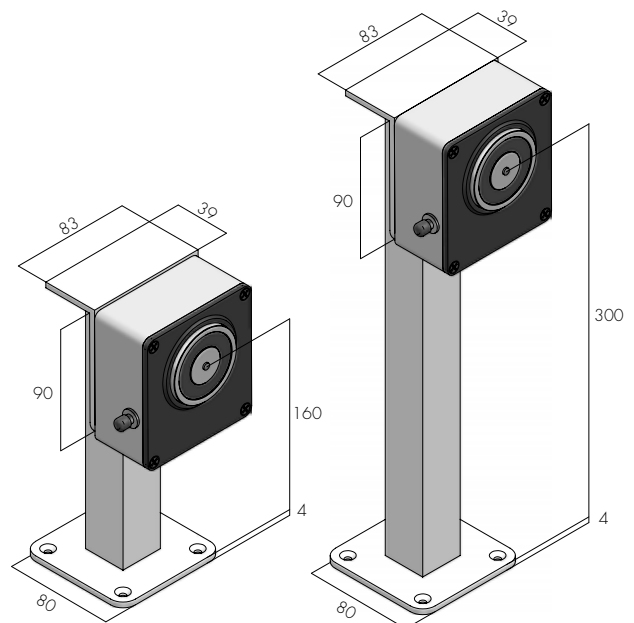
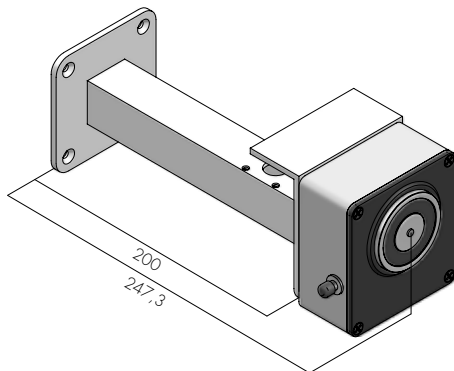

DFS 160

DFS 300

SHEARLOCK



Series SH

Shearlocks are the ideal solution for **glass, swing and sliding doors**. They combine magnetic and mechanical force generating a massive holding force. Shearlocks can be timed and connected to fire detectors, alarms, access control systems, emergency exit buttons, etc. If a locking defect happens after 5 attempts, the shearlock emits a warning sound until the system is reset.

Example of use:

A thief tries to escape through an emergency door where a panic bar and a shearlock are installed. When the thief pushes the panic bar, the door will still be locked by the shearlock for the programmed time, and a warning signal will be sent to the store's control center. If the system is equipped with an acoustic alarm, it will be ringing for the time the shearlock is programmed to, forcing the thief to drop the goods.

Technical features

- 15.000 N holding force
- Electronic protection
- Timer: adjustable from 0 to 25 seconds for both locking (T1) and unlocking (T2)
- Maximum distance between parts: 3 mm
Minimum distance between glasses: 6,5 mm
- 3 colours LED indicator (opened/closed/malfunction)
- Power from 10 to 36V DC (automatic switch)
- Operating temperature: from -5 to +60 °C plus 8/10 °C on DC current
- Consumption at 12V DC: 2A (start up) then 0,5A (operating)
- Auxiliary relay: max. 1A at 24V DC
- Guaranteed 3 years

References and features

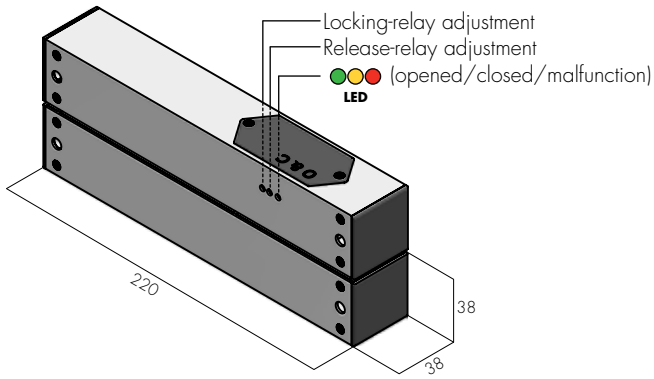

SHEARLOCK SH 100
(rim installation)

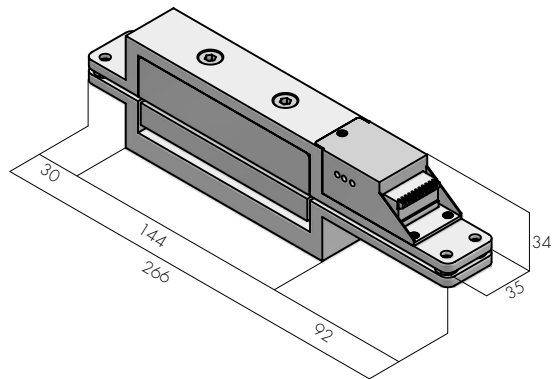

SHEARLOCK SH 200
(mortise installation)

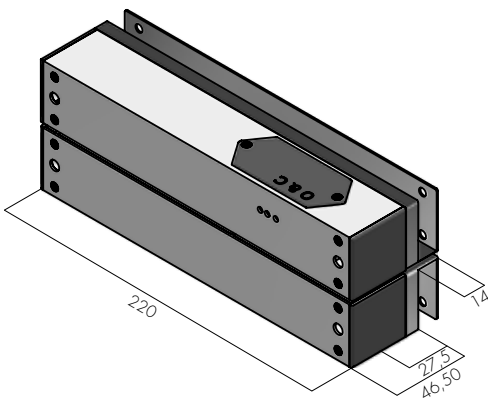

SHEARLOCK SH 300
(glass/glass installation)

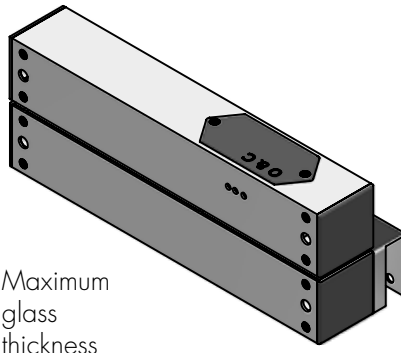

SHEARLOCK SH 400
(rim/glass installation)

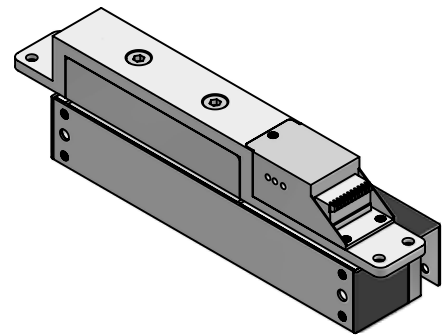

SHEARLOCK SH 500
(mortise/glass installation)

Installation example

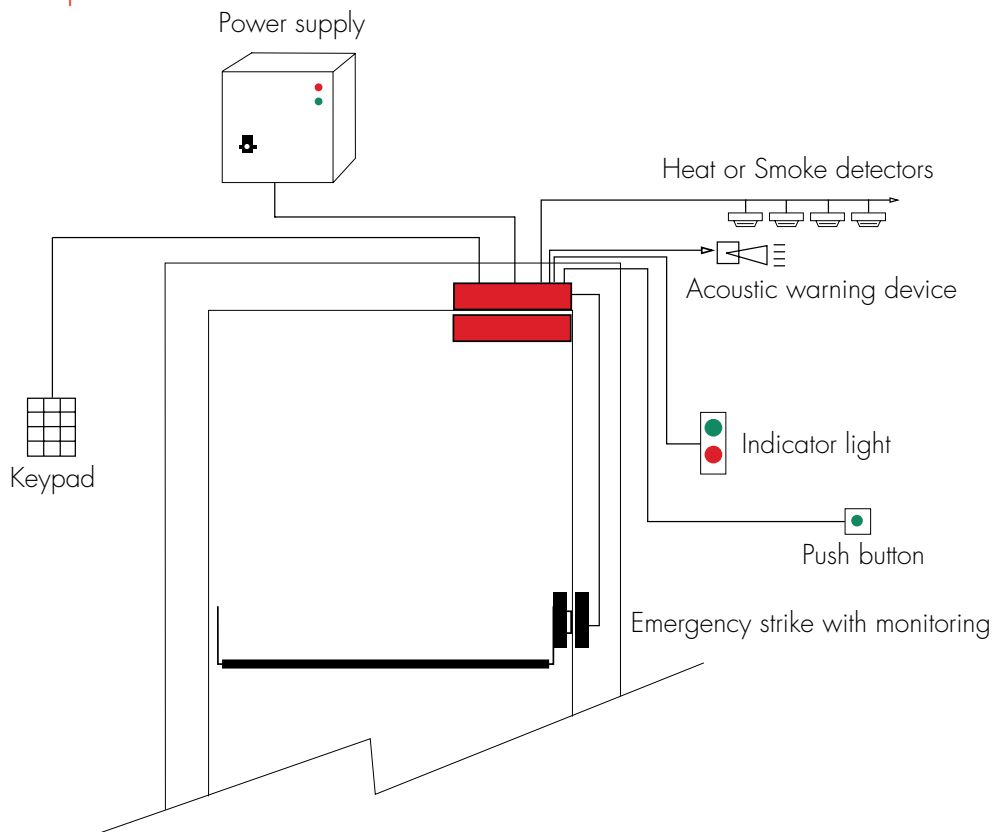

ELECTRIC LOCKS

A close-up photograph of a hand turning a brass handle on a green door. The door has a silver strike plate with several screws. A set of keys is hanging from the lock cylinder. The background is blurred, showing a wooden door frame.

A lock is a mechanical or electronic fastening device that is released by a physical object (such as a key, keycard, fingerprint, RFID card, or security token) or secret information (such as a keycode or password), or combination of both.

An electric lock is a locking device which operates by means of electric current. Electric locks are usually connected to an access control system. The advantages of an electric lock connected to an access control system include: key control, where keys can be added and removed without re-keying the lock cylinder; fine access control, where time and place are factors; and transaction logging, where activity is recorded.

MINI ELECTRIC BOLT

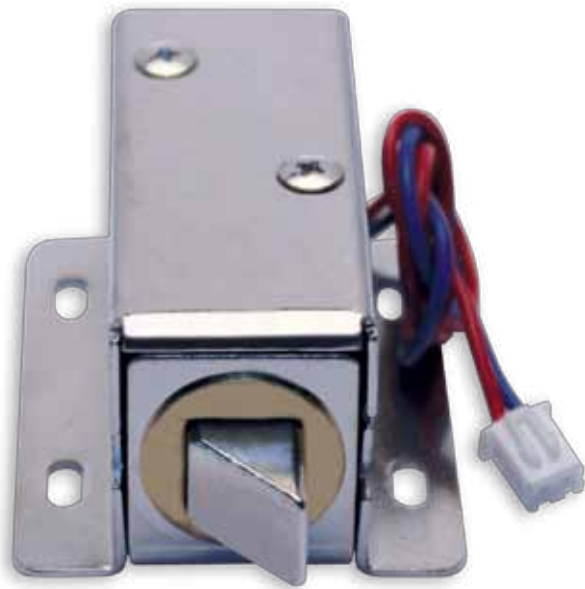



Series PGX

This small fail-secure lock has been especially designed for applications such as **lockers, closets, showcases, drawers**, etc.

It can be installed either rim or mortise and its latch is 360° reversible.

Operating temperature from -20 °C to +40 °C.

3 years guarantee.

-  0,130 kg
-  12 V DC (650mA)
-  7,8W

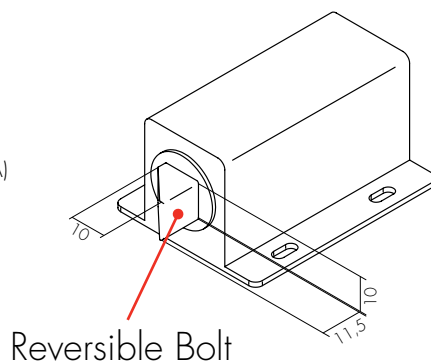

PGX 03

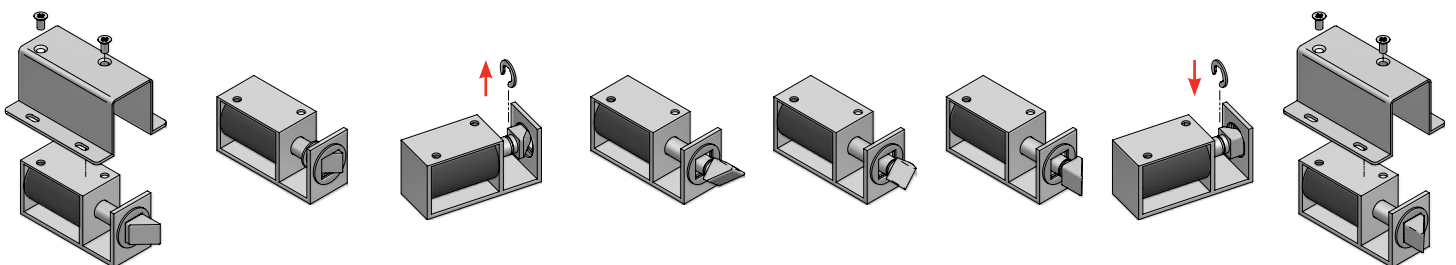
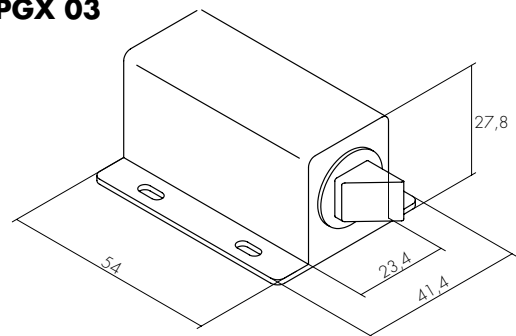

RIMTOPLOCK



Series CE

Rimtoplocks are **reversible rim-mounted electric locks with a motorized bolt**. When the magnetic sensor confirms the door is aligned with the frame, the 25mm bolt will automatically lock the door. After the scheduled releasing time, the Rimtoplock will lock the door back. The distance between the lock and the counterplate should be 5mm. An acoustic warning will beep if the door is not properly closed.

Access from the outside will be granted through access control or keys (3 keys included), while from the inside one can choose among knob, switch, push button and keys. It is usually installed on interior wooden or aluminum doors, but a protecting visor is available for outdoor installations.

	Voltage 12V DC	Timer 2 to 8s	Magnetic sensor	Acoustic alarm	Consumption 500mA	Keys	Push button	Switch button	Knob	References
RIMTOPLOCK	•	•	•	•	•		•		•	CE 104
	•	•	•	•	•			•	•	CE 105
	•	•	•	•	•				•	CE 106
	•	•	•	•	•	•				CE 109
									Protecting visor	VCX 100

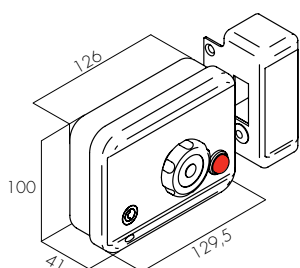

CE - 104
WITH PUSH-BUTTON
(temporary unlocking)

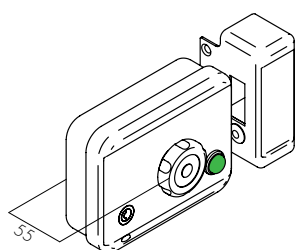

CE - 105
WITH SWITCH-BUTTON
(permanent unlocking)

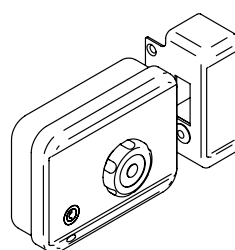

CE - 106
WITH KNOB

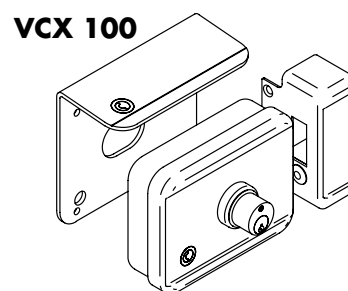

VCX 100
CE - 109
WITH KEYS

BASIC ELECTRIC BOLT

Series OC

This **compact easy-to-install lock** (only 24 mm thick) secures the door through a 16 mm steel bolt which is activated by a solenoid.

It operates on 12V DC and uses 300mA during start-up and 120mA in stand-by. The gap between the lock body and the plate should be less than 8 mm.

A LED indicator will show the status of lock (opened/closed). The auto-lock function can be set after 0 to 9 seconds through the inbuilt timer.

	fail-secure	fail-safe	Mortise	Rim	Glass	Timer	Round bolt	References
BASIC ELECTRIC BOLT	•		•			•	•	OC 860
		•	•			•	•	OC 870
		•		•		•	•	OC 880
		•			•	•	•	OC 890

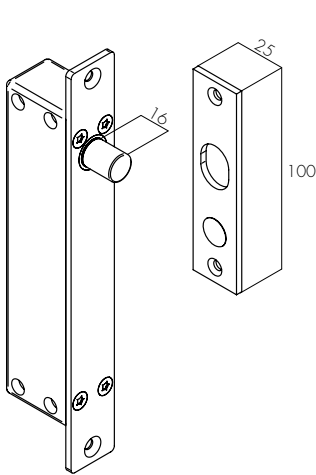

**OC 860
Mortise**

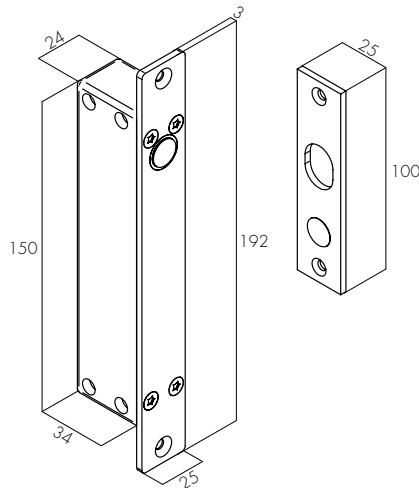

**OC 870
Mortise**

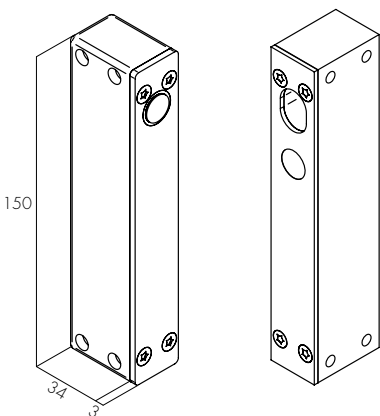

**OC 880
Rim**

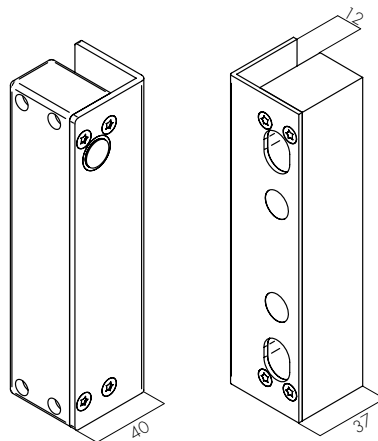

**OC 890
For glass doors**

Maximum glass thickness: 12 mm



ACCESSORIES

Along with locks and strikes, other pieces of equipment are necessary to complete an access control system.

OPENERS & CLOSERS carries a complete line of access control accessories, including indicator lights, contacts, door loops, keypads, push-buttons and more.



ELECTRIC CONTACTS

Series DDC

Our high-quality door contacts are designed to provide **hidden electric connection between the lock and the power supply** (basically from the door to the door frame). They need to be mortise mounted where the hinges are.

The DDC 002 contact is suggested for simple installations where the connection is intermittent. Its two brass poles are nickel-plated and the plastic parts can be either black or white.

The DDC 004 contact is ideal for permanent connection and on sliding doors. Its four brass poles are silver-plated and the plastic parts are white.



Electrical features and dimensions

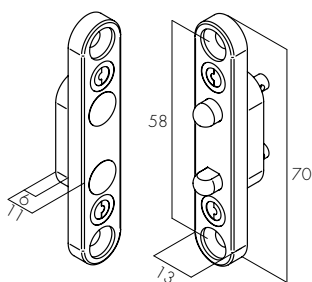

DDC 002

- ⚡ Max. switching voltage 24V AC/DC
- Max. switching current 1,5 A

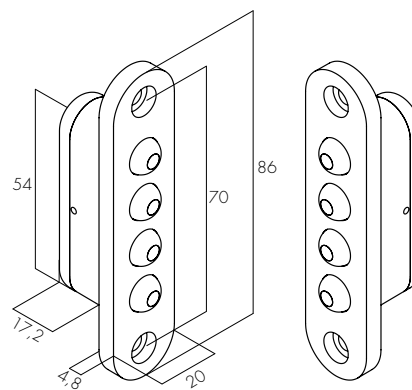

DDC 004

- ⚡ Max. switching voltage 24V AC/DC
- Max. switching current 0,5 A

INDICATOR LIGHTS

Series TL

OPENERS & CLOSERS' indicator lights combine design, robustness and functionality, making them ideal for all **hearing- or visually-impaired-friendly installations.**

The internal jumper allows the audible warning and the LEDs to operate intermittently. They operate on 10 to 24V AC/DC and their connection is not polarized. They can be either mortised or rim mounted, by simply adding the included plastic box.

Guaranteed 3 years.



2 Bulbs	Push button	Acoustic warning	mortise installation	rim installation	References
Red and Green			•	•	TLX 001
Red and Green	•		•	•	TLP 002
Red and Green		•	•	•	TLB 001
Red and Green	•	•	•	•	TLB 002

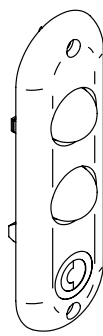

mortise

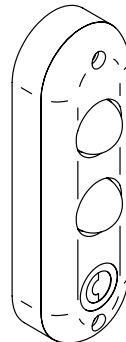

rim

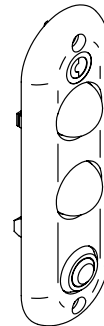

mortise

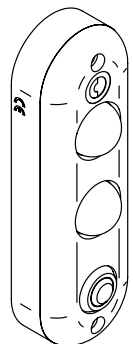

rim

TLX 001

TLP 002

with push button (NO)

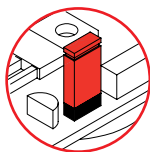

with jumper

The audible warning device and the LED light remains in steady mode.

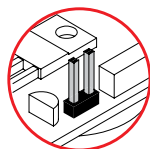

without jumper

The audible warning device and the LED light remains in flashing mode.

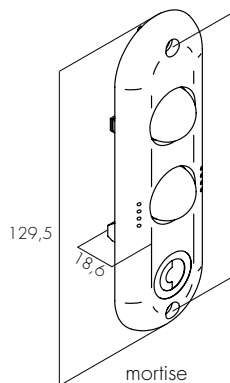

mortise

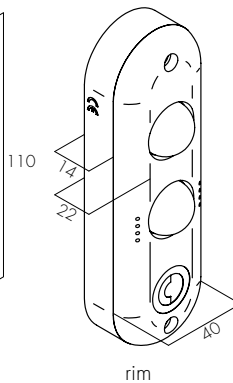

rim

TLB 001

with acoustic warning

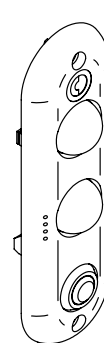

mortise

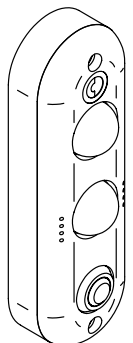

rim

TLB 002

with push button (NO) and acoustic warning

DOOR LOOPS

Series FX

Door loops are required when installing an electric lock on the door. They secure the **connection of power from the wall to the door** (on the hinges side).

Our door loops offer a high quality steel finish and are available in several lengths and mountings.

	External diameter	Internal diameter	Finish color	Flex tube lenght	Total lenght	References
Mortise	14,5 mm	10,5 mm	Nickel	150 mm	290 mm	EFX 290
	14,5 mm	10,5 mm	Nickel	370 mm	510 mm	EFX 510
	14,5 mm	10,5 mm	Nickel	150 mm	250 mm	SFX 150
	14,5 mm	10,5 mm	Nickel	370 mm	470 mm	SFX 370
	14,5 mm	10,5 mm	Nickel	500 mm	600 mm	SFX 500
Rim	14,5 mm	10 mm	Grey box Steel flex tube	300 mm	440 mm	BFX 300G
	14,5 mm	10 mm	Grey box Steel flex tube	500 mm	640 mm	BFX 500G
	14,5 mm	10 mm	Brass box Steel flex tube	300 mm	440 mm	BFX 300B
	14,5 mm	10 mm	Brass box Steel flex tube	500 mm	640 mm	BFX 500B
	Round terminals for EFX 290/510					

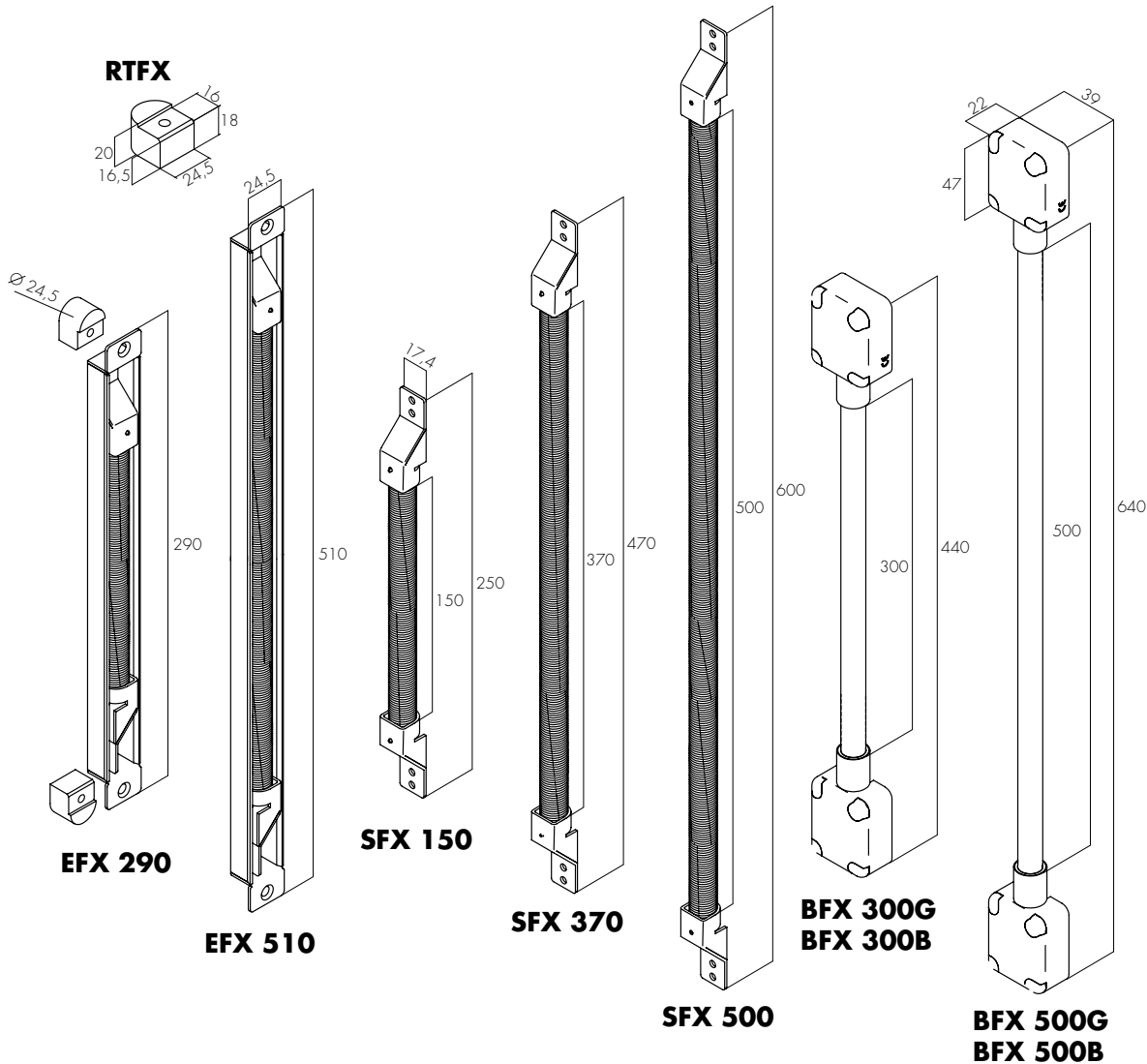

KEYPAD

Series AC

12 button matrix-encoded keypad for **access control of one or two doors**.

OPENERS & CLOSERS Keypad allows to open two doors from only one terminal, and select two opening functions:

- Activates the lock for a preset time.
- Activates the lock until re-entering the code.

Very easy to install with high level of security. During blackouts all the data remain stored.

Technical features

- Anti-vandal.
- Stainless steel buttons
- Housing: grey painted steel
- Timer: 1 to 99 seconds
- Relay: 12V AC - 2A max
- Up to 12 different codes
- Consumption: 0,1A (start-up) 0,02 (stand-by)
- Guaranteed 3 years
- IP45 Certified



AC 100

 Voltage 12V AC/DC

Fastening points

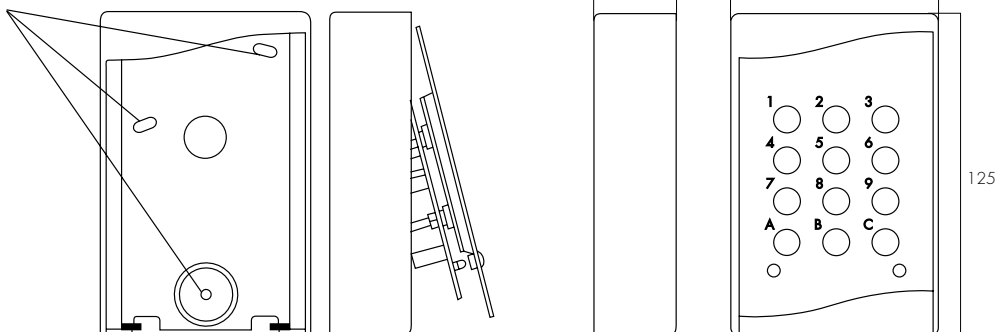

DUMMIES

Series CSR

DUMMY KEEPER

During construction works, it is recommended to install a provisional keeper behind the faceplate that will house the electric strike later, in order to keep the door closed during works and prevent deterioration (or theft) of high-value electric strikes.

Technical features

- Fits all faceplates
- 3mm adjustable

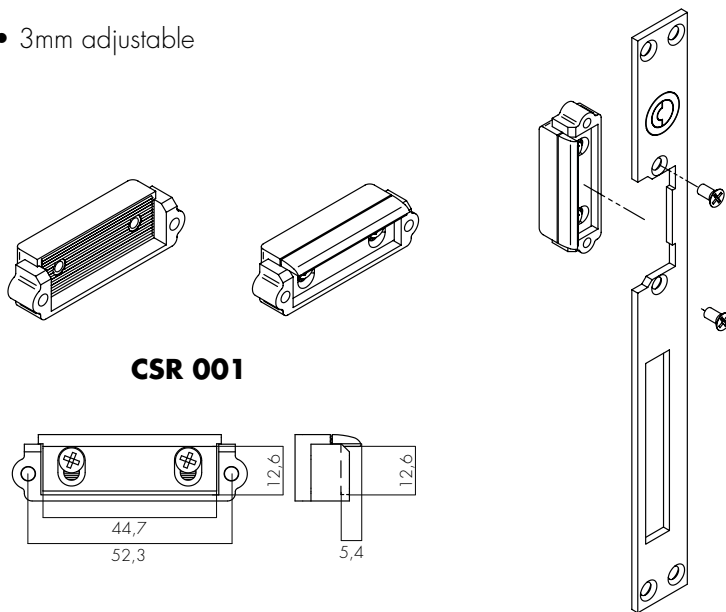

CSR 001

DUMMY STRIKE

This "Mini" door strike without electric function gives the option to mechanically unlock the door when no access control system is installed.

Technical features

- 3mm adjustable
- Radial keeper
- Mechanical unlocking

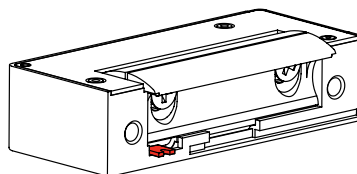

CSR 511



EXIT BUTTONS

Series OC

Our quality stainless steel buttons, mounted next to the door inside the building, **quickly and safely allow door exit** by activating / deactivating the electric locking device.

A LED light around the push button can be useful as guidance in dark environments, while an infrared sensor represents a more hygienic and modern option.



OC 804

Push-Button with LED guidance

Technical features

- Dimensions: 88,6L x 88,6H x 20W (mm)
- Output contact: NO/NC/COM
- Current rating: 3A at 36V DC Max
- Operating temperature: -10 °C / +55 °C
- Suitable Humidity: 0 - 95% (relative humidity)
- Blue LED indicator



OC 806

Infrared Sensor Button

Technical features

- Dimensions: 88,6L x 88,6H x 27W (mm)
- Output contact: NO/NC/COM
- Contact rating: 3A at 28V DC Max
- Operating temperature: -20 °C / +55 °C
- Suitable Humidity: 0 - 95% (relative humidity)
- Detection range: 0,1 - 10 cm
- LED indicator:
 - White: Power off
 - Blue: Power on (standby)
 - Red: Power on (sensation)

POWER SUPPLIES

Series PS

An AC powered unregulated power supply usually uses a transformer to **convert the voltage from the wall outlet** (usually 220V AC) to a lower (usually 12 or 24V AC) voltage.

If it is used to produce DC, a rectifier is used to convert alternating voltage to a pulsating direct voltage (12 or 24V DC).

Our high-efficiency power boxes feature 4 terminals with monitoring leds, a battery charger and a battery backup.

Technical features

- 3% stability
- Protection IP20
- Operating temperature: 0 °C / +40 °C
- Over-heating and short-circuit protection
- Double function: power supply and batteries charging "on line" system, with complete discharge protection.



PS 903

	Input voltage 230 V 50/60Hz	Output voltage	Output current	Power	Battery charge	Battery	Capacity	References
DC current	●	12 V dc	6 A dc	80 W	●			PS 901*
	●	24 V dc	3 A dc	80 W	●			PS 902*
	●	12 V dc	6 A dc	80 W	●	12 V dc	7 Ah	PS 905**
	●	24 V dc	3 A dc	80 W	●	24 V dc	4 Ah	PS 906**
	●	12 V dc	3 A dc	30 W				PS 907*
AC current	●	24 V dc	1,5 A dc	30 W				PS 908*
	●	12 V ac	1,5 A ac	18 VA				PS 903*

* Finish DIN rail 35 x 7,5 (DIN 500 22)

** 4 terminals for 2 magnetic locks each, with monitoring leds.



PS 901 / PS 902



PS 907 / PS 908



PS 905 / PS 906

MAGNETIC CONTACTS

Series CM

	Material	Minimum gap	4 wires	Reed dimensions	Magnet dimensions	Standards Compliance	References
MAGNETIC CONTACTS	Brass	12 mm	●	29,5 x 7,5o mm	27,5 x 7,5o mm	Grade 2 EN50131-2-6	CMI 002
	ABS	12 mm	●	29 x 7,5o mm	29x 7,5o mm	Grade 2 EN50131-2-6	CMI 016
	Brass	20 mm (non iron) 10 mm (iron)	●	18 x 20o mm	18x 20o mm	Grade 2 EN50131-2-6	CMI 130
	ABS	20 mm (non iron) 10 mm (iron)	●	29 x 20o mm	29 x 20o mm	Grade 2 EN50131-2-6	CMI 122
	Plastic	25 - 40 mm	●	56 x 16 x 5 mm	56 x 16 x 5 mm	Grade 2 EN50131-2-6	CME 045
	Polycarbonate	30 mm	●	120 x 40 x 12 mm	77 x 30 x 29 mm	Grade 2 EN50131-2-6	CMB 003
			Reed Features				
				Maximum voltage	200V DC		
				Maximum current	500 mA		
				Maximum power	10VA		
				Initial contact resistance	R=0,1 Ω		
				Insulation resistance	R=10 ¹² Ω		
				Operating temperature	-40 °C / +125 °C		
				MTBF Number of operations	10 ⁸		



CMI 002

Brass magnetic contact designed to guarantee maximum efficiency and duration, particularly suitable for **mortise** mounting on wood and non iron surfaces. Available with 4 output wires, 2 for N.C. contact and 2 for tamper.



CMI 122

Magnetic contact for **mortise** mounting on iron doors. White, resistant ABS housing guarantees duration and reliability. Available with 4 output wires (2 for contact and 2 for tamper), with changeover reed or brown colour.



CMI 016

Magnetic contact for **mortise** mounting, not suitable for iron frames but ideal for installation on aluminium and wood. Also available with output wires, with changeover reed and brown colour.



CME 045

Magnetic contact for **rim** installation on non iron frames and iron frames. Only 5mm thick. A highly sensitive contact guaranteeing a minimum gap of up to 40mm.



CMI 130

This low profile magnetic contact is for **mortise** mounting even on large heavy iron frames. Its finely knurled head can be installed in a 20mm hole maximising the magnetic quality of the contact.



CMB 003

Magnetic contact with highly-resistant black polycarbonate housing for **rim** mounting, suitable for installation on iron frames, garage doors and roller shutters. Contact housing only 12mm thick, with armoured cable.



OPENERS & CLOSERS®
BARCELONA

INNOVATION, QUALITY & SERVICE



GENERAL CATALOGUE
JAN 2012 ISSUE



OPENERS & CLOSERS[®]
Secure locking solutions